

NIRON[®]

Design & Installation Manual 2018



APPROVED FOR POTABLE WATER

PP-RCT Piping Systems

TABLE OF CONTENTS

INTRO

THE COMPANY	4
ACTIVITY	6
WHO WE ARE.....	7

1 PP-RCT PIPING SYSTEM APPLICATIONS

NIRON PP-RCT PIPING SYSTEM	10
NIRON PP-RCT PIPES - PRODUCT RANGE & APPLICATIONS	11
DIMENSIONAL DATA FOR NIRON CLIMA AND FG RED PIPE	12
DIMENSIONAL DATA FOR NIRON BLUE AND MONO GREY PIPE.....	14
NIRON PP-RCT PIPE	16
NIRON WITH FIBERGLASS	24
WATER RECYCLING SYSTEMS.....	26
DISTRIBUTION MANIFOLDS	28
PREINSULATED PIPE	30
UV RAY PROTECTION PIPE.....	32

2 TECHNICAL CHARACTERISTICS

2.1 BENEFITS	37
2.1.1 POLYPROPYLENE	37
2.1.2 PROPERTIES OF THE MATERIAL (PP-RCT)	38
2.1.3 CERTIFIED QUALITY	39
2.1.4 CONTROL SYSTEM	40
2.1.5 QUALITY ASSURANCE.....	40
2.2 PRESSURE RATINGS FOR NIRON PP-RCT PIPE	43
2.3 HOOP STRESS DATA FOR NIRON PP-RCT PIPE	45

3 WELDING SYSTEMS

3.1 WELDING EQUIPMENT	48
3.2 SOCKET FUSION WELDING.....	51
3.2.1 WARNINGS AND PRELIMINARY RECOMMENDATIONS	51
3.2.2 SOCKET FUSION WELDING: FITTINGS	52
3.2.3 SOCKET FUSION WELDING: INSTABRANCH™ FITTING.....	55
3.2.4 POLYFUSION WELDING: REPAIR OF A PIPE DAMAGE BY NAIL OF SCREWS	57
3.3 ELECTROFUSION WELDING PROCEDURE.....	59
3.4 BUTT FUSION WELDING	63
3.4.1 INTRODUCTION	63
3.4.2 RECOMMENDATIONS AND WARNINGS.....	63
3.4.3 BUTT FUSION WELDING PROCEDURE.....	64
3.4.4 BUTT FUSION WELDING PARAMETERS.....	68

TABLE OF CONTENTS

4	TECHNICAL DATA	
4.1	CHEMICAL, PHYSICAL AND MECHANICAL PROPERTIES OF PP-RCT	72
4.2	THE PIPE	72
4.3	THERMAL EXPANSION	73
4.3.1	USE OF THERMAL EXPANSION ALLEVIATION METHODS (UNI EN 806-4)	76
4.3.2	ABOVE GROUND SUPPORT OF NIRON PIPES	79
4.3.3	SUPPORT SPACING FOR NIRON PP-RCT PIPE	80
4.4	HEAT LOSS	82
4.5	MIN INSULATION TO PREVENT SWEATING IN AIR CONDITIONING SYSTEMS	83
4.6	VELOCITY, HEAD LOSS AND PRESSURE DROP	87
4.7	FITTING EQUIVALENT LENGTHS	137
4.8	SYSTEM TESTING	142
4.9	CHEMICAL COMPATIBILITY OF NIRON PP-RCT	143





Nupi - Registered Office/Headquarters and Production Facility - Busto Arsizio (VA)



Nupi - Production Facility - Castel Guelfo di Bologna (BO)



Nupi - Production Facility - Imola (BO)

Nupi Americas' parent company, **Nupi Industrie Italiane, S.p.A.**, was formed in Italy more than 40 years ago in the early 1970's.

Relying on experience and constant growth, our company has proven to be a flexible, cutting edge manufacturer, ready to meet the needs of the market while also protecting the environment. In 2001, **Nupi Industrie Italiane, S.p.A.** entered the North American market by establishing **Nupi Americas, Inc.**, a wholly-owned subsidiary of Nupi Industrie Italiane, with operations based in Houston, TX and Early Branch, South Carolina.

NUPI Industrie Italiane, S.p.A. and **Nupi Americas** together develop and manufacture piping systems for use in industrial, sanitary (plumbing), HVAC, waterworks, gas, and irrigation markets. **Nupi's** Industrial division was established in 1995 to develop and produce thermoplastic piping systems specifically targeted to the oil and gas, chemical and petrochemical markets. These products are distributed worldwide in more than 70 countries.

NUPI Industrie Italiane, S.p.A. offers a complete range of pipes and fittings made in advanced thermoplastic materials with trademarks **NIRON, MULTINUPI, ELOFIT, ELOTHERM, ELOPRESS, POLYSYSTEM, POLYETHYLENE PIPES, MULTIGECO, SMARTFLEX, OILTECH, SUPER OILTECH, ELOWEB, ECOWAVE, NRGeo and others.** These trademarked systems are real "system solutions", covering a wide range of applications, reducing costs, avoiding waste and increasing productivity. The products have obtained the most prestigious certificates and listings, in line with the regulations of the five continents for the construction of water and gas networks and systems for the transport of fuel.

Producing better quality and being cost effective is the goal, which is made easier everyday by new technology. **Nupi Industrie Italiane, S.p.A.** is continuously investing in research and development programs, while



THE COMPANY

strengthening our production systems, operated by a sophisticated technology that guarantees the highest quality of products. Our facilities use modern, state-of-the-art computer-controlled production equipment and methods, which together with continuous quality control systems guarantees products of the highest quality. On these solid foundations the company demonstrates leadership throughout the thermoplastic piping industry.

Our customers can rely on the best quality materials and precision manufacturing, obtained through completely automated production systems and continuous on-time deliveries, resulting in timely deliveries which allow planning to be done in real time. Customer satisfaction is pursued through high quality products and the constant attention to our customer's needs and requirements, and by means of an effective team of people in post-sales service, effective and precise technical assistance, and intensive training of installers.

The world headquarters and injection molding operations of **NUPI Industrie Italiane, S.p.A.** are located in Busto Arsizio near Milan, Italy. Major extrusion facilities and support operations are located in Castel Guelfo (Bo) and Imola (Bo) situated in strategic industrial areas near Bologna. The company is present all over the world, with operations in North America (**Nupi Americas**), Brazil, China, Australia, UAE, Germany, France, Spain, Belgium and the UK.



Nupi - Distribution & Fabrication Facility Early Branch, SC



Highly advanced in the transportation of industrial liquids and gases with engineering thermoplastic piping systems

Irrigation
Waterworks
Gas
Heating
Sanitary
Fluid Transport
Food
Air Conditioning
Cooling Equipment
Petroleum
Chemical
Petrochemical



Our numbers

- Established for over 40 years
- 22 product lines
- Multiple Manufacturing Facilities on Several Continents
- North American Production Facilities in South Carolina, and Houston
- 35 total extrusion lines worldwide
- 40 injection molding machines for the production of fittings
- North American Warehouse facilities in South Carolina and Houston.
- Heavy investment in research & development
- Over 1,500,000 square feet of surface area occupied by our worldwide locations

Our strengths

- Exports established in more than 70 countries in 5 continents
- Worldwide after-sales assistance
- R & D department dedicated to Internal Development, Technical Support, After-Sales Service
- Production of pipes and fittings from 1/2 inch to 40 inch
- Training Centers Located throughout North America and worldwide

NIRON[®]

PP-RCT PIPING

SYSTEMS

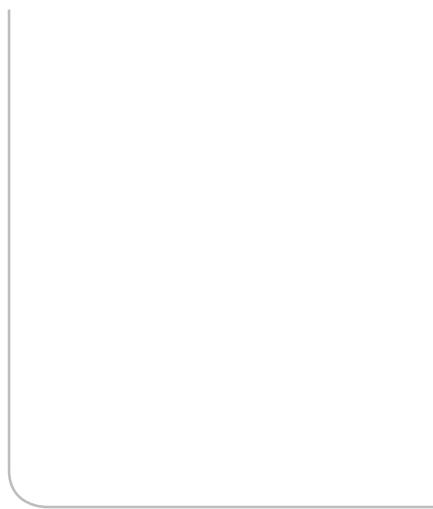



PP-RCT PIPING SYSTEMS APPLICATIONS



NIRON PP-RCT PIPING SYSTEMS

The advanced beta crystalline PP-RCT Polypropylene in Niron allows for a wide range of every day and technically-challenging applications to be handled.

Niron's state-of-the-art PP-RCT materials are not limited to sanitary applications (e.g. potable water, and HVAC applications), as the exceptionally strong and stable beta-crystalline matrix of the polymer allows for its use in the harshest conditions. New coextrusion technologies together with the advanced resin allow for Niron to be used in extremely difficult conditions including:









- 1) water that is sanitized beyond normal means using harsh reagents such as free chlorine and chloramines;
- 2) applications involving harsh chemical substances added to water, e.g. in cooling towers where new generation biocide agents with a high concentration of free chlorine are used (a major enemy of most traditional materials, including standard PPR);
- 3) increased operating pressures, especially at elevated temperatures;
- 4) applications with exceptionally high flow rates and velocities (especially in air-conditioning systems of large buildings).

Niron is available in pipe sizes up to 40 inch in monolayer pipes and up to 24 inch for Niron FR systems (pipe which is manufactured with fiberglass layers to limit thermal expansion and contraction).

Niron is available in a variety of pressure classes to allow for the widest possible range of applications, in both monolayer types, as well as in Niron FR piping. Niron is also extruded with a wide variety of optional internal and external linings to provide protection against oxidation due to sunlight, internal or external chemical attack, or to add fire resistance.

PP-RCT PIPES - PRODUCT RANGE & APPLICATIONS

	RANGE NAME	PRODUCT NAME	PRODUCT IDENTIFICATION COLOR	COMPOSITION	SDR	from size	to size
●	NIRON	MONO BLUE	GREY + BLUE STRIPES	100% PP-RCT	7.3	½"	¾"
●	NIRON	MONO BLUE	GREY + BLUE STRIPES	100% PP-RCT	9	1"	1"
●	NIRON	MONO BLUE	GREY + BLUE STRIPES	100% PP-RCT	11	1¼"	6"
●	NIRON	MONO BLUE	GREY + BLUE STRIPES	100% PP-RCT	17	2"	6"
●	NIRON	MONO GREY	GREY	100% PP-RCT	7.3	½"	¾"
●	NIRON	MONO GREY	GREY	100% PP-RCT	9	1"	1"
●	NIRON	MONO GREY	GREY	100% PP-RCT	11	1¼"	24"
●	NIRON	MONO GREY	GREY	100% PP-RCT	17	2"	24"
●	NIRON	MULTI FG RED	GREY + RED STRIPES	PP-RCT + FG FILLED LAYER	7.3	½"	6"
●	NIRON	MULTI FG RED	GREY + RED STRIPES	PP-RCT + FG FILLED LAYER	9	1"	6"
●	NIRON	MULTI FG RED	GREY + RED STRIPES	PP-RCT + FG FILLED LAYER	11	1¼"	6"
●	NIRON	CLIMA	GREY	PP-RCT + FG FILLED LAYER	7.3	½"	14"
●	NIRON	CLIMA	GREY	PP-RCT + FG FILLED LAYER	9	1"	6"
●	NIRON	CLIMA	GREY	PP-RCT + FG FILLED LAYER	11	1¼"	16"
●	NIRON	CLIMA	GREY	PP-RCT + FG FILLED LAYER	17	2"	24"
●	NIRON	NERO BY NIRON 11	GREY + BLACK EXTERIOR	PP-RCT + FG LAYER + PPR	11	1"	16"
●	NIRON	NERO BY NIRON 17	GREY + BLACK EXTERIOR	PP-RCT + FG LAYER + PPR	17	2"	16"
●	NIRON	PURPLE	PURPLE	PP-RCT + PURPLE LAYER	7.3	½"	¾"
●	NIRON	PURPLE	PURPLE	PP-RCT + PURPLE LAYER	9	1"	1"
●	NIRON	PURPLE	PURPLE	PP-RCT + PURPLE LAYER	11	1¼"	1½"
●	NIRON	PURPLE	PURPLE	PP-RCT + PURPLE LAYER	17	2"	10"

	HVACR							
Drinking water		Swimming pools	Chemical fluids	Recycled water	Compressed air	Heating	Geothermal applications	Ship building industry
●								●
●								●
●	●	●	●		●		●	●
●	●	●	●		●	●	●	●
	●		●			●	●	●
				●				



DIMENSIONAL DATA FOR NIRON CLIMA AND FG RED PIPE

Nominal Diam.	Actual Outside Diam. inches	Actual Outside Diam. mm	SDR	Wall inches	Inside Diam.	Cross Sect. Area Pipe in ²	Transverse Area in ²	Transverse Area ft ²	Weight of Empty Pipe lbs/ft	Weight of H ₂ O lbs/ft	Weight of Pipe with H ₂ O lbs/ft	Moment of Inertia in ⁴	Section Modulus in ³	External Surface Area ft ² /ft
½	0.79	20	7.3	0.11	0.57	0.2304	0.2568	0.00178	0.10	0.11	0.21	0.01363	0.03463	0.206
	0.98	25	7.3	0.13	0.71	0.3599	0.4012	0.00279	0.15	0.17	0.33	0.03328	0.06763	0.258
1	1.26	32	7.3	0.17	0.91	0.5897	0.6574	0.00456	0.25	0.28	0.54	0.08934	0.14182	0.330
	1.26	32	9	0.14	0.98	0.4927	0.7544	0.00524	0.21	0.33	0.54	0.07844	0.12452	0.330
1¼	1.57	40	7.3	0.22	1.14	0.9215	1.0271	0.00713	0.39	0.45	0.84	0.21811	0.27700	0.412
	1.57	40	9	0.17	1.22	0.7698	1.1788	0.00819	0.33	0.51	0.84	0.19150	0.24321	0.412
	1.57	40	11	0.14	1.29	0.6442	1.3044	0.00906	0.28	0.57	0.84	0.16668	0.21169	0.412
	1.57	40	17	0.09	1.39	0.4315	1.5171	0.01054	0.18	0.66	0.84	0.11896	0.15108	0.412
1½	1.97	50	7.3	0.27	1.43	1.4398	1.6049	0.01115	0.62	0.70	1.31	0.53250	0.54102	0.516
	1.97	50	9	0.22	1.53	1.2028	1.8418	0.01279	0.51	0.80	1.31	0.46753	0.47501	0.516
	1.97	50	11	0.18	1.61	1.0065	2.0382	0.01415	0.43	0.88	1.31	0.40694	0.41345	0.516
	1.97	50	17	0.12	1.74	0.6742	2.3704	0.01646	0.29	1.03	1.32	0.29043	0.29507	0.516
2	2.48	63	7.3	0.34	1.80	2.2858	2.5479	0.01769	0.98	1.10	2.08	1.34214	1.08224	0.650
	2.48	63	9	0.28	1.93	1.9096	2.9241	0.02031	0.82	1.27	2.08	1.17841	0.95021	0.650
	2.48	63	11	0.23	2.03	1.5979	3.2358	0.02247	0.68	1.40	2.09	1.02568	0.82706	0.650
	2.48	63	17	0.15	2.19	1.0704	3.7632	0.02613	0.46	1.63	2.09	0.73201	0.59026	0.650
2½	2.95	75	7.3	0.40	2.14	3.2395	3.6110	0.02508	1.39	1.56	2.95	2.69576	1.82593	0.773
	2.95	75	9	0.33	2.30	2.7064	4.1441	0.02878	1.16	1.80	2.95	2.36689	1.60317	0.773
	2.95	75	11	0.27	2.42	2.2646	4.5858	0.03185	0.97	1.99	2.96	2.06013	1.39540	0.773
	2.95	75	17	0.17	2.61	1.5171	5.3334	0.03704	0.65	2.31	2.96	1.47029	0.99587	0.773
3	3.54	90	7.3	0.49	2.57	4.6648	5.1998	0.03611	2.00	2.25	4.25	5.58993	3.15521	0.928
	3.54	90	9	0.39	2.76	3.8972	5.9675	0.04144	1.67	2.59	4.25	4.90798	2.77028	0.928
	3.54	90	11	0.32	2.90	3.2610	6.6036	0.04586	1.40	2.86	4.26	4.27189	2.41125	0.928
	3.54	90	17	0.21	3.13	2.1846	7.6801	0.05333	0.93	3.33	4.26	3.04879	1.72087	0.928
4	4.33	110	7.3	0.59	3.14	6.9685	7.7676	0.05394	2.98	3.37	6.35	12.47	5.76	1.134
	4.33	110	9	0.48	3.37	5.8217	8.9144	0.06191	2.49	3.86	6.35	10.95	5.06	1.134
	4.33	110	11	0.39	3.54	4.8714	9.8647	0.06850	2.08	4.27	6.36	9.53	4.40	1.134
	4.33	110	17	0.25	3.82	3.2634	11.4727	0.07967	1.40	4.97	6.37	6.80	3.14	1.134
5	4.92	125	7.3	0.67	3.57	8.9985	10.0305	0.06966	3.85	4.35	8.20	20.80	8.45	1.289
	4.92	125	9	0.55	3.83	7.5177	11.5114	0.07994	3.22	4.99	8.20	18.26	7.42	1.289
	4.92	125	11	0.45	4.03	6.2906	12.7385	0.08846	2.69	5.52	8.21	15.90	6.46	1.289
	4.92	125	17	0.29	4.34	4.2140	14.8150	0.10288	1.80	6.42	8.22	11.34	4.61	1.289

DIMENSIONAL DATA FOR NIRON CLIMA AND FG RED PIPE

Nominal Diam.	Actual Outside Diam. inches	Actual Outside Diam. mm	SDR	Wall inches	Inside Diam.	Cross Sect. Area Pipe in ²	Transverse Area in ²	Transverse Area ft ²	Weight of Empty Pipe lbs/ft	Weight of H ₂ O lbs/ft	Weight of Pipe with H ₂ O lbs/ft	Moment of Inertia in ⁴	Section Modulus in ³	External Surface Area ft ² /ft
6	6.30	160	7.3	0.86	4.57	14.7432	16.4340	0.11412	6.31	7.12	13.43	55.84	17.73	1.650
	6.30	160	9	0.70	4.90	12.3169	18.8603	0.13097	5.27	8.17	13.44	49.02	15.57	1.650
	6.30	160	11	0.57	5.15	10.3065	20.8707	0.14494	4.41	9.04	13.45	42.67	13.55	1.650
	6.30	160	17	0.37	5.56	6.9043	24.2729	0.16856	2.95	10.52	13.47	30.45	9.67	1.650
8	7.87	200	7.3	1.08	5.72	23.0363	25.6781	0.17832	9.86	11.13	20.98	136.3	34.6	2.062
	7.87	200	9	0.87	6.12	19.2452	29.4692	0.20465	8.23	12.77	21.00	119.7	30.4	2.062
	7.87	200	11	0.72	6.44	16.1039	32.6105	0.22646	6.89	14.13	21.02	104.2	26.5	2.062
	7.87	200	17	0.46	6.95	10.7880	37.9264	0.26338	4.62	16.43	21.05	74.3	18.9	2.062
10	9.84	250	7.3	1.35	7.15	35.9942	40.1221	0.27863	15.40	17.39	32.78	332.8	67.6	2.578
	9.84	250	9	1.09	7.66	30.0706	46.0456	0.31976	12.86	19.95	32.82	292.2	59.4	2.578
	9.84	250	11	0.89	8.05	25.1624	50.9538	0.35385	10.76	22.08	32.84	254.3	51.7	2.578
	9.84	250	17	0.58	8.68	16.8562	59.2600	0.41153	7.21	25.68	32.89	181.5	36.9	2.578
12	12.40	315	7.3	1.70	9.00	57.1443	63.6978	0.44235	24.45	27.60	52.05	838.8	135.3	3.248
	12.40	315	9	1.38	9.65	47.7401	73.1020	0.50765	20.42	31.68	52.10	736.5	118.8	3.248
	12.40	315	11	1.13	10.15	39.9478	80.8943	0.56177	17.09	35.05	52.14	641.1	103.4	3.248
	12.40	315	17	0.73	10.94	26.7609	94.0812	0.65334	11.45	40.77	52.22	457.5	73.8	3.248
14	13.98	355	7.3	1.91	10.15	72.5786	80.9021	0.56182	31.05	35.06	66.11	1353.2	193.6	3.660
	13.98	355	9	1.55	10.87	60.6344	92.8464	0.64477	25.94	40.23	66.17	1188.1	170.0	3.660
	13.98	355	11	1.27	11.44	50.7374	102.7433	0.71350	21.71	44.52	66.23	1034.1	148.0	3.660
	13.98	355	17	0.82	12.33	33.9888	119.4919	0.82981	14.54	51.78	66.32	738.0	105.6	3.660
16	15.75	400	9	1.75	12.25	76.9808	117.8768	0.81859	32.93	51.08	84.01	1915.0	243.2	4.124
	15.75	400	11	1.43	12.88	64.4157	130.4418	0.90585	27.56	56.52	84.08	1666.8	211.7	4.124
	15.75	400	17	0.93	13.90	43.1518	151.7057	1.05351	18.46	65.74	84.20	1189.6	151.1	4.124
18	17.72	450	11	1.61	14.50	81.5261	165.0904	1.14646	34.88	71.54	106.42	2669.9	301.4	4.640
	17.72	450	17	1.04	15.63	54.6140	192.0025	1.33335	23.36	83.20	106.57	1905.5	215.1	4.640
20	19.69	500	11	1.79	16.11	100.6496	203.8153	1.41538	43.06	88.32	131.38	4069.4	413.5	5.156
	19.69	500	17	1.16	17.37	67.4248	237.0401	1.64611	28.84	102.72	131.56	2904.3	295.1	5.156
22	22.05	560	11	2.00	18.04	126.2548	255.6660	1.77546	54.01	110.79	164.80	6403.3	580.9	5.774
	22.05	560	17	1.30	19.45	84.5776	297.3432	2.06488	36.18	128.85	165.03	4569.9	414.6	5.774
24	24.80	630	17	1.46	21.89	107.0435	376.3249	2.61337	45.79	163.07	208.87	7320.1	590.3	6.496



DIMENSIONAL DATA FOR NIRON BLUE AND MONO GREY PIPE

Nominal Diam.	Actual Outside Diam. inches	Actual Outside Diam. mm	SDR	Wall inches	Inside Diam.	Cross Sect. Area Pipe in ²	Transverse Area in ²	Transverse Area ft ²	Weight of Empty Pipe lbs/ft	Weight of H ₂ O lbs/ft	Weight of Pipe with H ₂ O lbs/ft	Moment of Inertia in ⁴	Section Modulus in ³	External Surface Area ft ² /ft
½	0.79	20	7.3	0.11	0.57	0.2304	0.2568	0.00178	0.09	0.11	0.20	0.01363	0.03463	0.206
	0.98	25	7.3	0.13	0.71	0.3599	0.4012	0.00279	0.14	0.17	0.32	0.03328	0.06763	0.258
1	1.26	32	7.3	0.17	0.91	0.5897	0.6574	0.00456	0.23	0.28	0.52	0.08934	0.14182	0.330
	1.26	32	9	0.14	0.98	0.4927	0.7544	0.00524	0.19	0.33	0.52	0.07844	0.12452	0.330
1¼	1.57	40	7.3	0.22	1.14	0.9215	1.0271	0.00713	0.36	0.45	0.81	0.21811	0.27700	0.412
	1.57	40	9	0.17	1.22	0.7698	1.1788	0.00819	0.30	0.51	0.81	0.19150	0.24321	0.412
	1.57	40	11	0.14	1.29	0.6442	1.3044	0.00906	0.25	0.57	0.82	0.16668	0.21169	0.412
	1.57	40	17	0.09	1.39	0.4315	1.5171	0.01054	0.17	0.66	0.83	0.11896	0.15108	0.412
1½	1.97	50	7.3	0.27	1.43	1.4398	1.6049	0.01115	0.56	0.70	1.26	0.53250	0.54102	0.516
	1.97	50	9	0.22	1.53	1.2028	1.8418	0.01279	0.47	0.80	1.27	0.46753	0.47501	0.516
	1.97	50	11	0.18	1.61	1.0065	2.0382	0.01415	0.39	0.88	1.28	0.40694	0.41345	0.516
	1.97	50	17	0.12	1.74	0.6742	2.3704	0.01646	0.26	1.03	1.29	0.29043	0.29507	0.516
2	2.48	63	7.3	0.34	1.80	2.2858	2.5479	0.01769	0.90	1.10	2.00	1.34214	1.08224	0.650
	2.48	63	9	0.28	1.93	1.9096	2.9241	0.02031	0.75	1.27	2.02	1.17841	0.95021	0.650
	2.48	63	11	0.23	2.03	1.5979	3.2358	0.02247	0.63	1.40	2.03	1.02568	0.82706	0.650
	2.48	63	17	0.15	2.19	1.0704	3.7632	0.02613	0.42	1.63	2.05	0.73201	0.59026	0.650
2½	2.95	75	7.3	0.40	2.14	3.2395	3.6110	0.02508	1.27	1.56	2.84	2.69576	1.82593	0.773
	2.95	75	9	0.33	2.30	2.7064	4.1441	0.02878	1.06	1.80	2.86	2.36689	1.60317	0.773
	2.95	75	11	0.27	2.42	2.2646	4.5858	0.03185	0.89	1.99	2.88	2.06013	1.39540	0.773
	2.95	75	17	0.17	2.61	1.5171	5.3334	0.03704	0.59	2.31	2.91	1.47029	0.99587	0.773
3	3.54	90	7.3	0.49	2.57	4.6648	5.1998	0.03611	1.83	2.25	4.08	5.58993	3.15521	0.928
	3.54	90	9	0.39	2.76	3.8972	5.9675	0.04144	1.53	2.59	4.11	4.90798	2.77028	0.928
	3.54	90	11	0.32	2.90	3.2610	6.6036	0.04586	1.28	2.86	4.14	4.27189	2.41125	0.928
	3.54	90	17	0.21	3.13	2.1846	7.6801	0.05333	0.86	3.33	4.18	3.04879	1.72087	0.928
4	4.33	110	7.3	0.59	3.14	6.9685	7.7676	0.05394	2.73	3.37	6.10	12.47	5.76	1.134
	4.33	110	9	0.48	3.37	5.8217	8.9144	0.06191	2.28	3.86	6.15	10.95	5.06	1.134
	4.33	110	11	0.39	3.54	4.8714	9.8647	0.06850	1.91	4.27	6.19	9.53	4.40	1.134
	4.33	110	17	0.25	3.82	3.2634	11.4727	0.07967	1.28	4.97	6.25	6.80	3.14	1.134
5	4.92	125	7.3	0.67	3.57	8.9985	10.0305	0.06966	3.53	4.35	7.88	20.80	8.45	1.289
	4.92	125	9	0.55	3.83	7.5177	11.5114	0.07994	2.95	4.99	7.94	18.26	7.42	1.289
	4.92	125	11	0.45	4.03	6.2906	12.7385	0.08846	2.47	5.52	7.99	15.90	6.46	1.289
	4.92	125	17	0.29	4.34	4.2140	14.8150	0.10288	1.65	6.42	8.07	11.34	4.61	1.289

DIMENSIONAL DATA FOR NIRON BLUE AND MONO GREY PIPE

Nominal Diam.	Actual Outside Diam. inches	Actual Outside Diam. mm	SDR	Wall inches	Inside Diam.	Cross Sect. Area Pipe in ²	Transverse Area in ²	Transverse Area ft ²	Weight of Empty Pipe lbs/ft	Weight of H ₂ O lbs/ft	Weight of Pipe with H ₂ O lbs/ft	Moment of Inertia in ⁴	Section Modulus in ³	External Surface Area ft ² /ft
6	6.30	160	7.3	0.86	4.57	14.7432	16.4340	0.11412	5.78	7.12	12.90	55.84	17.73	1.650
	6.30	160	9	0.70	4.90	12.3169	18.8603	0.13097	4.83	8.17	13.00	49.02	15.57	1.650
	6.30	160	11	0.57	5.15	10.3065	20.8707	0.14494	4.04	9.04	13.09	42.67	13.55	1.650
	6.30	160	17	0.37	5.56	6.9043	24.2729	0.16856	2.71	10.52	13.23	30.45	9.67	1.650
8	7.87	200	7.3	1.08	5.72	23.0363	25.6781	0.17832	9.03	11.13	20.16	136.3	34.6	2.062
	7.87	200	9	0.87	6.12	19.2452	29.4692	0.20465	7.55	12.77	20.32	119.7	30.4	2.062
	7.87	200	11	0.72	6.44	16.1039	32.6105	0.22646	6.32	14.13	20.45	104.2	26.5	2.062
	7.87	200	17	0.46	6.95	10.7880	37.9264	0.26338	4.23	16.43	20.67	74.3	18.9	2.062
10	9.84	250	7.3	1.35	7.15	35.9942	40.1221	0.27863	14.12	17.39	31.50	332.8	67.6	2.578
	9.84	250	9	1.09	7.66	30.0706	46.0456	0.31976	11.79	19.95	31.75	292.2	59.4	2.578
	9.84	250	11	0.89	8.05	25.1624	50.9538	0.35385	9.87	22.08	31.95	254.3	51.7	2.578
	9.84	250	17	0.58	8.68	16.8562	59.2600	0.41153	6.61	25.68	32.29	181.5	36.9	2.578
12	12.40	315	7.3	1.70	9.00	57.1443	63.6978	0.44235	22.41	27.60	50.01	838.8	135.3	3.248
	12.40	315	9	1.38	9.65	47.7401	73.1020	0.50765	18.72	31.68	50.40	736.5	118.8	3.248
	12.40	315	11	1.13	10.15	39.9478	80.8943	0.56177	15.67	35.05	50.72	641.1	103.4	3.248
	12.40	315	17	0.73	10.94	26.7609	94.0812	0.65334	10.49	40.77	51.26	457.5	73.8	3.248
14	13.98	355	7.3	1.91	10.15	72.5786	80.9021	0.56182	28.46	35.06	63.52	1353.2	193.6	3.660
	13.98	355	9	1.55	10.87	60.6344	92.8464	0.64477	23.78	40.23	64.01	1188.1	170.0	3.660
	13.98	355	11	1.27	11.44	50.7374	102.7433	0.71350	19.90	44.52	64.42	1034.1	148.0	3.660
	13.98	355	17	0.82	12.33	33.9888	119.4919	0.82981	13.33	51.78	65.11	738.0	105.6	3.660
16	15.75	400	9	1.75	12.25	76.9808	117.8768	0.81859	30.19	51.08	81.27	1915.0	243.2	4.124
	15.75	400	11	1.43	12.88	64.4157	130.4418	0.90585	25.26	56.52	81.79	1666.8	211.7	4.124
	15.75	400	17	0.93	13.90	43.1518	151.7057	1.05351	16.92	65.74	82.66	1189.6	151.1	4.124
18	17.72	450	11	1.61	14.50	81.5261	165.0904	1.14646	31.97	71.54	103.51	2669.9	301.4	4.640
	17.72	450	17	1.04	15.63	54.6140	192.0025	1.33335	21.42	83.20	104.62	1905.5	215.1	4.640
20	19.69	500	11	1.79	16.11	100.6496	203.8153	1.41538	39.47	88.32	127.79	4069.4	413.5	5.156
	19.69	500	17	1.16	17.37	67.4248	237.0401	1.64611	26.44	102.72	129.16	2904.3	295.1	5.156
22	22.05	560	11	2.00	18.04	126.2548	255.6660	1.77546	49.51	110.79	160.30	6403.3	580.9	5.774
	22.05	560	17	1.30	19.45	84.5776	297.3432	2.06488	33.17	128.85	162.02	4569.9	414.6	5.774
24	24.80	630	17	1.46	21.89	107.0435	376.3249	2.61337	41.98	163.07	205.05	7320.1	590.3	6.496

NIRON® PP-RCT PIPE

NIRON PP-RCT PIPE

NIRON is the tradename for Nupi America's thermoplastic piping systems which are manufactured from advanced beta-crystalline Polypropylene Random Copolymer (PP-RCT).

The systems are available in a wide variety of configurations, identified through colored coatings, colored stripes and other markings to identify their class of service.

NIRON PP-RCT PIPING SYSTEMS allow the transport of hot and cold fluids for a variety of services in commercial, residential, food, health, institutional, industrial, and chemical markets.

The systems can be used in a very wide variety of systems involving many different kinds of aggressive fluids and services. The systems are excellent in hot and cold services alike, from applications as diverse as hot geothermal/hydronic distribution piping to chilled water applications in air conditioning systems

The types of buildings and structures in which Niron PP-RCT piping can be applied are widely varied and include large residential units, hotels, dormitories, hospitals, office buildings, shopping malls, churches, schools, gyms, and ocean vessels.

Produced since 1982, more than 200,000 miles of Niron piping and related fittings have been installed on 5 continents to the complete satisfaction of installers and end users.





Drinking water distribution networks

Niron PP-RCT piping systems can be used in the transport of hot and cold drinking water.



Systems for central thermal regulation

Installations in large civil and industrial buildings for commercial or residential use that require the vertical distribution of piping for the transport of the fluid.



Air handling units and rooftop units

Niron is ideal for the transport and distribution of cooling water, chilled water and glycol solutions, including rooftop installations. Niron is not only a cost effective material to install but it also is energy efficient and can reduce or eliminate insulation needs.



Chilled water is used to cool the air in a building and the equipment for refrigeration units, especially when many individual rooms must be separately controlled (e.g. a hotel).

Chilled water is produced by an individual unit sized according to the dimensions of the room to serve. The advantage provided by the size of the refrigeration unit is based on the principles of economy of scale.

As a consequence, the greater the size of the refrigeration unit, the lower its power consumption. According to these considerations, it is necessary to rely on an energy efficient material, such as our Niron PP-RCT pipe and fitting system. Niron PP-RCT piping systems can provide saving requirements in terms of: reduced piping insulation, lower heat transmission, quicker installation times and reduced head loss.

Thanks to the Niron PP-RCT piping systems, commercial buildings can lower total installed costs for the piping portions of these systems 20% or more.



VERSATILE HORIZONTAL AND VERTICAL INSTALLATIONS



RISERS

Hot and cold water distribution networks made of vertical risers in the following configurations:

- water distribution from the public water supply;
- branching patterns;
- horizontal ring patterns;
- cage patterns.

TERMINATING COLLECTION POINTS





COOLING TOWERS: Big office and commercial buildings, hospitals, schools and shopping malls typically use one or more cooling towers as part of their air conditioning systems, especially in Southern climates. Industrial cooling towers are used to remove the heat of the production process. The main aim of large industrial cooling towers is to eliminate the heat absorbed by the circulating systems for cooling water.



MECHANICAL ROOMS

Niron PP-RCT Piping systems are ideal for use in mechanical rooms and are ideally paired with many types of pumps including centrifugal pumps, multi-stage pumps, wet rotor pumps, impellers, magnet dynamic fluid pumps, axial pumps, hydraulic water hammer pumps, linear dynamic fluid pumps.





PP-RCT PIPING SYSTEMS FOR THE PRESSURIZED TRANSPORT OF WATER AND AGGRESSIVE FLUIDS

Mining industry
Iron and Steel industry
Plating industry
Chemical industry
Pharmaceutical industry
Defense industry

Heavy Manufacturing
Aircraft industry
Automotive industry
Military Applications
Petrochemical industry
Ship building industry

Textile industry
Pulp and Paper
Food and Beverage industry
Microelectronics industry
Livestock industry
Construction Material industry



MARINE VESSELS Niron PPR piping has been installed on a range of ocean vessels such as passenger ships, motor-boats, cruise ships, ferries, oil tankers, merchant ships, container ships, military vessels and luxury yachts.

NIRON® FG Red NIRON® Clima

NIRON WITH FIBERGLASS

Niron FG Red and Niron Clima PP-RCT multilayer pipes are coextruded with a layer of material that contains glass fibers that have been added to achieve dimensional stability (reduced thermal expansion).

These coextruded pipes are visually identifiable by means of a subtle difference in the color of the layers. The pipes are composed of several layers: the inner and outer are beta crystalline PP-RCT; the intermediate is the same beta-crystalline PP-RCT loaded with a preset percentage of fiberglass. The color of the middle layer is slightly different than the inner and outer layers and is typically a lighter color.

The layer with added fiberglass restricts growth due to temperature changes. The main effect of the glass fiber reinforcement is that it reduces thermal expansion and contraction in the polypropylene to a value that is similar to that of copper piping. It also provides additional stiffening to the pipe which helps with support spacing.

The three layers are made of relatively equal thicknesses and are available in straight lengths. Nupi Americas also offers monolayer NIRON PP-RCT piping for applications with constant temperatures.



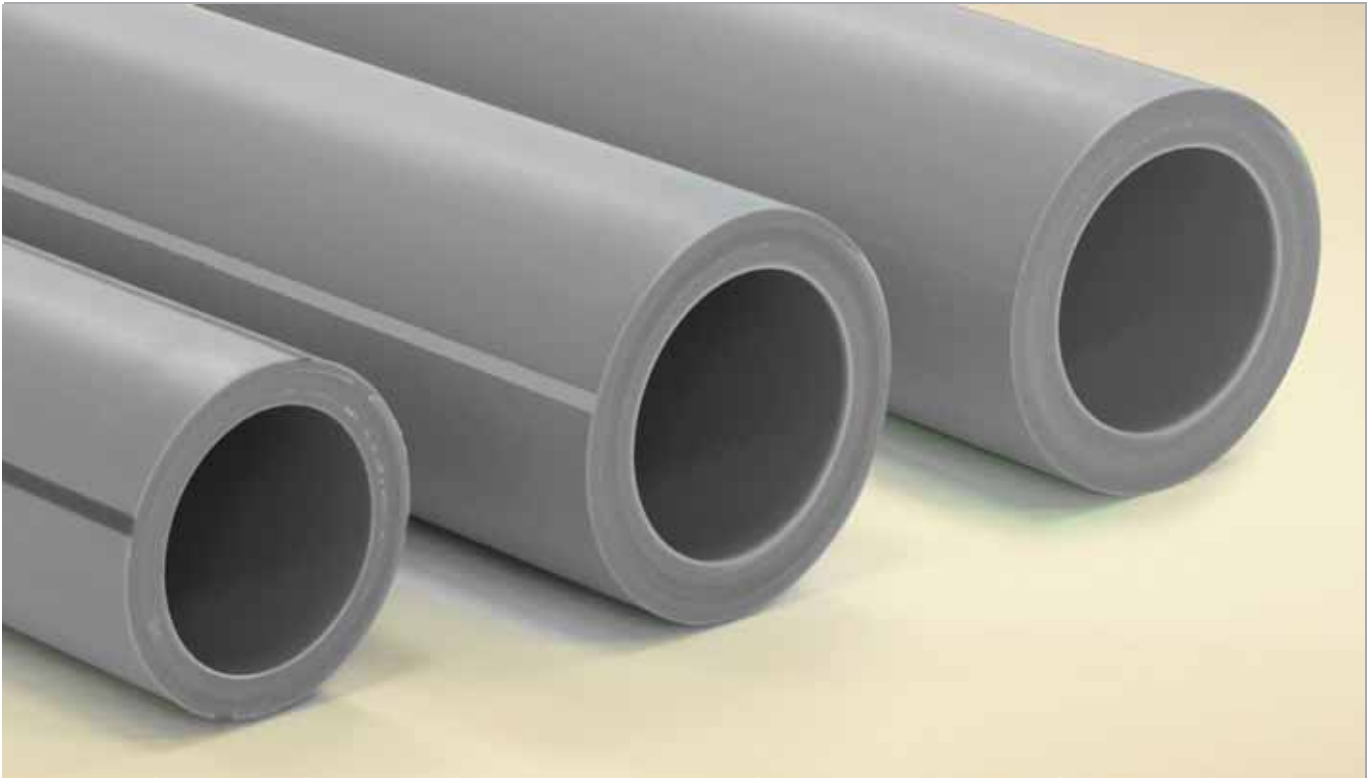

	HVACR							
Drinking water		Swimming pools	Chemical fluids	Recycled water	Compressed air	Heating	Geothermal applications	Ship building industry
●								●
●	●	●	●		●	●	●	●



SPECIAL APPLICATIONS

NIRON® PURPLE PPR PIPE



WATER RECYCLING SYSTEMS

The **average consumption** of a four person individual house in a temperate climate is over **200,000 liters of water per year**, around 17,000 liters per month.

In a water recycling system, wastewater or rain-water is routed to a central sump basin to be recycled. The sump then moves the water through some filtration stages and starts a disinfection cycle before entering the storage tank. On a pre-determined schedule, a timer controlled pump recirculates water in the storage tank through the entire filtration process to maintain it clear and bacteria free. Recycled water in the storage tank is drawn out by a pressure regulated pump. When the irrigation timer turns on or a toilet is flushed, the system automatically provides the recycled water stored in the storage tank. When the storage tank is full, excess water drains into the sewage system.

For commercial building owners the need to **store water** is a **mandatory requirement**. Additionally, it is simply the right thing to do, both from a financial and environmental point of view.

Resort, hotel and shopping mall owners who have to deal with a **high number of visitors** are increasing water storage especially in arid climates where lush foliage and landscaping is mandatory for visitors.

The use of recycled water will have a huge impact on operating costs and profitability. Therefore, NIRON offers its users a piping range that allows for this type of installation. The color is in accordance with international standards regarding "waste and recycled water systems" and can immediately identified as piping for recycling application due to its **PURPLE** color.



	HVACR							
Drinking water		Swimming pools	Chemical fluids	Recycled water	Compressed air	Heating	Geothermal applications	Ship building industry
				●				



SPECIAL APPLICATIONS

NIRON® MANIFOLDS



DISTRIBUTION MANIFOLDS

Nowadays, more and more companies choose polypropylene manifolds.

Installations are often required to serve high flow rates and their weight and implementation difficulties require special expensive equipment.

Its range of welding saddles allows Nupi Americas to make distribution manifolds in just a few steps.

The company also provides a technical service whose task is to make and test the manifolds needed for a specific project as per customers' needs according to water tightness tests as per our in-house recommendations and those of CEN TR 12108.

Nupi Americas has a special department dedicated to these manifolds and equipped with specific equipment and programs for their design and making according to customers' requirements. This department offers assistance during the installation and facilitates the work of project managers and installation professionals thanks to the versatility offered by **NIRON PIPING SYSTEMS**.





	HVACR							
Drinking water		Swimming pools	Chemical fluids	Recycled water	Compressed air	Heating	Geothermal applications	Ship building industry
●	●	●	●			●	●	●



SPECIAL APPLICATIONS

NIRON® PREINSULATED



PREINSULATED PIPE

NIRON is available in an innovative PRE-INSULATED Pipe and Fitting System that is ideally suitable for application in areas where heat loss or heat gain needs to be minimized.

This product range is specifically designed for networks for central distribution of both hot and cold fluids.

The reliability, ease of installation and relevant physical-mechanical properties of the materials used allow installers to overcome many problems previously encountered when installing central heat distribution and central chilled water distribution systems.

THERMAL INSULATION (PUR)

The insulation of the primary pipe is made with a highly energy efficient rigid polyurethane foam. The coefficient of thermal conductivity is 1.67 BTU-inch/hr-ft²-°F (0.24 W/m²K) when measured at a temperature of 68°F (20°C).

This excellent characteristic of the PUR insulation allows high levels of thermal insulation value with significantly reduced insulation thickness compared to that which would be required compared to other insulating materials.

In addition, due to its closed cell structure, under normal conditions of use it does not experience any transformation caused by water absorption, compression, sacking, etc.

JACKET PIPE (PVC and HDPE)

The polyurethane insulation layer is protected by jacket piping and fittings made from either rigid PVC or High Density Polyethylene (HDPE).



	HVACR							
Drinking water		Swimming pools	Chemical fluids	Recycled water	Compressed air	Heating	Geothermal applications	Ship building industry
	○	○	○			○	○	○

■ APPLICATIONS

- District heating/cooling
- Transport of energy on site and remote
- Transport of water
- Cooling systems
- Geothermal systems
- Industry and agriculture

■ BENEFITS

- Ease of installation and reduced installation time
- Excellent thermal insulation
- Low specific weight
- Low pressure drop
- Excellent weldability thanks to the fittings of the NIRON range
- High resistance to corrosion
- High durability
- Reliable junction
- Resistance to abrasion
- Resistance to stray currents



SPECIAL APPLICATIONS

PPR PIPING SYSTEM

NERO by
NIRON®



UV RAY PROTECTION PIPE

NERO by NIRON is a pipe produced using PP-RCT material with an outer layer of POLYPROPYLENE duly UV stabilized with a dedicated masterbatch. This outer layer allows the pipe to be used for installations where UV protection is not guaranteed or adequate.

CHARACTERISTICS

NERO by NIRON is produced in composite material with addition of fiberglass.

As the stress-bearing layer is made with PP-RCT, it has the high, well known and standardized performances of this class of polypropylene. The mechanical and physical properties fully comply with EN ISO 15874 and ASTM F2389 Standard. The pipe is compliant to the main Standards for the conveyance of potable water.

It can be produced in different SDRs (SDR 11 and SDR 17). The selection of the proper SDR and design is related to the required operating conditions.

The pipe has been designed with the highest safety standards. The UV barrier layer is in fact in addition to the SDR stress-bearing layer of the pipe maintaining the nominal OD of the pipe.

The Nominal Diameter is maintained to facilitate the welding operations.

NERO by NIRON piping range goes **from Ø1" to Ø16"**. Bigger sizes can be provided upon request.



	HVACR							
Drinking water		Swimming pools	Chemical fluids	Recycled water	Compressed air	Heating	Geothermal applications	Ship building industry
	●		●			●	●	●

- NO PHOTOCHEMICAL ATTACK TO THE POLYMER STRUCTURE
- NO PIGMENTATION CHANGE
- NO CRACKING
- NO THICKNESS REDUCTION DUE TO LIGHT DAMAGE
- TOTALLY COMPATIBLE WITH THE FITTING RANGE

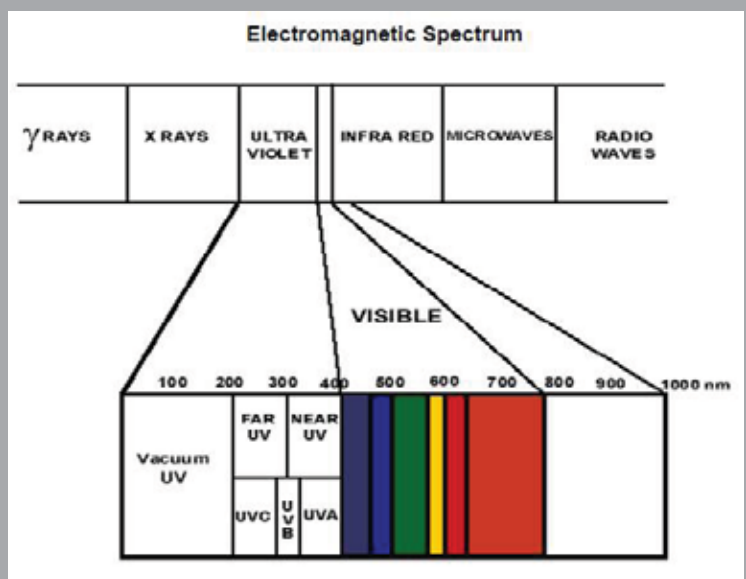

NIRON[®]

PP-RCT PIPING

SYSTEMS

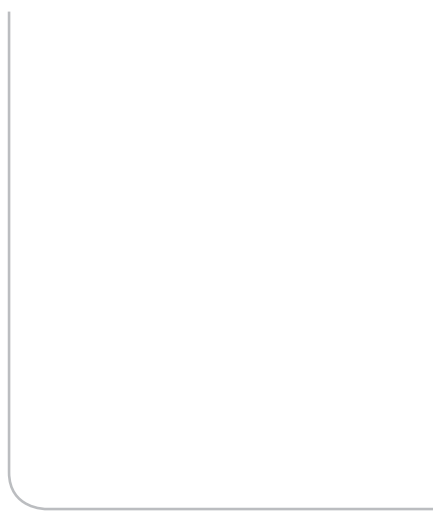



2

TECHNICAL CHARACTERISTICS

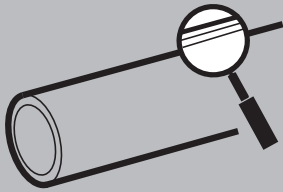

NO CORROSION

PP-RCT pipes are resistant to any type of water hardness and bear many of the chemical substances with pH values between 1 and 14. PP-RCT is resistant to alkalis and instead shows some weakness against some strong acids.

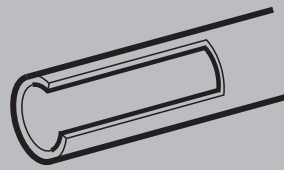

NO SCALING

The inner smoothness of pipes prevents the formation of scale.

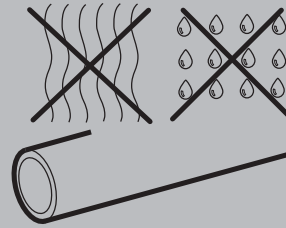

LIMITED HEAT LOSS AND CONDENSATION

Like all plastics, PP-RCT is a poor heat conductor, and is therefore an excellent thermal insulator. Where it is allowed by the energy code, the amount of insulation can be reduced or eliminated.

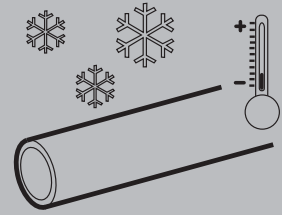

FROST RESISTANCE

The elasticity of PP-RCT allows the pipe to increase its section when the volume of the iced fluid inside changes.

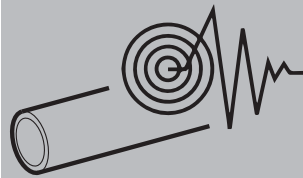

SUITABLE FOR USE IN SEISMIC HAZARD AREAS

This feature is recognized by international boards of experts, as polypropylene is resilient within the structure of a building.

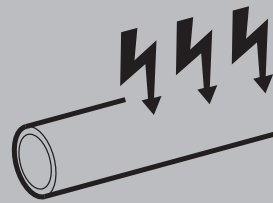

RESISTANCE TO STRAY CURRENTS

Polypropylene is a very poor conductor of electricity, so no perforation in the pipe or fittings will ever occur due to stray currents.

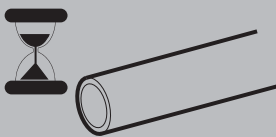

DURABILITY

Lifetimes of more than 1,000 years (depending on wall thickness, temperatures and working pressures).

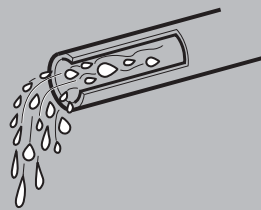

RESISTANCE TO ABRASION

The high abrasion resistance of NIRON PIPING SYSTEMS allows the passage of water at high speed without erosion problems.



LIMITED HEAD LOSS

NIRON pipes have limited head loss because their surface is smooth and presents no scaling.

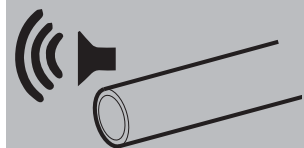

LOWER NOISE OF THE SYSTEM

The elasticity and the sound absorption of the material absorb and prevent the spread of noise and vibrations due to the passage of water and the water hammer effect.

2.1 BENEFITS



- Corrosion resistance
- Scaling resistance
- Frost resistance
- Limited heat loss and condensation
- Low noise
- Limited head loss
- Abrasion resistance
- Resistance to stray currents
- Durability and lightness

2.1.1 POLYPROPYLENE

The polypropylene used in the NIRON PP-RCT PIPING SYSTEM is a special type of Random Copolymer with high molecular weight and which has extensive beta crystalline formation of the molecules.

The extensive crystallinity results in exceptionally high pressure resistance, especially at elevated temperature. It also allows exceptional chemical resistance, especially to highly oxidizing compounds such as chlorine.

PP-RCT is very light and easy to process, therefore the material is effectively used to produce a complete system that allows installation time savings from 30 to 50 %, if compared to the traditional metal systems (steel and copper).

NIRON PP-RCT PIPING SYSTEMS are used for the conveyance of drinking water and in heating and cooling applications. Niron may also be used in the industrial, agricultural and shipbuilding fields.

The raw material is supplied by international certified suppliers and complies with the most important sanitary requirements for the transport of drinking water and contact with food surfaces and fluids.

2.1.2 PROPERTIES OF THE MATERIAL (PP-RCT)

Properties	Test method	Values at 23°C	Unit of measure
Volumic mass	ISO 1183	56.06	lb/ft ³
Yield strength	ISO 527	3,336	lb/in ²
Elongation at break	ISO 527	> 50	%
Modulus of elasticity	ISO 527	123,300	lb/in ²
Liquidity index	ISO 1133	0.011	lb/10 min
Heat conductivity (λ)	DIN 52612	1.70	BTU-in/hr-ft ² -°F
Linear thermal expansion	VDE 0304	8.33 x 10⁻⁵	°F ⁻¹
Melting range	DIN 53736b2	302 - 309	°F
Impact strength +73.4°F	ISO 179/1 e A	no break	ft-lbs/in ²
-22°F	ISO 179/1 e A	23.8	ft-lbs/in ²
Volumic strength	IEC 93	> 6.0 x 10²²	circ mil Ω /ft
Dielectric strength	IEC 243/1	1.905	KV/mil
Loss factor	DIN 53483	< 5 x 10⁻⁴	
Fire resistance		B2	



2.1.3 CERTIFIED QUALITY

- GENERAL QUALITY AND DIMENSION REQUIREMENTS

ASTM F2389 Standard Specification for Pressure-rated Polypropylene (PP) Piping Systems

CSA B137.11 Polypropylene (PPR) Pipe and Fittings for Pressure Applications

UNI EN ISO15874 Plastics piping systems for hot and cold water installations - Polypropylene

DIN 8077 Polypropylene (Pp) Pipes - Pp-H, Pp-B, Pp-R, Pp-Rct - Dimensions

DIN 8078 Polypropylene (Pp) Pipes - Pp-H, Pp-B, Pp-R, Pp-Rct – General quality requirements and testing

- HYGIENIC LAWS AND SPECIFICATIONS

NSF 61 Drinking Water System Components - Health Effects

- INSTALLATION STANDARDS

ANSI/ASME B31 Pressure Piping Code (ANSI/ASME B31.1, B31.3, B31.9)

EN 806 Specifications For Installations Inside Buildings Conveying Water For Human Consumption

DIN 1988 Codes of practice for drinking water installations - DVGW code of practice

DVS 2207 Welding of thermoplastic materials

DVS 2208 Welding machines and devices for thermoplastics

CERTIFIED QUALITY

The quality of the PP-RCT PIPING SYSTEM is guaranteed by numerous national and international independent bodies.



2.1.4 CONTROL SYSTEM

The production of pipes and fittings requires the supervision, regulation and control of all of our working operations. All results are recorded and documented.

OUR STANDARD INCLUDES:

- acceptance testing of raw materials and incoming goods;
- process control;
- inspection and testing of products;
- final inspection and sample tests on the production batches.

This procedure is required by the standard that regulates the Quality Management System (UNI EN ISO 9001) and the relevant protocols for the quality control of piping systems (e.g. ASTM F2389, NSF-14, NSF-61, CSA B137.11, UNI EN ISO 15874).

INTERNAL CONTROL

Skilled employees ensure that all assessments are carried out according to the appropriate regulations and fulfill all technical arrangements in accordance with the quality policy.

All internal quality controls are documented, recorded and stored in accordance with the provisions of applicable laws and regulations.

2.1.5 QUALITY ASSURANCE

ACCEPTANCE OF INCOMING GOODS

All incoming goods are subject to specific tests that guarantee that incoming products conform to the specified requirements.

INSPECTION AND TEST

The quality plan adopted by NUPI AMERICAS requires that tests and inspections are carried out before and during the production process. During the production phase, the quality plan establishes that products pass the following tests:

- dimensional check;
- surface check;
- marking check;
- control of process parameters.

The samples are collected and sent to the quality department that performs quality checks and performance testing on the products and submits them to various degrees and types of stress (pressure, temperature, oxidation, etc.).

FINAL INSPECTION AND TESTING

The quality plan adopted by NUPI AMERICAS requires that the inspections and tests are carried out on the entire production cycle.

All test results are documented in the test report and the certificate 3.1 (available on request).

Final tests include:

- internal pressure test at 203°F (95°C) (time and pressure are specified in the reference standard);
- cold impact test;
- oxidation induction time;
- melt flow index;
- homogeneity test with polarized light microscopy;
- dimensional checks;
- elongation test with dynamometer;
- tensile test (> 3,335 psi; > 23 N/mm²) with dynamometer.

After the final tests, more tests are carried out on some batches:

- temperature cycle test: pipes and fittings are subjected to temperature cycles designed to last for 15 minutes at 203°F (95°C) and 15 minutes at 68°F (20°C) with a pressure of 145 psi (10 bar) for a total of 5,000 cycles;
- oxidation induction time: determining the percentage of antioxidants in the product after the extrusion process;
- thermal stability at 230°F (110°C) for 8,760 hours (= 1 year).

STORAGE/PACKING/SHIPPING

Upon positive test results, the products are suitably packaged and stored in suitable warehouses.

INTERNAL CONTROL - SYSTEM CONTROL

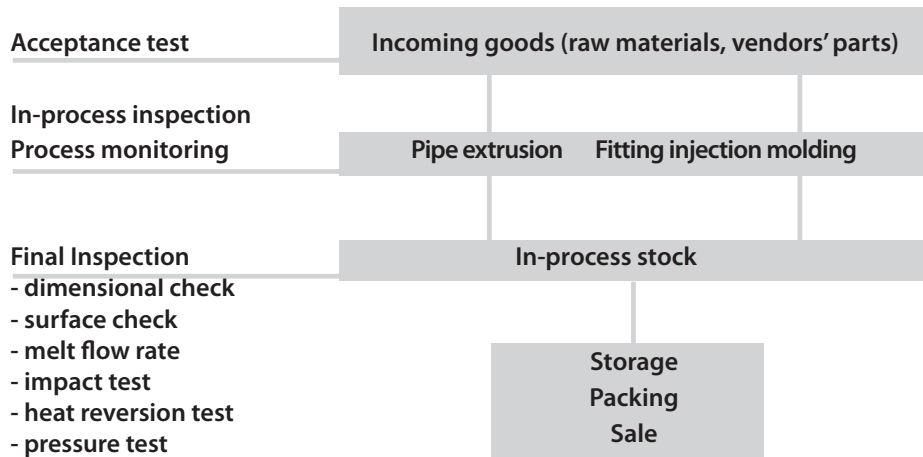

EXTERNAL AUDIT

NUPI submits its management and production system to external audits performed by third party certification bodies.

The external audit consists of tests carried out at given intervals.

Audit frequency depends on the procedure established by the specific standard and by each certification body.

The external supervision also provides:

- verification of the quality system;
- calibration of test equipment;
- hygiene and toxicity tests.

The results are confirmed by test certificates obtained by the company.

2.2 PRESSURE RATINGS FOR NIRON PP-RCT PIPE

Maximum Recommended Operating Temp. for Niron = 203 °F

Minimum Recommended Operating Temp for uninsulated Niron = 23 °F (for temps below 50 °F use stated pressures at 50 °F)

SUSTAINED PRESSURE RATINGS FOR HVAC AND INDUSTRIAL APPLICATIONS (PSI)

Temp °F	Niron Clima Niron Mono Grey SDR 7.3	Niron Clima Niron Mono Grey SDR 9	Niron Clima Niron Dark Niron Mono Grey SDR 11	Niron Clima Niron Dark Niron Mono Grey SDR 17
	Pressure Rating (psi)			
≤ 50	482	381	303	191
68	418	331	263	165
86	360	286	226	142
104	308	244	193	122
122	261	207	164	103
140	223	177	141	89
158	187	148	118	74
176	158	125	100	62
203	120	96	75	48

SUSTAINED PRESSURE RATINGS FOR POTABLE WATER APPLICATIONS (PSI)

Temp °F	Niron Clima Niron FG RED SDR 7.3	Niron Clima Niron FG RED SDR 9	Niron Clima Niron FG RED Niron Blue / Mono Grey SDR 11	Niron Clima Niron Blue Niron Mono Grey SDR 17
	Pressure Rating (psi)			
68	418	331	263	165
86	360	286	226	142
104	308	244	193	122
122	261	207	164	103
140	223	177	141	89
158	187	148	118	74
176	158	125	100	62
203	120	96	75	48



CAUTION

The longevity at the stated pressures and temperatures will vary greatly at elevated temperatures based on the level of chlorine present in the water and the duration of hot water exposure. For hot water applications involving greater frequency than CL-TD (Class 1), it is highly recommended to use SDR7.3 wall thickness for maximum longevity.



SUSTAINED PRESSURE RATINGS FOR NON-FILTERED COMPRESSED AIR APPLICATIONS (PSI)

Temp °F	Niron Clima Niron Mono Grey SDR 7.3	Niron Clima Niron Mono Grey SDR 9	Niron Clima Niron Dark Niron Mono Grey SDR 11	Niron Clima Niron Dark Niron Mono Grey SDR 17
	Pressure Rating (psi)			
≤ 50	400	318	252	160
68	348	276	219	138
86	299	238	189	119
104	255	203	161	102
122	218	173	136	86
140	186	148	118	74
158	155	123	99	61
176	132	104	83	52
203	100	80	62	39

NOTICE

Sustained pressures are based on water and with industry standard safety factors. Pressure ratings shown are based on the longest time for extrapolation allowed according to ISO 9080 and in compliance with the German standard DIN 8077.

The above data have been derived selecting a Safety Factor (SF) = 1.25 for HVAC, industrial and potable water applications and 1.5 for compressed air.

2.3 HOOP STRESS DATA FOR NIRON PP-RCT PIPE

REGRESSION CURVES FOR PP-RCT AND PP-R

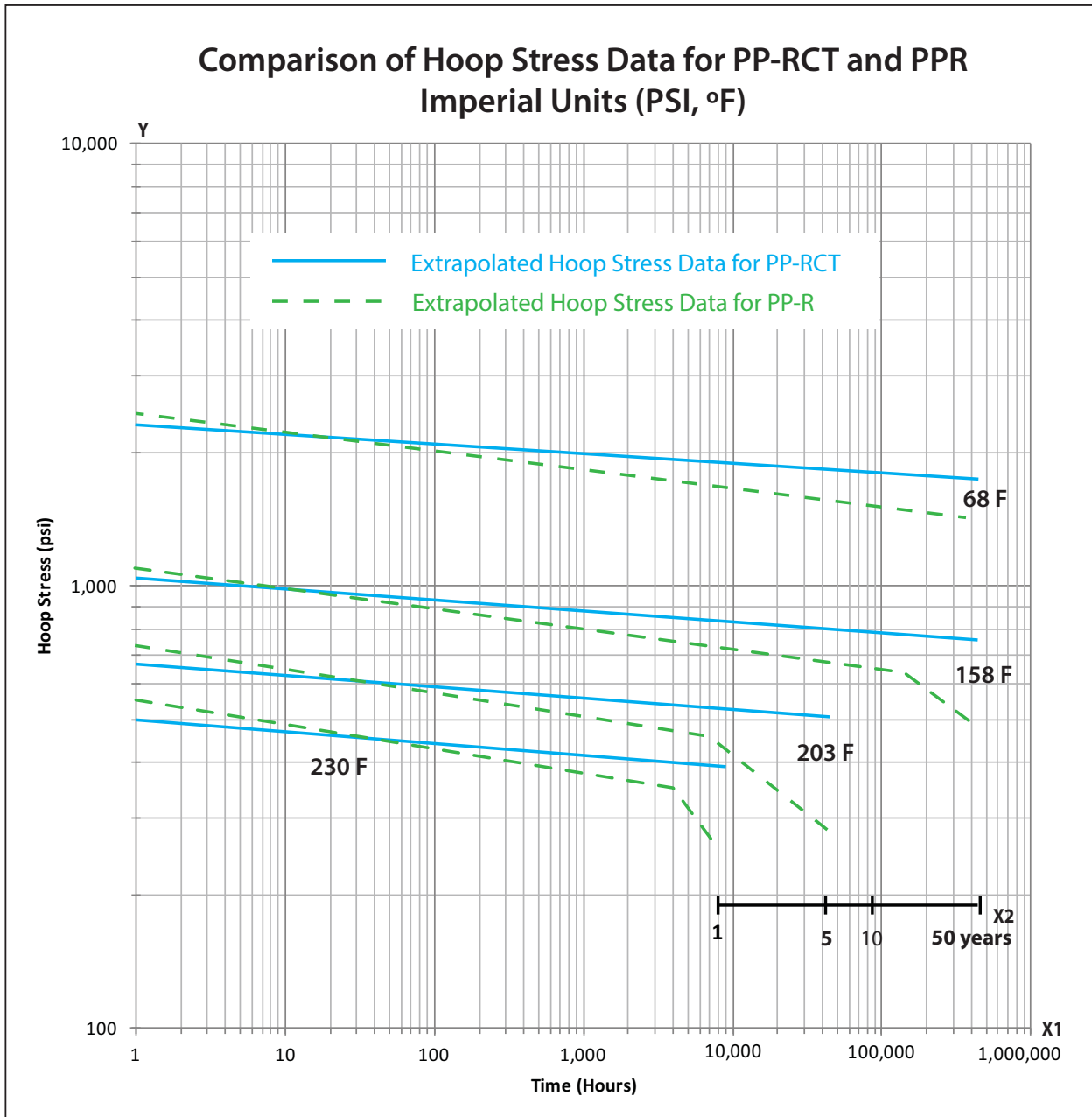

Key
X1 time, t_1 , to fracture, in hours
X2 time, t_2 , to fracture, in years
Y hoop stress, σ , in psi

NIRON[®]

PP-RCT PIPING

SYSTEMS

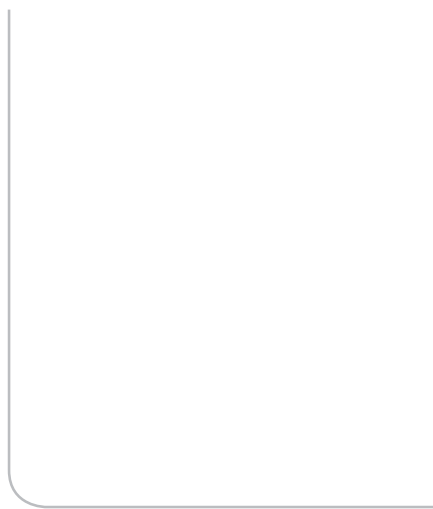













WELDING SYSTEMS

3.1 WELDING EQUIPMENT

- 1) Welder model **00NSBEP/110** (800 W - 110V – 50/60 Hz) supplied in a special carrying case, complete with die pairs required for the welding of diameters ½" - ¾" - 1" (20 - 25 – 32). The welder is equipped with an automatic thermostat to maintain the temperature of the die pair constant at 500 ± 18°F (260 ± 10°C).
- 2) Welder on wheels model **00STL125** (1400 W - 110V - 50/60 Hz) is supplied on pallet complete with die pairs from diameter ¾" (25mm) to diameter 5" (125mm) and pipe support.

Equipment	Item code	Power supply	20	25	32	40	50	63	75	90	110	125	160	200	250	315	355	400	450	500	560	630
	NSBEP/110	800W	X	X	X	Die pairs included: 20mm - 25mm - 32mm																
	NPCCE/110	800W	X	X	X	X	X	X	Die pairs NOT included													
	NPCCE125/110	1400W	X	X	X	X	X	X	X	X	X	X	Die pairs NOT included									
	STL125/110	1400W	X		X	X	X	X	X	X	X	X	Die pairs included									
	E9001SL/110	500 VA	X	X	X	X	X															
	E9001LP/110	1500VA	X	X	X	X	X	X	X	X	X	X	X									
	E9001P/110	2000VA	X	X	X	X	X	X	X	X	X	X	X	X	X	X	X	X				
	SMARTWELDL/110	1500VA	X	X	X	X	X	X	X	X	X	X	X									
	SMARTWELD/110	2000VA	X	X	X	X	X	X	X	X	X	X	X	X	X	X	X	X				
	E9001	2500VA	X	X	X	X	X	X	X	X	X	X	X	X	X	X	X	X	X	X	X	X

- 3) The multifunction electrofusion welding machine for electrical fittings with automatic insertion of the parameters are available in several models:
- **9001SL/110** welding unit **SUPER LIGHT** with barcode scanner for fittings until $\varnothing 2"$.
 - **9001LP/110** and **9001P/110** multifunction welding unit incorporate in **Pelican Case**.
 - **SMARTWELD/110** and **SMARTWELDL/110** multifunction welding unit incorporate in Pelican Case and associated with the **APP 'Nupi Welding Cloud'**.
 - **E9001/110** multifunction welding unit for big diameters **until $\varnothing 24"$** .

Both welding machines are equipped with a power cable 13.1 feet (4 m) long, barcode scanner, adapters $\varnothing 4,7\text{mm}$ pins and USB key for data download.



SMARTWELD/110



NSBEP/110



NPCCE/110



NPCCE125/110

Technical data

Voltage	110V - 800W 50/60 Hz
Working temperature	500°F ($\pm 18^\circ\text{F}$)
Outside temperature range	23°F \div 104°F
Material	HDPE, PP, PP-R, PB, PVDF

Models	Nominal size range	Power supply	Dimensions (W x D x H)	Weight
NSBEP/110	1/2" \div 1"	800 W	4.5"x1.9"x 14.2" H	3.170 lb
NPCCE/110	1/2" \div 2"	800 W	6"x1.4"x 14.2" H	4.010 lb
NPCCE125/110	1/2" \div 5"	1400 W	6.8"x1.9"x 15.5" H	8.820 lb



Technical Data for STL125/110

Working range	3/4 to 5 inch
Voltage	110V - 50/60 Hz
Total absorbed power	1400W
Working temperature	500°F (± 18°F)
Room temperature range	+23°F ÷ +104°F
Time to reach welding temperature	~ 10 min.
Materials	PEAD, PP, PPR, PP-RCT, PB, PVDF



Dimensions (W x D x H) and Weight

Machine	42 x 33 x 22 inch
Carrying case	approx 60 x 31 x 51 inch
Weight	220 lbs

3.2 SOCKET FUSION WELDING

3.2.1 WARNINGS AND PRELIMINARY RECOMMENDATIONS

Socket fusion welding is one of the most widely used joining techniques for the installation of heat fusible thermoplastic piping such as PP, PE and PVDF. There are just a few and simple steps necessary to complete it, but they require the attention of the contractor.

Welding equipment check:

The welding equipment to be used must be inspected and checked thoroughly to insure they are in proper working condition.

In particular you should carry out the following operations:

- Check the functioning of the thermostat by measuring the temperature on the surface of the bushings with an appropriate contact thermometer 500°F (260°C).
- If you are using a bench machine, check the functioning of the clamps and the handling system of the welding machine so as to ensure the proper alignment of the parts to be welded.
- Inspect the integrity of the non-stick coating of the bushings.

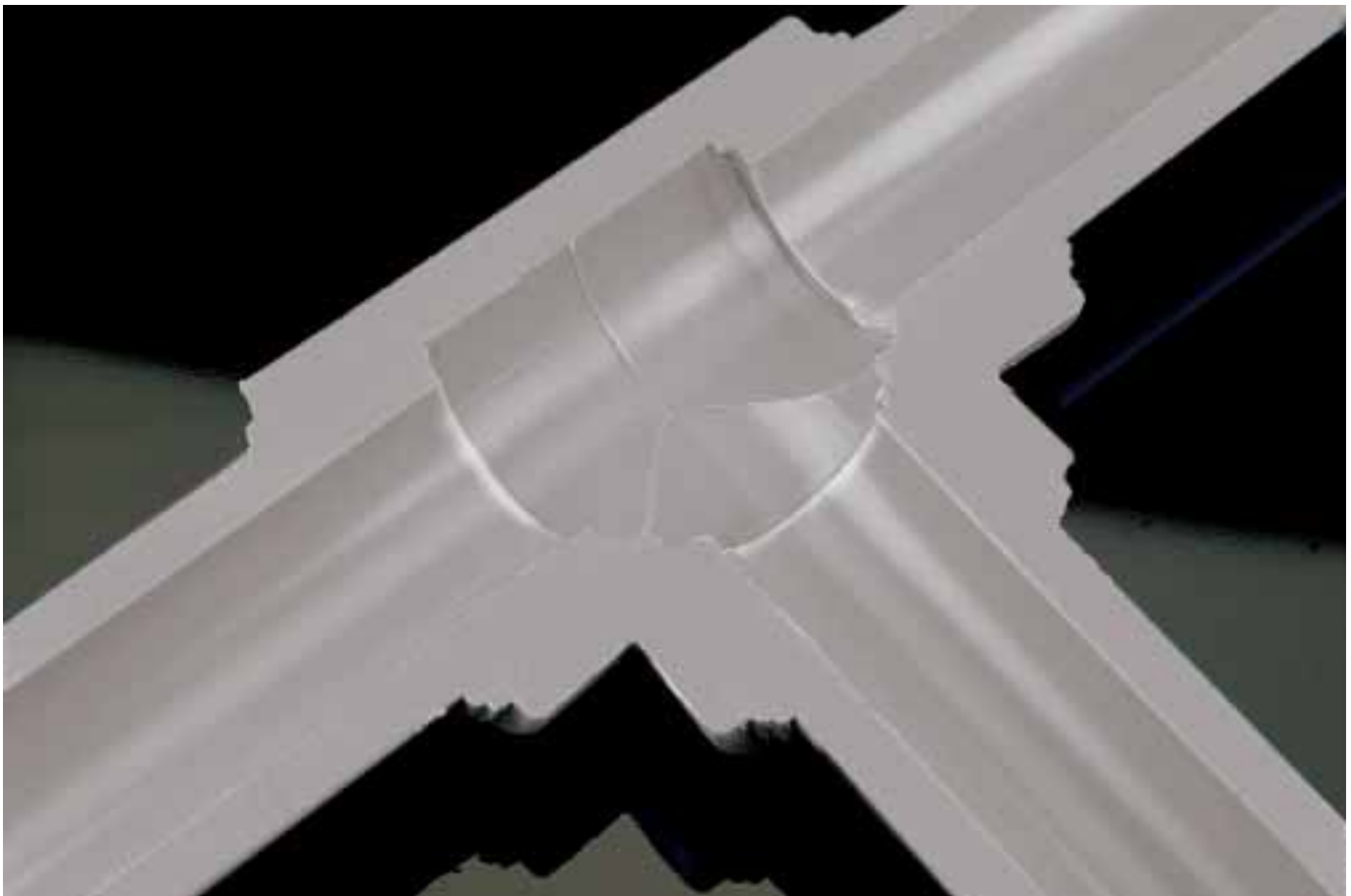

When a perfect socket fusion welding of the NIRON PP-RCT PIPING SYSTEM has been properly carried out, the welded joint will result in homogeneous bond. If the joint is sectioned, you will not be able to distinguish where the pipe ends and the fitting begins.

3.2.2 SOCKET FUSION WELDING: FITTINGS

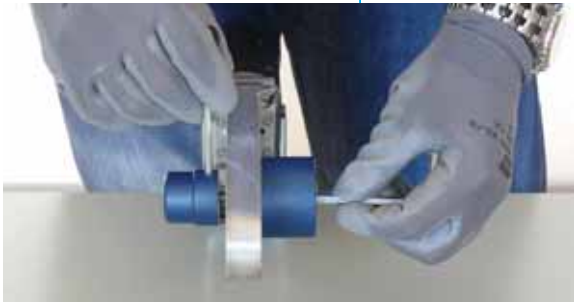

Assemble the male and female heater bushings on the cold plate and connect the welder to the power network. Wait for the sound or light signal (see the user's manual of the welder) that informs that the actual temperature is reached.



Cut the tube perpendicularly to its axis using the suitable pipe cutter.



After cutting, bevel the square cut end of the pipe to produce a 15° bevel using the Niron beveling tool, or other suitable bevelling tool.

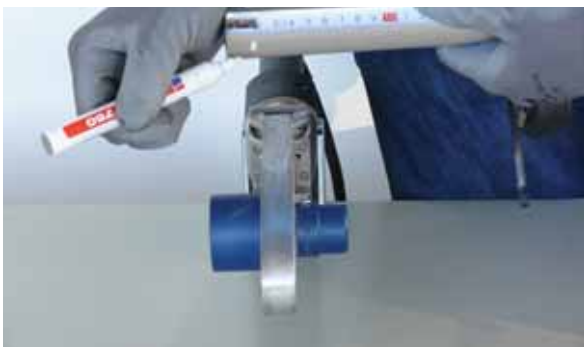

Mark the insertion depth on the pipe for type A sockets according to the chart provided. A second mark should be made a distance of 1/16 inches past the first mark. The first mark will be hidden from view after welding by the weld bead when properly made. The second mark allows for visual inspection to verify that depth of insertion marking was performed after the external bead is formed.

Make a longitudinal mark as a reference on the external surfaces of the pipe and fitting to avoid turning the components to be welded while performing the welding procedure (do not cut the surface of the pipe and fitting).

Although it is required in international standards (e.g. in DVS 2207-11, part 5) that the pipe surface and interior of the socket be cleaned with isopropyl alcohol prior to welding, this is viewed as highly conservative and is only necessary if the parts have signs of containing dirt, grease and other contaminants. If the parts are in clean condition (e.g. they have been taken from their factory packaging and there is no sign of contamination), then cleaning is not necessary). Place the ends to be welded close to each other to be able to begin the heating process of the components simultaneously.

After checking the surface temperature of both of the bushings, insert the pipe into the female bushing without rotating it and the fitting over the male bushing up to the depth previously marked. This position should be maintained for the heating time as shown in table A (page 56). Do not heat up the parts to be welded twice.

During the heating, be careful not to put excessive force on the parts as this might cause the female heater bushing to melt too far into the fitting or coupling socket. After the heating time, quickly remove the elements from the bushings and insert them one inside the other, within the maximum changeover time, until you reach the insertion depth previously marked.

Be careful not to rotate the pipe into the fitting and carefully align the reference longitudinal signs. Keep the welded parts together under force for the time shown in the cool down time (clamped) in Table A. Then, allow the welded parts to cool according to the total number of minutes shown in Table A before placing the welded parts under a pressure test.

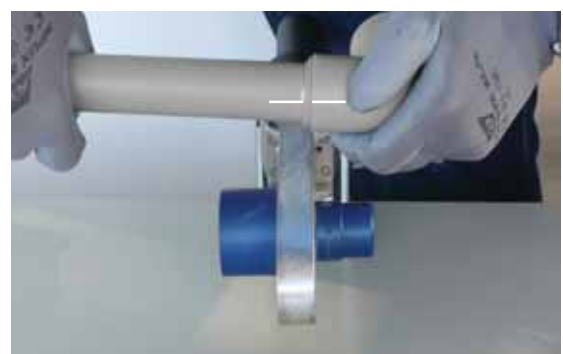
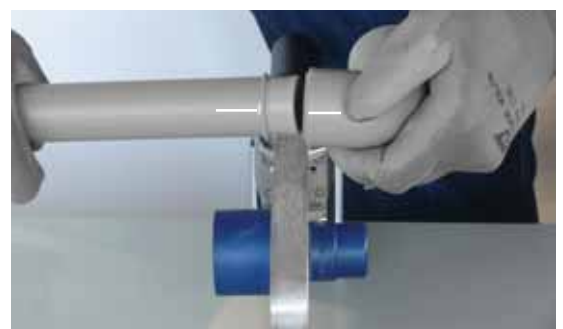

TABLE A- SOCKET WELDING PARAMETERS

Branch connection sizes	Depth of insertion 1 st mark	Heating Up Time (seconds)		Max Change-over (seconds)	Cool Down Time	
		SDR 11 SDR 7.3	SDR 17		Clamped (seconds)	Total (minutes)
1/2" (20 mm)	0.55 (9/16")	5	NA	4	6	2
3/4" (25 mm)	0.59 (19/32")	7	NA	4	10	2
1" (32 mm)	0.65 (21/32")	8	NA	6	10	4
1"1/4 (40 mm)	0.71 (23/32")	12	NA	6	20	4
1" 1/2 (50 mm)	0.79 (25/32")	18	NA	6	20	4
2" (63 mm)	0.94 (15/32")	24	10	8	30	6
2"1/2 (75 mm)	1.02 (17/32")	30	15	8	30	6
3" (90 mm)	1.14 (1 - 1/8")	40	22	8	40	6
4" (110 mm)	1.28 (1 - 1/4")	50	30	10	50	8
5" (125 mm)	1.38 (1 - 3/8")	60	35	10	60	8

Inside Nupi Americas' welding case (where a tool is used that is supplied by Nupi Americas, this will not be true when using welding devices supplied by others) you will find a sheet that shows the welding parameters (diameter, pipe insertion depth, heating time, fusion time and time prior to testing).

3.2.3 SOCKET FUSION WELDING: INSTABRANCH™ FITTINGS

Threaded, unthreaded and PEX transition Instabrand™ Fittings allow reduced branches to be made directly onto larger diameter pipes. They also allow for the fabrication of pipe headers (e.g. for water meters).

Drill a hole in the pipe with the proper Niron cutter (item code 00FGS) at the point where you want to make a new branch reduction.

Make sure that the parts to be welded (especially the pipe) are clean and dry. It is highly recommended, but not required that the surfaces to be welded be scraped and prior to cleaning, especially when it is a possibility that the pipe may have been exposed to sunlight.

Check that the welder and die pairs have reached the correct operating temperature of 500°F (260°C).

Insert the male die pair into the pipe hole until the concave part touches the outer surface of the pipe.





Insert the fitting into the female die pair simultaneously. The contact times between die pairs, fitting and pipe shall be those listed in Table A in the Socket Fusion section. The size of the reduced branch is the size that dictates the times to be followed from Table A. For example, if the branch size is 1", then use the heat up time indicated in Table A for the 1" size. In any case, a visual check should be performed during the heating to insure that there is a double bead around the entire contact area of the weld surfaces.

Once the heating time is over, immediately insert the welding saddle into the heated hole without turning. The fitting must be perfectly fixed and pressed against the pipe surface for about 30 seconds.

After a cooling time of 10 minutes, the new joint can be pressure tested or placed into operation. This differs from normal socket fusion in that this time is longer in all cases compared to the times shown in Table A.

When making double pipe arrays for water meters we suggest to:

- Mark in advance the two opposing drilling axes.
- Make all the holes at the same time with a proper drill bit.
- Make the joints in a staggered manner.

3.2.4 POLYFUSION WELDING: REPAIR OF A PIPE DAMAGED BY NAILS OF SCREWS

This system applies when a pipe or a fitting have been pierced on one side (e.g. by a nail or drill) and perpendicularly to their axis.

Enlarge the hole up to a diameter of 6 mm (approx. ¼") or 10 mm (approx. ⅜") with a suitable drill bit.

Make sure that the hole caused by the puncture has not damaged the other inner surface of the pipe or fitting.

Insert the proper size male die pair into the pipe hole and the repair cap into the female die pair.

After the insertion, heat up for 5 seconds.

Once the heating time is over, insert the male plug (rod) cap inside the hole without rotating.

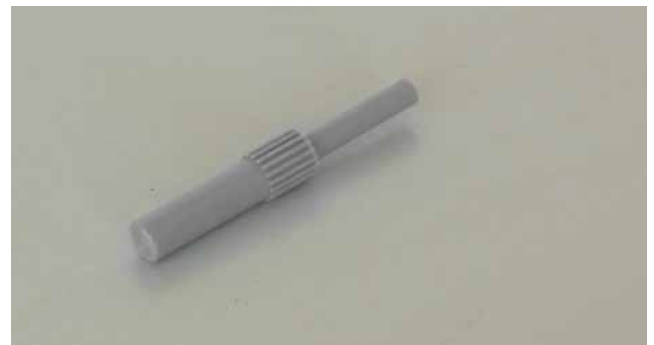



Wait for a cooling time of 1 minute and cut the cap.



The picture shows how the pipe looks after the repair.

3.3 ELECTROFUSION WELDING

Electrofusion fittings and couplings are manufactured with a molded-in-place resistance wire which can be connected to suitable welding machines by means of a set of connecting wire leads.

When voltage is applied and electrical energy is circulated, this creates resistance which generates the heat needed to melt the PP-RCT material.

Energy is directly transmitted to the contact surface between the fitting and the pipe causing heat welding of the parts.

The main features of NIRON electrofusion fittings are the high quality, repeatability and the reliability of the joints. After a joint is completed and is allowed to cool, the joint is homogeneous, strong, safe and reliable.

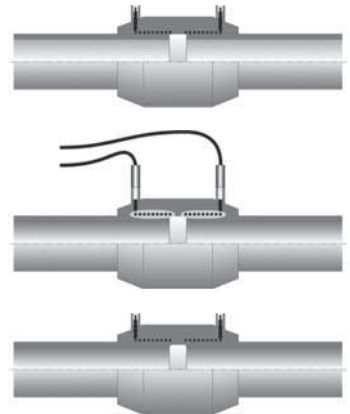

WELDING BARCODE (in conformity with standard ISO13956)

Scan the barcode with the barcode scanner or manually enter the welding parameters of time and voltage reported on the barcode. The welding procedure may be carried out by using the multifunction welding unit in automatic mode (with barcode scanner) or in manual mode. When performing automatic welding, always check time and voltage parameters on the display after scanning the barcode. In case of manual welding, use time and voltage parameters indicated on the barcode. If the welding unit selected is not a Nupi Americas unit, and does not perform welding time compensation according to ambient temperature, use the parameters on the bag label.



N.B.: Keep at a safe distance during the welding procedure.

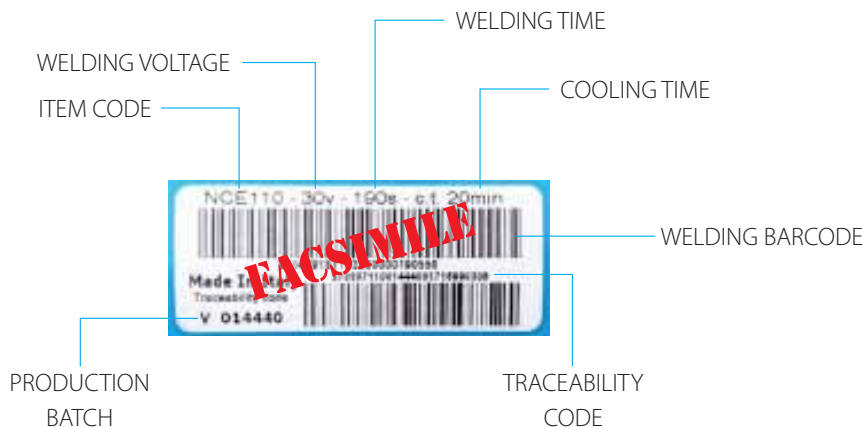



Use NIRON welding units (when possible) and follow the instructions below to obtain a reliable weld.

Cut the pipes at right angles with a pipe cutter.

ATTENTION!

Note that the cutting of Niron PP-RCT pipes to result in a square cut is a critical step in the process of electrofusion.



Scrape the pipe or fitting spigot surface uniformly with the appropriate pipe scraper. Scrape at least $\frac{3}{8}$ " (1 cm) beyond the insertion length of the fitting to completely remove the oxidized polypropylene layer. The pipe or fitting spigot surface must be marked with a sharpie prior to scraping and the mark must be removed by scraping (The depth of insertion mark will be reapplied after cleaning see below). The pipe/spigot surface must be scraped to a minimum depth of 0.2mm (0.0079 inch) in order to be considered properly scraped. If the pipe/spigot fits too tightly into the socket, the scraping step should be repeated until a light press fit is obtained.



Niron mechanical scrapers are highly recommended. Hand scrapers can be used only if proper technique is followed to result in 0.2 mm (0.0079 inches) removed.

ATTENTION!

The pipe/spigot surface must be scraped to a minimum depth of 0.2mm (0.0079 inch) in order to be considered properly scraped. Additional scraping can be performed, if necessary, in order to achieve a light press fit of the pipe/spigot into the socket.



Remove any mud, dust, grease or other traces of dirt from the pipe or spigot ends of fittings to be welded and the welding area of the interior of the fitting or coupling. Use only isopropanol (Isopropyl Alcohol) and a soft clean wiping cotton cloth (note that for best results, use the purest form of Isopropyl Alcohol available, preferably 99% grade where available). Wait until the cleaned parts are completely dry.

Measure the insertion length of the pipe inside the fitting.



Mark the welding insertion depth on the pipe (equal to the length of the electrofusion fitting socket) using a sharpie. Note that unlike the marking step required for scraping, this mark should be exactly the length required for insertion and welding. The scraped marks should extend at least 3/8 inches past this mark.



Insert the pipe or spigot ends into the fitting up to the marked insertion length. In the case of welding parts that must be forced into alignment, or are substantially unsupported (including vertical risers), use an Niron alignment tool in order to maintain the position. Be sure to avoid any mechanical stress during the welding procedure and cooling time.



ATTENTION!

Avoid any mechanical stress on the welding area during the welding procedure and the cooling time.

IMPORTANT

Please refer to the user's manual of the welding machine for its correct use.



Prepare the pipe and fitting to be welded following the directions in the previous chapter. Make sure that the pipe and fitting to be welded are lined up without any possibility of movement (use a suitable aligner whenever it is possible or practical to do so).

Connect the welding cables to the fitting connectors, scan the barcode with the barcode scanner or enter the welding parameters manually.

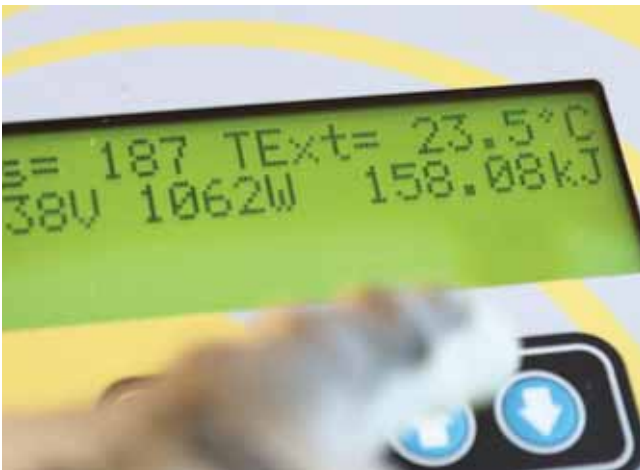

ATTENTION!

Always check the welding parameters before starting the welding procedure.



At the end of the welding procedure, disconnect the cables and wait for the cooling time indicated on the barcode. Prior to disconnecting the cables, note the weld number and mark the coupling or fitting with the last three digits of the machine serial number and the weld number. The welding data can be downloaded using a USB pen drive or instantly printed through a printer. The exact position of the joint can be recorded only for SMART models.

When the cooling time is over, remove any aligners that were used and start the pressure test by using the pressure test unit.

3.4 BUTT FUSION WELDING

3.4.1 INTRODUCTION

The butt welding process consists of the joining of two components (pipes and/or fittings) of equal diameter and thickness in which the surfaces to be welded are heated until melting by contact with a heating element and then, after its removal, are axially (butt) joined by welding with an applied force. Like Polyfusion and Electrofusion, with butt fusion welding there is no additional contribution or use of filler materials (i.e. welding rod or flux) required to complete the weld.

The instructions below are for guidance only. Unlike socket fusion, butt fusion welding implies that the operators are suitably trained on the use of specific welding machines to be used and have a thorough knowledge of the procedures to be performed. Training is machine-specific, as many details will vary based on specific machine used.

ATTENTION!

Each manufacturer of BUTT FUSION WELDING equipment publish his/her own reference literature based on the working parameters of the equipment produced. The user SHALL REFER to this specific literature for every detail not expressly stated and for any reference information regarding the equipment.

3.4.2 RECOMMENDATIONS AND WARNINGS

To perform a proper fusion procedure and ensure a reliable joint, it is necessary to remember the following steps:

- The working temperature of the heating element shall be checked using a calibrated contact thermometer. This measurement shall be done after about 10 minutes after the nominal temperature is reached, allowing the heating element to heat up evenly over the entire section.
- Check the surface of the heating element (integrity of the non-stick layer) and properly clean it by using soft paper or cloth, free of fibers.
- Check for the proper functioning of the welding machine.
- Check the clamp supports of the welding machine to make sure that the pieces to be welded are properly aligned and the surfaces touching each other are parallel.
- Check the drag force of the movable bed to be sure that it is free to move and that it can handle the load required to weld the pipes and/or fittings.
- Check the efficiency of the measuring equipment (pressure gauge and timer).
- Check that the pipes and/or fittings to be welded are of the same diameter and the same thickness (SDR).
- The planing tool provided with the welding machine shall plane and align the pipes and fittings to be welded and also absorb the pressures developed during the welding process without damaging the pipe and fitting ends.
- The welding machine should be prepared for use according to the manufacturer's instructions.

3.4.3 BUTT FUSION WELDING PROCEDURE

PREPARATION FOR WELDING

Cleaning the surfaces

Before positioning the parts to be welded, clean the welding area to remove any dust, grease or dirt.

Locking the ends

The pipes and/or fittings must be locked in the clamps of the welding machine so that the contact surfaces to be welded are aligned between them. The possibility of axial movement without significant friction shall be ensured by using rollers or oscillating suspensions to allow the pipe sliding to remove any mechanical stress from the clamps resulting from the weight of the locked pipes.

The pipes and/or fittings shall be positioned so as to contain the misalignment within 10%. To obtain this result, rotate at least one of the elements until the most favorable match-up of the pipe ends reached and/or the locking force exerted on the fastening systems of the clamps is not excessive as it could damage the surfaces of the components.

Planing (milling) the edges to be welded

The ends of the two components to be welded shall be planed to ensure adequate plane parallelism and to remove any trace of oxide.

The planing operation shall be carried out by bringing the parts close to each other only when the milling cutter inserted between them is working and by exerting gradual pressure such as not to stop the tool and prevent excessive heating of the surfaces in contact.

The planing chips must be formed continuously on both edges to be welded: otherwise, investigate the cause and repeat the process until the required result is reached.

The planer must be turned off only after the removal of the ends to be welded.





After the planing procedure is finished, planing chips shall be removed from the inner surface and the surrounding area of the elements to be welded, by using a brush or a clean cloth, free of fibers, fluff and lint and not synthetic, soaked in a suitable cleaning liquid (e.g. isopropyl alcohol, trichloroethane chloroethene). Do not use any solvent such as gasoline, denatured alcohol or trichlorethylene.

The planed surfaces shall not be touched or otherwise contaminated.

At the end of this phase, bring the two ends into contact, and check to see that the space between the two edges must not exceed the value of 0.02 inches (0.5 mm), a value that is half way between 1/64th of an inch and 1/32nd of an inch (which is difficult to measure, but can be estimated by checking using the width of a sheet of standard thin 20 pound paper). The value referenced above is slightly less than the thickness of standard 20 pound paper).

WELDING PROCEDURE

Welding procedure by means of contact heating elements

The butt fusion welding of pipes and/or fittings by means of contact heating elements shall be carried out following the different steps of the welding procedure shown in the Figure below.

In particular:

- Phase 1 : Approaching and preheating
- Phase 2 : Heating (410°F/210°C)
- Phase 3 : Removing the heating element
- Phase 4 : Reaching the welding pressure
- Phase 5 : Welding
- Phase 6 : Cooling

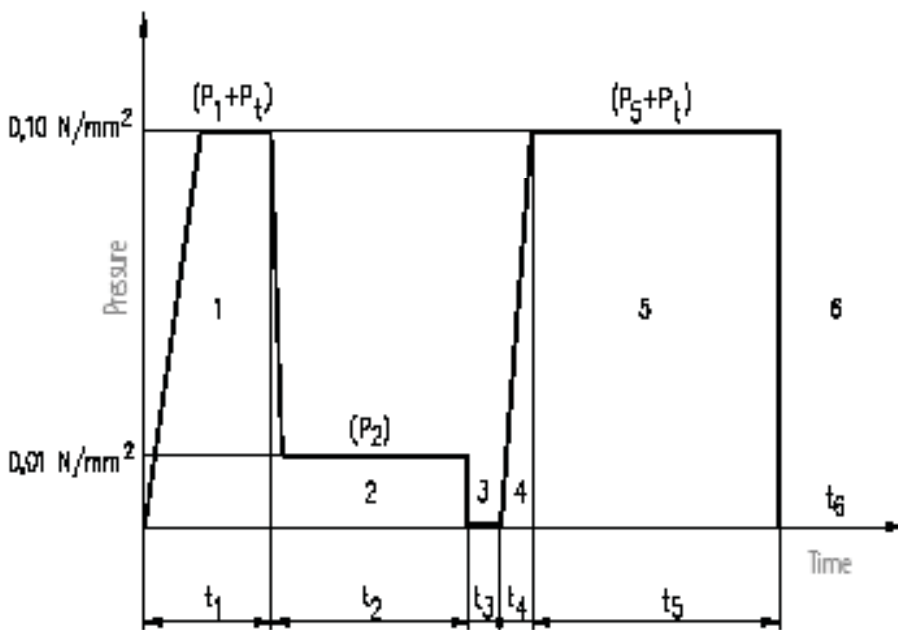

nd

- hase 1 : Approaching and preheating
- hase 2 : Heating (410°F/210°C)
- hase 3 : Removing the heating element
- hase 4 : Reaching the welding pressure
- hase 5 : Welding
- hase 6 : Cooling



WELDING PHASES

Phase 1: Approaching and preheating

Set the heating element to the welding temperature of 410°F (210°C). Once the heating element is up to temperature, place the heating element on the welding machine, taking care to insert it properly in order to ensure its stability on the supports of the machine base.

Place the edges close to the heating element and apply the initial welding force [pressure ($P_1 + P_t$)] for a time t_1 and wait until the bead has reached height h on both welding edges, as shown in Table 1 (pages 70, 71).

Phase 2: Heating

Once the bead has reached height initial bead size h , the contact pressure between the edges and the heating element is reduced to a low enough pressure to insure contact with the heating element during the heating phase.

Keep the parts in contact with the heating element for the time t_2 (Table 1).



Phase 3: Removing the heating element

Remove the heating element, making sure not to damage the edges of the two parts to be welded.

The removal must be rapid to avoid excessive cooling of the heated edges. The Changeover Time t_3 , is reported in seconds, is the amount of time from the removal of the heating element to the point where the two pipes come into contact with each other (phase 4). The maximum allowable changeover time varies according to diameter and wall thickness as shown in Table 1.



Phase 4: Reaching the welding pressure

Once the heating element has been removed, bring the edges into contact. Gradually increase pressure until the value $(P_5 + P_t)$ (phase 5) is reached so as to prevent excessive leakage of melted material from the edges in contact. Reaching the final welding force [welding pressure $(P_5 + P_t)$] must take the amount of time t_4 shown in Table 1.



Phase 5: Welding

Keep the edges in contact under pressure $(P_5 + P_t)$ for a time t_5 , expressed in minutes, as shown in table 1, unless the welding is performed in-line (e.g. on a pipe rack, on pipe hangers, performed on a vertical line, etc.) in which case the full welding time t_6 must be observed while the pipes are clamped.

Phase 6: Cooling

Once the welding time is over (phase 5), the welded joint can be removed from the welding machine, without being subjected to significant stress. Allow the welded joint to completely cool to ambient temperature.





3.4.4 BUTT FUSION WELDING PARAMETERS

TABLE 1: BUTT WELDING PARAMETERS FOR NIRON PP-RCT PIPING

SIZE OF PIPE	SDR	INITIAL WELDING FORCE LBS (*)	INITIAL BEAD SIZE INCHES, h	HEAT SOAK TIME SECONDS, t2	MAX CHANGE OVER TIME, t3 s	REACH FULL WELD PRESSURE, t4 s	WELDING FORCE LBS (*)	NORMAL COOLING TIME MINUTES, t5	IN-LINE COOLING TIME MINUTES, t6
2" (63 mm)	7.3	33	1/32	197	5	6	33	3.5	12
2½" (75 mm)	7.3	47	1/32	221	6	7	47	4.5	14
3" (90 mm)	7.3	68	1/32	249	7	11	68	5	20
4" (110 mm)	7.3	101	1/32	283	8	9	101	6.5	24
5" (125mm)	7.3	130	1/32	307	9	16	130	7.5	27
6" (160 mm)	7.3	214	1/16	359	10	19	214	9.5	34
8" (200 mm)	7.3	334	1/16 - 3/32	411	11	23	334	12	41
10" (250 mm)	7.3	522	1/16 - 3/32	460	13	27	522	15	51
12" (315 mm)	7.3	828	3/32	519	16	37	828	18	62
14" (355 mm)	7.3	1053	3/32	552	17	42	1053	21	69
2" (63 mm)	9	28	1/32	175	5	6	28	3	12
2½" (75 mm)	9	40	1/32	195	6	7	40	3.5	12
3" (90 mm)	9	56	1/32	217	7	9	56	4	14
4" (110 mm)	9	84	1/32	249	7	11	84	5	20
5" (125mm)	9	109	1/32	268	8	13	109	6	23
6" (160 mm)	9	179	1/32	315	9	16	179	7	28
8" (200 mm)	9	279	1/16	361	10	19	279	9	35
10" (250 mm)	9	436	1/16 - 3/32	413	11	23	436	12	42
12" (315 mm)	9	692	1/16 - 3/32	468	13	28	692	15	52
14" (355 mm)	9	880	3/32	497	14	34	880	17	58
2" (63 mm)	11	23	1/64	156	5	6	23	2.5	9
2½" (75 mm)	11	33	1/64	172	6	7	33	3	9
3" (90 mm)	11	47	1/32	192	6	8	47	3	9
4" (110 mm)	11	71	1/32	217	7	9	71	4	11
5" (125mm)	11	92	1/32	237	7	11	92	5	12
6" (160 mm)	11	149	1/32	277	8	13	149	6	24
8" (200 mm)	11	233	1/32	320	9	17	233	7	29
10" (250 mm)	11	365	1/16	366	10	19	365	9	35



TABLE 1: BUTT WELDING PARAMETERS FOR NIRON PP-RCT PIPING

SIZE OF PIPE	SDR	INITIAL WELDING FORCE LBS	INITIAL BEAD SIZE INCHES	HEAT SOAK TIME SECONDS, t2	MAX CHANGE OVER, t3 s	REACH WELD PRESSURE, t4 s	WELDING FORCE LBS	NORMAL COOLING TIME MINUTES, t5	IN-LINE COOLING TIME MINUTES, t6
12" (315 mm)	11	579	1/16 - 3/32	420	11	24	579	12	44
14" (355 mm)	11	736	1/16 - 3/32	447	12	27	736	14	48
16" (400 mm)	11	934	1/16 - 3/32	477	14	32	934	15	54
18" (450 mm)	11	1203	3/32	507	15	35	1203	17	60
20" (500 mm)	11	1460	3/32	533	16	38	1460	19	65
22" (560 mm)	11	1831	3/32 - 1/8	---	17	43	1831	22	71
24" (630 mm)	11	2316	3/32 - 1/8	---	18	45	2316	25	---
2" (63 mm)	17	16	1/64	108	5	6	16	1.5	5
2½" (75 mm)	17	22	1/64	129	5	6	22	2	6
3" (90 mm)	17	32	1/64	145	5	6	32	2	7
4" (110 mm)	17	47	1/64	164	6	7	47	2.5	10
5" (125mm)	17	59	1/32	176	6	7	59	3	10
6" (160 mm)	17	100	1/32	210	6	8	100	4	11
8" (200 mm)	17	156	1/32	204	7	11	156	5	20
10" (250 mm)	17	244	1/32	278	8	13	244	6	24
12" (315 mm)	17	388	1/32	324	9	17	388	8	29
14" (355 mm)	17	493	1/16	348	9	18	493	9	33
16" (400 mm)	17	626	1/16	377	11	20	626	10	37
18" (450 mm)	17	806	1/16 - 3/32	406	11	22	806	11	41
20" (500 mm)	17	978	1/16 - 3/32	426	11	24	978	12	45
22" (560 mm)	17	1227	1/16 - 3/32	453	12	27	1227	14	50
24" (630 mm)	17	1552	1/16 - 3/32	483	14	32	1552	16	55

(*) For pipe with "FG" layer the pressure must be increased of 0,85 ± 0,06 pound/inch.

- Note:
1. Butt Welding of Niron PP-RCT is to be performed at a heating element temp of 410°F ± 18°F.
 2. Cooling time represents the time the pipe and/or fittings must be held clamped in the machine under pressure after joining.
 3. When welding is performed in a bench type setting, normal cooling times can be observed. When welding is performed in place (e.g. up in the air or on pipe racks, then the full cooling time shown in the last column titled "In-Line Cooling" must be used.
 4. Inline refers to welding pipe while it is on hangers, on a pipe rack, or in a vertical position.
 5. In all cases, substantial pressure or bending stress must be avoided on the welded assembly until the full cooling time in the last column is observed.
 6. The information in the chart above is for manual butt fusion machines. When using a hydraulic machine, the welding pressure to be used (in place of the welding force) will depend on the specific machine used and the drag force required. This will vary by specific hydraulic machine type.

NIRON[®]

PP-RCT PIPING

SYSTEMS

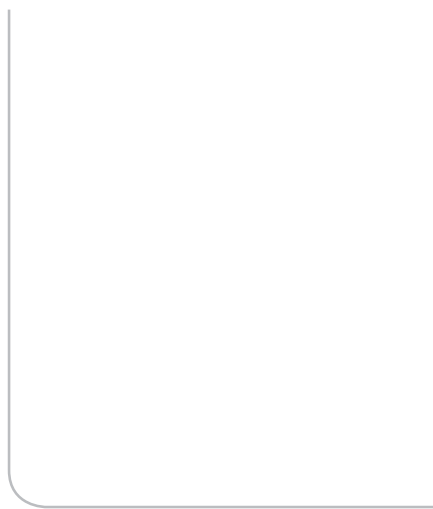



4

• TECHNICAL DATA

4.1 CHEMICAL, PHYSICAL AND MECHANICAL PROPERTIES (PP-RCT)

Characteristics	Test method	Values	Unit of measure
Volumic mass	ISO 1183	56.06	lb/ft ³
Yield strength	ISO 527	3,336	lb/in ²
Elongation at break	ISO 527	> 50	%
Modulus of elasticity	ISO 527	123,300	lb/in ²
Liquidity index MFI 190/5	ISO 1133 Procedure 18	0.011	lb/10 min
Heat conductivity (λ)	DIN 52612	1.7	BTU-in/hr-ft ² -°F
Linear thermal expansion coefficient	VDE 0304	8.33 x 10 ⁻⁵	F ⁻¹
Melting range	DIN 53736b2	302 - 309	°F
Impact strength (Charpy) +23°C	ISO 179/1 e A	no break	ft-lbs/in ²
-30°C	ISO 179/1 e A	23.8	ft-lbs/in ²
Volumic strength	IEC 93	> 6.0 x 10 ²²	circ mil Ω /ft
Dielectric strength	IEC 243/1	1.905	KV/mil
Fire resistance	DIN 4102	B2	

4.2 THE PIPE

NIRON PP-RCT pipes are manufactured in accordance with ASTM F2389, CSA B137.11, DIN 8077/8078 and European standard UNI EN- ISO15874 and are divided into:

- **SINGLE LAYER PIPES**
- **COMPOSITE PIPES**

They are sized to meet the needs of different types of installation.

The maximum constant pressure in bar at 20° C, is obtained by the relation:

$$PN = \frac{20 X \sigma}{SDR - 1}$$

where:

PN = Nominal Pressure (bar)

σ = Hydrostatic Design Stress

SDR = Standard Dimension Ratio (diameter/thickness ratio)

4.3 THERMAL EXPANSION

Plastic pipes, like all materials, are subject to thermal expansion and contraction upon experiencing a change in temperature. This phenomenon that has to be taken into consideration to prevent any possible damage to the piping system and again is true for all materials. The thermal expansion or contraction of a plastic pipe can be calculated using the formula and the coefficients of thermal expansion shown in the following table.

COEFFICIENT OF LINEAR THERMAL EXPANSION FOR PLASTIC PIPING

Pipe material	α
PE	1.11×10^{-5}
PE-X	8.33×10^{-5}
PP-RCT	8.33×10^{-5}
PP-RCT w/Fiberglass	1.94×10^{-5}

$$\Delta L = \alpha L \Delta t$$

Symbol	Description	Value	Unit of measure	
$\Delta L =$	linear thermal expansion		in	inches
$\alpha =$	Coefficient of linear thermal expansion of Niron Blue and Mono Grey	8.33×10^{-5}	in/in°F	in/in Fahrenheit
$\alpha(\text{FG}) =$	coefficient of linear thermal expansion of Niron Clima, Niron Clima Dark and Niron FG Red	1.94×10^{-5}	in/in°F	in/in Fahrenheit
L =	pipe length		in	inch
$\Delta T =$	difference of temperature between installation temp and transported fluid		°F	degrees Fahrenheit



LINEAR THERMAL EXPANSION FOR NIRON BLUE AND NIRON MONO GREY

$\Delta t = \text{fluid } T^\circ - \text{installation } T^\circ$

L (ft)	ΔL (inches)							
	20 F	40 F	60 F	80 F	100 F	120 F	140 F	160 F
1	0.0	0.0	0.1	0.1	0.1	0.1	0.1	0.2
5	0.1	0.2	0.3	0.4	0.5	0.6	0.7	0.8
10	0.2	0.4	0.6	0.8	1.0	1.2	1.4	1.6
15	0.3	0.6	0.9	1.2	1.5	1.8	2.1	2.4
20	0.4	0.8	1.2	1.6	2.0	2.4	2.8	3.2
25	0.5	1.0	1.5	2.0	2.5	3.0	3.5	4.0
30	0.6	1.2	1.8	2.4	3.0	3.6	4.2	4.8
35	0.7	1.4	2.1	2.8	3.5	4.2	4.9	5.6
40	0.8	1.6	2.4	3.2	4.0	4.8	5.6	6.4
45	0.9	1.8	2.7	3.6	4.5	5.4	6.3	7.2
50	1.0	2.0	3.0	4.0	5.0	6.0	7.0	8.0
60	1.2	2.4	3.6	4.8	6.0	7.2	8.4	9.6
70	1.4	2.8	4.2	5.6	7.0	8.4	9.8	11.2
80	1.6	3.2	4.8	6.4	8.0	9.6	11.2	12.8
90	1.8	3.6	5.4	7.2	9.0	10.8	12.6	14.4
100	2.0	4.0	6.0	8.0	10.0	12.0	14.0	16.0

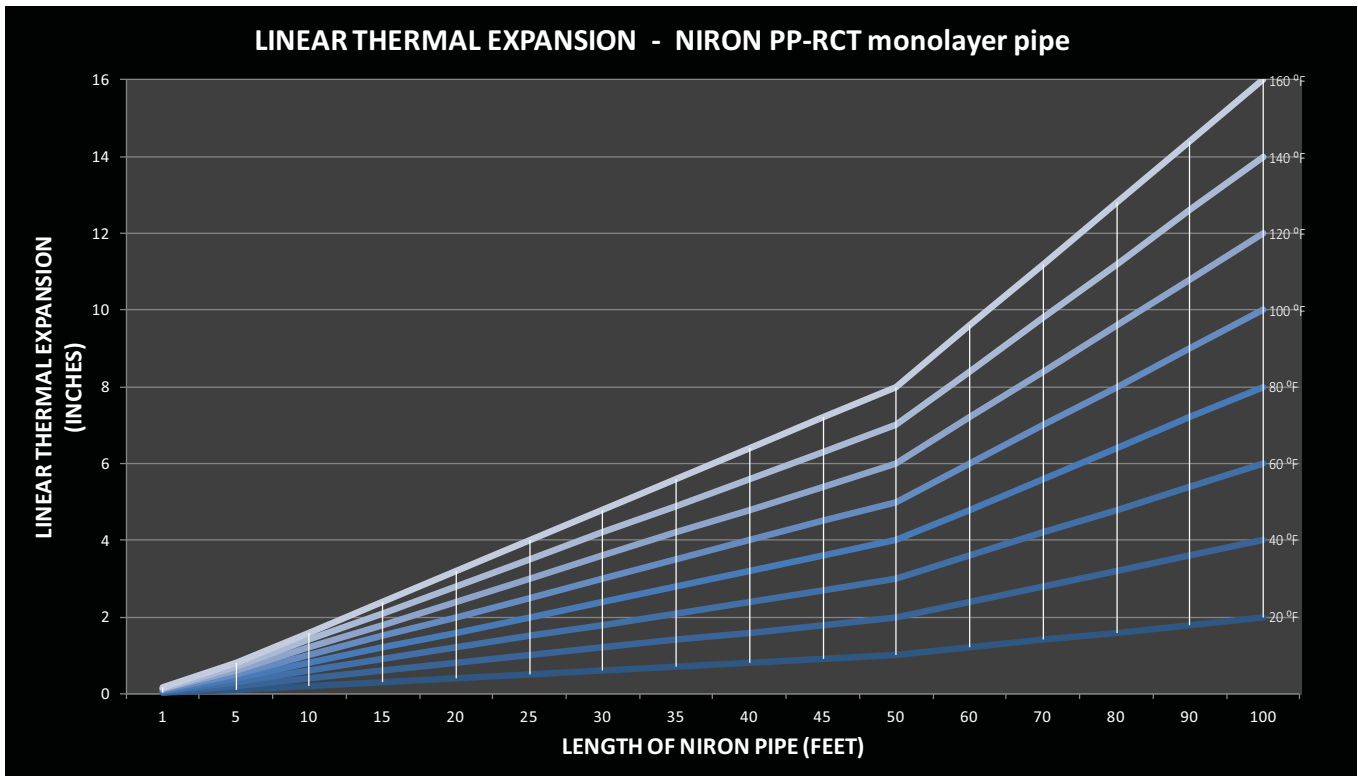

LINEAR THERMAL EXPANSION FOR NIRON CLIMA, CLIMA DARK AND FG RED

L (ft)	$\Delta t = \text{fluid } T^\circ - \text{installation } T^\circ$							
	20 F	40 F	60 F	80 F	100 F	120 F	140 F	160 F
	ΔL (inches)							
1	0.0	0.0	0.0	0.0	0.0	0.0	0.0	0.0
5	0.0	0.0	0.1	0.1	0.1	0.1	0.2	0.2
10	0.0	0.1	0.1	0.2	0.2	0.3	0.3	0.4
15	0.1	0.1	0.2	0.3	0.4	0.4	0.5	0.6
20	0.1	0.2	0.3	0.4	0.5	0.6	0.7	0.7
25	0.1	0.2	0.4	0.5	0.6	0.7	0.8	0.9
30	0.1	0.3	0.4	0.6	0.7	0.8	1.0	1.1
35	0.2	0.3	0.5	0.7	0.8	1.0	1.1	1.3
40	0.2	0.4	0.6	0.7	0.9	1.1	1.3	1.5
45	0.2	0.4	0.6	0.8	1.1	1.3	1.5	1.7
50	0.2	0.5	0.7	0.9	1.2	1.4	1.6	1.9
60	0.3	0.6	0.8	1.1	1.4	1.7	2.0	2.2
70	0.3	0.7	1.0	1.3	1.6	2.0	2.3	2.6
80	0.4	0.7	1.1	1.5	1.9	2.2	2.6	3.0
90	0.4	0.8	1.3	1.7	2.1	2.5	2.9	3.4
100	0.5	0.9	1.4	1.9	2.3	2.8	3.3	3.7

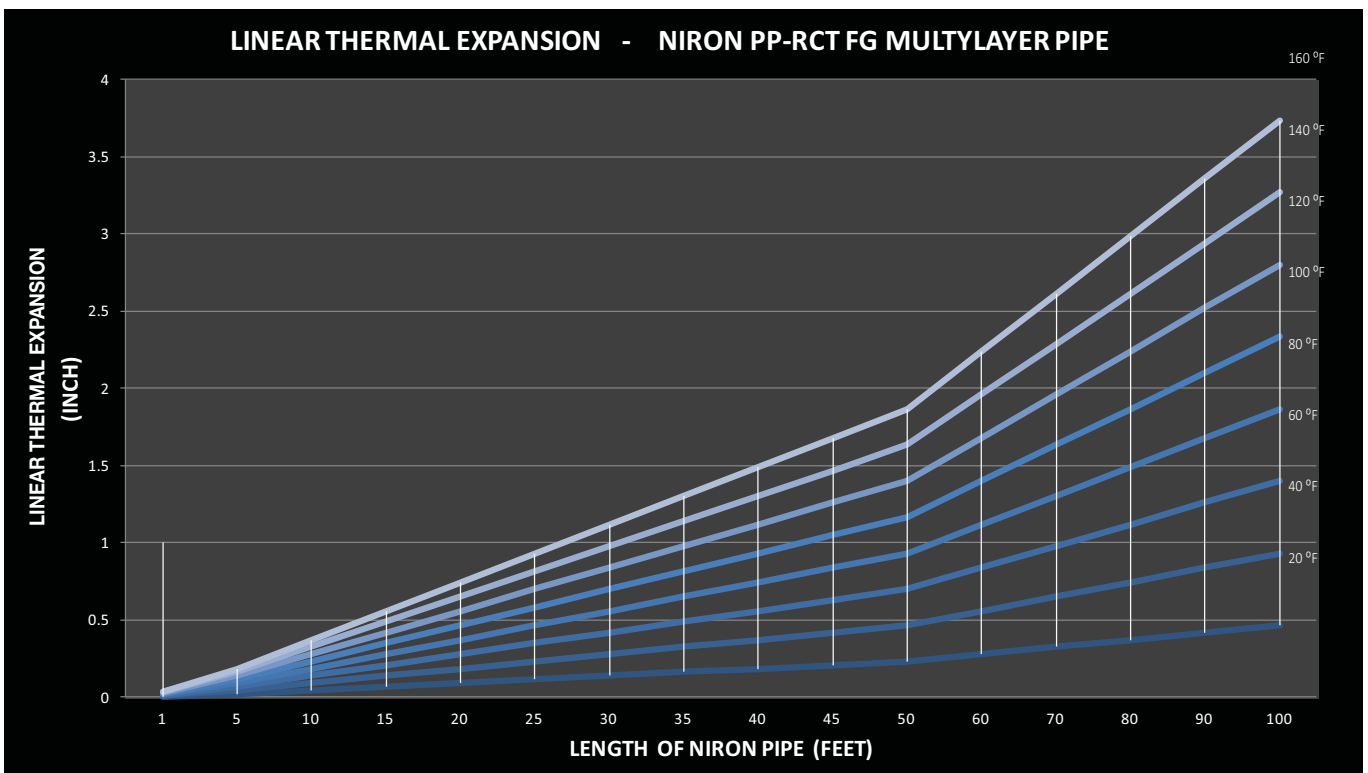

4.3.1 USE OF THERMAL EXPANSION ALLEVIATION METHODS (UNI EN 806-4)

Pipes can be laid on a continuous horizontal support (rails), where the elongation is compensated by the pipe snaking. The pipe trail should be designed so as to leave enough space for the elongation or contraction of the pipe. It is advisable to secure the pipe to avoid its vertical movement.

POSITIONING OF ANCHOR POINTS

The positioning of anchor points can be used to give direction to and to limit the amount of thermal expansion. Examples are given in Figures B.1, B.2 and B.3.

This is also valid for mains in a basement.

FIGURE B.1 - POSITIONING OF ANCHOR POINTS (INSTALLATION WITH BRANCHES)

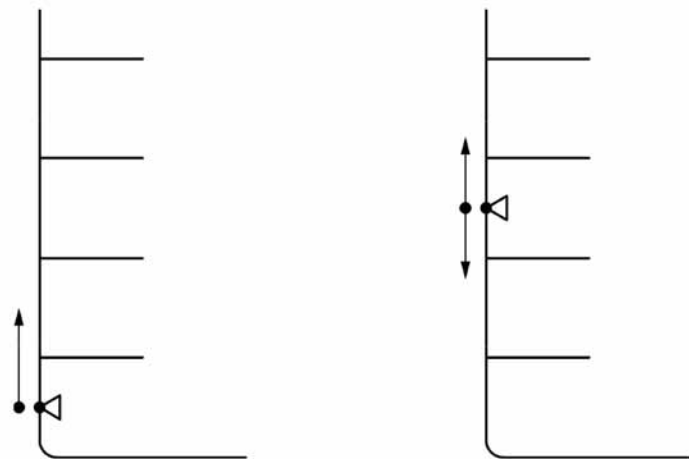

INSTALLATION OF PIPES ALLOWING EXPANSION BY MEANS OF A FLEXIBLE ARM

The flexible arm should be sufficiently long to prevent any damage. The brackets should allow clearance to the wall after expansion. This is also applicable in cases where pipes are supported along their length. A typical installation is shown in Figures B.2 and B.3.

FIGURE B.2 - COMPENSATION OF EXPANSION ΔL BY FLEXIBLE ARM

Key

- ΔL Length difference
- L Length of pipe section
- L_B Length of flexible arm
- \circ Anchor point

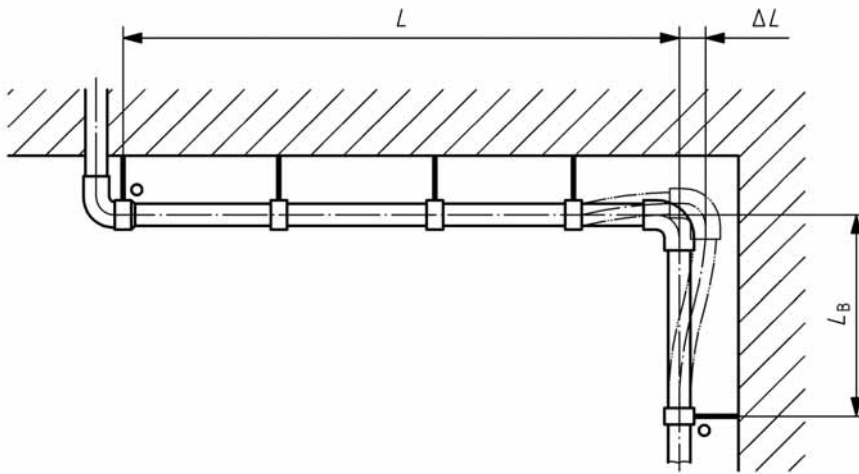
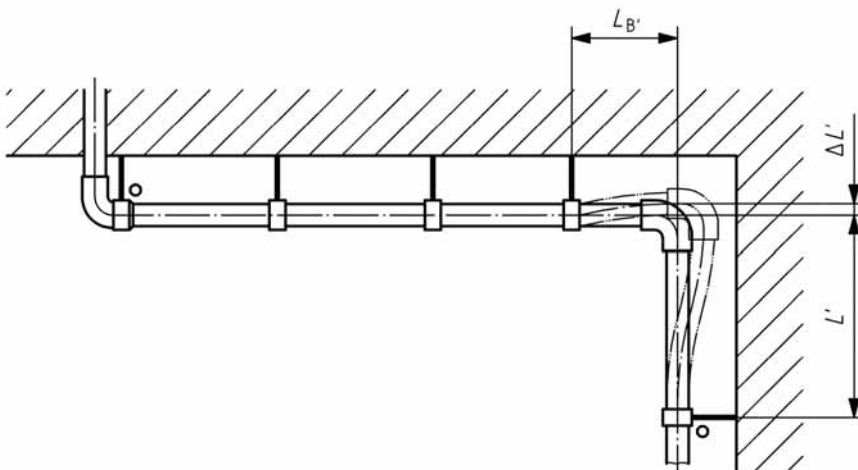

FIGURE B.3 - COMPENSATION OF EXPANSION ΔL BY FLEXIBLE ARM

Key

- $\Delta L'$ Length difference
- L' Length of pipe section
- L'_B Length of flexible arm
- \circ Anchor point



The length of the flexible arm, L_B can be calculated from the formula B.2 below:

$$L_B = C \times \sqrt{d_e \times \Delta L}$$

where

L_B is the length of the flexible arm, in inches;

C is the material constant in accordance with Table B.4;

d_e is the outside diameter, in inches;

ΔL is the thermal length variation as determined by formula B.1, in inches.

TABLE B.4 - VALUES OF MATERIAL CONSTANT C

Material	C
PE	27
PE-X	12
PP	20
PB	10
PE-RT	14

INSTALLATION ALLOWING EXPANSION BY MEANS OF AN EXPANSION LOOP

A typical installation is shown in Figure B.4.

FIGURE B.4 - COMPENSATION OF THE THERMAL EXPANSION BY EXPANSION LOOP

Key

See explanations to formula (B.3).

L Distance between fixed brackets

l_1 Length of loop

l_2 Width of loop

ΔL Linear thermal expansion

o Anchor point

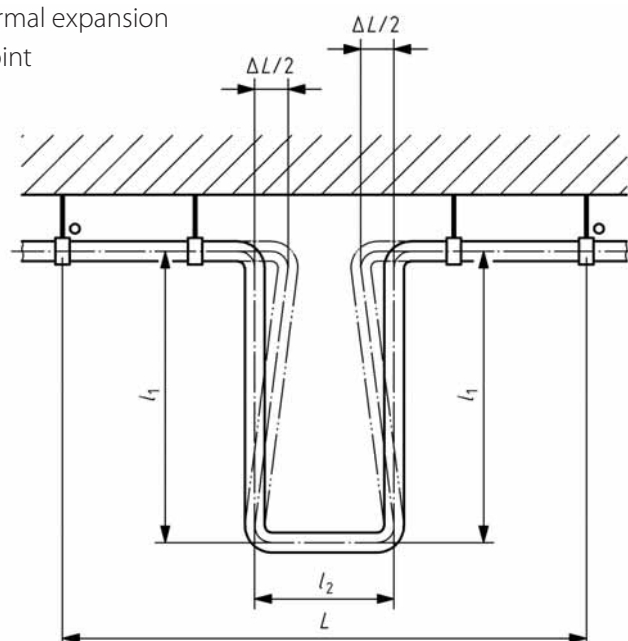

The length of the flexible arm, L_1 , can be calculated from the formula B.2 below:

$$L_1 = C \times \sqrt{d_e \times \Delta L}$$

where

L_1 is the length of the flexible arm, in inches;

C is the material constant = 20;

d_e is the outside diameter, in inches;

ΔL linear thermal expansion based on $L/2$, in inches;

l_2 is the width of loop, in inches, usually = at least 0.5 time L .

4.3.2 ABOVE GROUND SUPPORT OF NIRON PIPES

The support spacing of above ground Niron PP-RCT Piping systems depends on the type of pipe installed, the diameter and wall thickness and the maximum temperature expected during any time when the pipe is in service. The support spacing of the piping system should always be based on the maximum temperature to be encountered at any time, including situations where the external temperature surrounding the piping is greater than the highest expected fluid temperature.

The charts on the following two pages show the recommended support spacing for Niron Pipes in various classes of service. Note that the monolayer pipes (Niron Blue and Niron Mono Grey) are not shown with a temperature matrix, as they should only be used for ambient temperature service (i.e. 60°F to 100°F). For installations at temperatures above this for monolayer pipes, please consult the factory for support spacing recommendations.

Niron PP-RCT can also be supported with the use of galvanized steel half shields, which can provide extended support spacing to the piping. Please consult the factory for detailed recommendations when using these devices to extend the support spacing for Niron pipes.

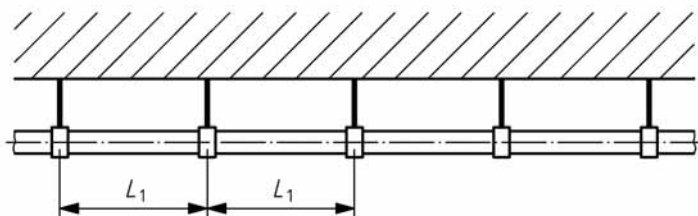



4.3.3 SUPPORT SPACING FOR NIRON PP-RCT PIPE

RECOMMENDED SUPPORT SPACING FOR NIRON FG RED/NIRON CLIMA SDR 7.3 PIPING

Design temp	½" 20	¾" 25	1" 32	1¼" 40	1½" 50	2" 63	2½" 75	3" 90	4" 110	5" 125	6" 160	8" 200	10" 250	12" 315
70°F	4	4.5	5	6	6.5	7.5	8	8	9	10	10	10	10	12
80°F	4	4	4.5	5.5	6	7	7	7.5	8	9	9.5	9.5	9.5	11
90°F	4	4	4	5	5.5	6.5	6.5	7	7.5	8.5	9	9	9.5	10
100°F	4	4	4	4.5	5	6	6	6.5	7	8	9	9	9	10
110°F	4	4	4	4.5	5	5.5	6	6.5	7	7.5	8	8	8.5	9
120°F	4	4	4	4	5	5.5	6	6	7	7.5	8	8	8	9
130°F	4	4	4	4	5	5.5	5.5	6	6.5	7	7.5	7.5	8	8.5
140°F	4	4	4	4	4.5	5.5	5.5	6	6.5	7	7.5	7.5	8	8.5
150°F	4	4	4	4	4.5	5	5.5	6	6	6.5	7	6.5	7	7.5
160°F	4	4	4	4	4.5	5	5.5	6	6	6	6.5	6.5	7	7.5
170°F	4	4	4	4	4.5	5	5	5.5	5.5	6	6	6.5	6.5	7
180°F	4	4	4	4	4	5	5	5.5	5.5	6	6	6.5	6.5	7
190°F	4	4	4	4	4	4.5	5	5	5.5	6	6	6	6	6.5
200°F	4	4	4	4	4	4.5	5	5	5	5.5	6	6	6	6.5

RECOMMENDED SUPPORT SPACING FOR NIRON FG RED/NIRON CLIMA SDR 11 PIPING

Design temp	½" 20	¾" 25	1" 32	1¼" 40	1½" 50	2" 63	2½" 75	3" 90	4" 110	5" 125	6" 160	8" 200	10" 250	12" 315
70°F	4	4.5	5	6	6.5	7.5	8	8	9	10	10	10	10	12
80°F	4	4	4.5	5.5	6	7	7	7.5	8	9	9.5	9.5	9.5	11
90°F	4	4	4	5	5.5	6.5	6.5	7	7.5	8.5	9	9	9.5	10
100°F	4	4	4	4.5	5	6	6	6.5	7	8	9	9	9	10
110°F	4	4	4	4.5	5	5.5	6	6.5	7	7.5	8	8	8.5	9
120°F	4	4	4	4	5	5.5	6	6	7	7.5	8	8	8	9
130°F	4	4	4	4	5	5.5	5.5	6	6.5	7	7.5	7.5	8	8.5
140°F	4	4	4	4	4.5	5.5	5.5	6	6.5	7	7.5	7.5	8	8.5
150°F	4	4	4	4	4.5	5	5.5	6	6	6.5	7	6.5	7	7.5
160°F	4	4	4	4	4.5	5	5.5	6	6	6	6.5	6.5	7	7.5
170°F	4	4	4	4	4.5	5	5	5.5	5.5	6	6	6.5	6.5	7
180°F	4	4	4	4	4	5	5	5.5	5.5	6	6	6.5	6.5	7
190°F	4	4	4	4	4	4.5	5	5	5.5	6	6	6	6	6.5
200°F	4	4	4	4	4	4.5	5	5	5	5.5	6	6	6	6.5

RECOMMENDED SUPPORT SPACING FOR NIRON CLIMA SDR 17 PIPING

Design temp	2" 63	2½" 75	3" 90	4" 110	5" 125	6" 160	8" 200	10" 250	12" 315	14" 355	16" 400	18" 450	20" 500	22" 560	24" 630
70°F	6	6.5	6.5	7	8	8	8.5	9	9	9	9.5	10	10	10.5	10.5
80°F	5.5	5.5	6	6.5	7	7	7.5	9.5	8	8.5	8.5	9	9.5	10	10
90°F	5	5	5.5	6	6.5	6.5	7	7	7.5	8	8	8.5	9	9.5	9.5
100°F	5	5	5	5.5	6	6	6.5	6.5	7	7	7.5	8	8.5	9	9
110°F	5	5	5	5.5	5.5	6	6	8.5	6.5	6.5	7	7.5	8	8.5	9
120°F	4.5	5	5	5.5	5.5	6	6	8	6.5	6.5	7	7.5	8	8.5	9
130°F	4.5	4.5	5	5	5.5	5.5	6	8	6	6	6.5	7	7.5	8	8.5
140°F	4.5	4.5	4.5	5	5.5	5.5	6	8	6	6	6.5	7	7.5	8	8.5
150°F	4	4.5	4.5	4.5	5	5	6	7	6	6	6.5	7	7.5	8	8
160°F	4	4.5	4.5	4.5	5	5	6	7	6	6	6.5	7	7.5	8	8
170°F	4	4	4.5	4.5	5	5	5.5	5.5	5.5	5.5	6	6.5	7	7.5	7.5
180°F	4	4	4	4.5	4.5	5	5.5	5.5	5.5	5.5	6	6.5	7	7.5	7.5
190°F	3.5	4	4	4	4.5	4.5	5	5	5.5	5.5	5.5	6	6.5	7	7.5
200°F	3.5	4	4	4	4.5	4.5	5	5	5.5	5.5	5.5	6	6.5	7	7.5

RECOMMENDED SUPPORT SPACING FOR NIRON BLUE/NIRON MONO GREY SDR 11 PIPING

T	½" 20	¾" 25	1" 32	1¼" 40	1½" 50	2" 63	2½" 75	3" 90	4" 110	5" 125	6" 160	8" 200	10" 250	12" 315	14" 355	16" 400	18" 450	20" 500	22" 560	24" 630
70°F	4	4	4	4	4	4.5	5	5	5.5	6.5	7	7.5	7.5	8	9.5	10.5	11	12	12	13.5

RECOMMENDED SUPPORT SPACING FOR NIRON BLUE/NIRON MONO GREY SDR 17 PIPING

T	½" 20	¾" 25	1" 32	1¼" 40	1½" 50	2" 63	2½" 75	3" 90	4" 110	5" 125	6" 160	8" 200	10" 250	12" 315	14" 355	16" 400	18" 450	20" 500	22" 560	24" 630
70°F	-	-	-	-	-	4	4	4	4.5	5	5.5	6	6	6.5	7.5	8.5	9	10	10	10

Notes for Support Spacing: Support spacing for Niron PP-RCT pipes, as with all plastic piping, will vary according to the design temperature of the piping system, as well as due to any thermal expansion of the piping that might occur from installation temperature. The design temperature of the piping is either the maximum fluid temperature expected during operation or testing, or the ambient temperature surrounding the piping, whichever is greater. If the ambient temperature at installation is lower than the final temperature during building start-up and normal operation then thermal expansion will occur in the Niron Piping (this will occur if the installation is performed in an unheated building during winter conditions). To account for and control the potential bending and twisting of the pipes between supports, add the net difference between 70°F and the expected low installation temperature to the design temperature. This will result in an increase in the design temperature. As an example, if the installation temperature is 40°F and the design temperature is 120°F, add 70°F – 40°F = 30°F to the design temperature of 120°F, to equal 30°F + 120°F = 150°F. The support spacing in this example should be based on 150°F.

N.B.:

Please contact NUPI AMERICAS Technical Office for heat loss values according to different water velocities, pipe SDR, thermal conductivity of the insulation layer and ambient temperatures.

4.4 HEAT LOSS

Many places require that the hot water temperature at the point of use is maintained at a certain level and requires the insulation of all piping. The thickness of the insulation layer depends on its thermal conductivity and the pipe diameter. NIRON pipes, both insulated and non-insulated, have very low heat loss which allows NIRON to meet the required values in most jurisdictions. The following tables provide insulation guidelines for hot water systems that allow NIRON to maintain water minimum required water temperatures at the point of use in most jurisdictions.

HEAT LOSS NIRON PIPE (BARE AND INSULATED)
Water Temp. 120°F – Ambient Temp. 70°F (DT = 50°F)

Nom Ø	SDR	Insulation Thickness (in.)		
		0	0.5	1
Heat loss (Btu/h ft.)				
1/2	7.4	30.79	7.80	5.41
3/4	7.4	36.52	8.99	6.11
1	7.4	43.92	10.62	7.07
1-1/4	7.4	51.06	12.40	8.11
1-1/2	7.4	58.61	14.54	9.36
2	7.4	67.25	17.24	10.95
2-1/2	7.4	73.40	19.59	12.36
3	7.4	80.31	22.44	14.08
3-1/2	7.4	87.29	25.59	16.28
4	7.4	91.97	28.56	17.89
6	7.4	100.16	34.10	21.46
8	7.4	106.90	39.82	25.30
10	7.4	113.22	46.23	29.78
12	7.4	118.86	53.48	35.12
14	7.4	121.67	57.48	38.19
16	7.4	124.00	61.53	41.42

HEAT LOSS NIRON PIPE (BARE AND INSULATED)
Water Temp. 120°F – Ambient Temp. 70°F (DT = 50°F)

Nom Ø	SDR	Insulation Thickness (in.)		
		0	0.5	1
Heat loss (Btu/h ft.)				
1	11	49.54	10.92	7.20
1-1/4	11	58.49	12.80	8.28
1-1/2	11	68.87	15.10	9.59
2	11	80.52	18.00	11.26
2-1/2	11	90.48	20.63	12.77
3	11	100.59	23.78	14.60
3-1/2	11	112.35	27.84	16.98
4	11	119.63	30.77	18.73
6	11	133.88	37.30	22.68
8	11	146.65	44.29	27.03
10	11	158.77	52.36	32.21
12	11	170.15	61.86	38.56
14	11	175.74	67.25	42.27
16	11	180.80	72.90	46.27
18	11	185.30	78.71	50.52

HEAT LOSS NIRON PIPE (BARE AND INSULATED)
Water Temp. 120°F – Ambient Temp. 70°F (DT = 50°F)

Nom Ø	SDR	Insulation Thickness (in.)		
		0	0.5	1
Heat loss (Btu/h ft.)				
1	9	46.83	10.78	7.19
1-1/4	9	55.05	12.63	8.26
1-1/2	9	64.15	14.86	9.57
2	9	73.95	17.65	11.20
2-1/2	9	82.04	20.16	12.68
4	9	105.61	29.76	18.50
6	9	116.69	35.83	22.32

Nom Ø	SDR	Insulation Thickness (in.)		
		0	0.5	1
Heat loss (Btu/h ft.)				
6	17	170.25	39.7	23.7
8	17	190.76	47.6	28.5
10	17	211.96	57.1	34.2
12	17	232.30	68.5	41.4
14	17	242.37	75.2	45.7
16	17	252.83	82.4	50.4
18	17	261.94	89.9	55.4
20	17	269.72	97.0	60.2
22	17	278.34	105.2	65.9
24	17	286.10	114.0	72.2

4.5 MINIMUM INSULATION TO PREVENT SWEATING IN AIR CONDITIONING SYSTEMS

The tables below indicate the minimum thickness of insulation required for NIRON pipes to avoid that moisture in the air condenses into dew on the pipes in air conditioning systems.

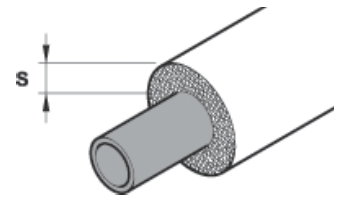

s = Minimum Insulation Thickness Required (inches) based on thermal conductivity of 0.263 BTU-in/hr-ft²-°F

T_e = External air temperature in °F

T_i = Temperature of the water inside the pipe in °F

60/80 = Relative humidity of the external air in %

SDR 7.3											
PIPE Ø 1/2" SDR 7.3											
T _i	T _e	79	81	82	84	86	88	90	91	93	humidity%
41	0.15	0.16	0.17	0.18	0.19	0.20	0.20	0.21	0.22	60	
	0.13	0.13	0.15	0.15	0.17	0.17	0.18	0.19	0.20		
	0.10	0.11	0.12	0.13	0.14	0.15	0.16	0.17	0.18		
45	0.42	0.43	0.45	0.46	0.48	0.50	0.51	0.53	0.54	80	
	0.37	0.39	0.41	0.43	0.44	0.46	0.47	0.49	0.50		
	0.33	0.35	0.37	0.38	0.40	0.41	0.43	0.44	0.47		

SDR 7.3											
PIPE Ø 3/4" SDR 7.3											
T _i	T _e	79	81	82	84	86	88	90	91	93	humidity%
41	0.15	0.16	0.17	0.18	0.19	0.20	0.20	0.21	0.22	60	
	0.12	0.13	0.15	0.15	0.17	0.18	0.19	0.20	0.20		
	0.10	0.11	0.12	0.13	0.14	0.15	0.16	0.17	0.18		
45	0.43	0.44	0.46	0.48	0.49	0.51	0.52	0.54	0.56	80	
	0.39	0.40	0.42	0.44	0.46	0.47	0.49	0.51	0.53		
	0.34	0.36	0.38	0.40	0.41	0.43	0.45	0.47	0.48		

SDR 7.3											
PIPE Ø 1" SDR 7.3											
T _i	T _e	79	81	82	84	86	88	90	91	93	humidity%
41	0.15	0.16	0.17	0.18	0.19	0.20	0.20	0.21	0.22	60	
	0.12	0.13	0.14	0.15	0.16	0.17	0.18	0.19	0.20		
	0.09	0.11	0.12	0.13	0.14	0.15	0.16	0.17	0.18		
45	0.44	0.46	0.48	0.50	0.52	0.53	0.55	0.57	0.59	80	
	0.40	0.42	0.44	0.45	0.47	0.49	0.51	0.53	0.54		
	0.35	0.37	0.39	0.41	0.43	0.45	0.47	0.49	0.51		

SDR 7.3											
PIPE Ø 1-1/4" SDR 7.3											
T _i	T _e	79	81	82	84	86	88	90	91	93	humidity%
41	0.15	0.16	0.17	0.18	0.19	0.19	0.20	0.21	0.22	60	
	0.12	0.13	0.14	0.15	0.16	0.17	0.18	0.19	0.20		
	0.09	0.11	0.12	0.12	0.14	0.15	0.16	0.17	0.18		
45	0.45	0.47	0.49	0.51	0.53	0.55	0.56	0.58	0.60	80	
	0.40	0.43	0.44	0.46	0.48	0.50	0.52	0.54	0.56		
	0.35	0.37	0.39	0.41	0.43	0.45	0.47	0.49	0.51		

SDR 7.3											
PIPE Ø 1-1/2" SDR 7.3											
T _i	T _e	79	81	82	84	86	88	90	91	93	humidity%
41	0.13	0.15	0.16	0.17	0.18	0.19	0.20	0.21	0.22	60	
	0.11	0.12	0.13	0.14	0.15	0.16	0.17	0.18	0.19		
	0.08	0.09	0.10	0.11	0.12	0.14	0.15	0.16	0.17		
45	0.46	0.48	0.50	0.52	0.54	0.56	0.58	0.60	0.62	80	
	0.41	0.43	0.45	0.47	0.49	0.51	0.53	0.55	0.57		
	0.35	0.38	0.40	0.42	0.44	0.46	0.48	0.50	0.52		

SDR 7.3											
PIPE Ø 2" SDR 7.3											
T _i	T _e	79	81	82	84	86	88	90	91	93	humidity%
41	0.13	0.14	0.15	0.16	0.17	0.18	0.19	0.20	0.21	60	
	0.10	0.11	0.12	0.13	0.14	0.16	0.17	0.18	0.19		
	0.07	0.08	0.09	0.10	0.11	0.13	0.14	0.15	0.16		
45	0.46	0.48	0.50	0.52	0.54	0.56	0.58	0.60	0.62	80	
	0.41	0.43	0.45	0.47	0.50	0.52	0.54	0.56	0.58		
	0.35	0.38	0.40	0.42	0.44	0.46	0.49	0.51	0.53		

SDR 7.3											
PIPE Ø 2 1/2" SDR 7.3											
T _i	T _e	79	81	82	84	86	88	90	91	93	humidity%
41	0.11	0.12	0.13	0.15	0.16	0.17	0.18	0.19	0.20	60	
	0.08	0.09	0.11	0.12	0.13	0.14	0.15	0.16	0.17		
	0.05	0.06	0.07	0.09	0.10	0.11	0.13	0.14	0.15		
45	0.46	0.48	0.50	0.52	0.54	0.56	0.58	0.60	0.62	80	
	0.40	0.42	0.44	0.46	0.48	0.51	0.53	0.55	0.57		
	0.35	0.37	0.39	0.41	0.44	0.46	0.48	0.50	0.52		

SDR 7.3											
PIPE Ø 3" SDR 7.3											
T _i	T _e	79	81	82	84	86	88	90	91	93	humidity%
41	0.10	0.11	0.12	0.13	0.15	0.16	0.17	0.18	0.19	60	
	0.07	0.08	0.09	0.11	0.12	0.13	0.14	0.15	0.16		
	0.04	0.05	0.06	0.07	0.09	0.10	0.11	0.12	0.13		
45	0.45	0.47	0.50	0.52	0.54	0.56	0.58	0.60	0.62	80	
	0.39	0.42	0.44	0.46	0.48	0.50	0.53	0.55	0.57		
	0.33	0.36	0.38	0.41	0.43	0.45	0.47	0.50	0.52		

SDR 7.3											
PIPE Ø 4" SDR 7.3											
T _i	T _e	79	81	82	84	86	88	90	91	93	humidity%
41	0.09	0.10	0.11	0.13	0.14	0.15	0.16	0.17	0.18	60	
	0.06	0.07	0.09	0.10	0.11	0.12	0.13	0.15	0.16		
	0.03	0.04	0.06	0.07	0.08	0.09	0.11	0.12	0.13		
45	0.45	0.48	0.50	0.53	0.55	0.57	0.59	0.61	0.64	80	
	0.39	0.42	0.44	0.47	0.49	0.52	0.54	0.56	0.58		
	0.33	0.36	0.39	0.41	0.44	0.46	0.48	0.51	0.53		

SDR 7.3											
PIPE Ø 5" SDR 7.3											
T _i	T _e	79	81	82	84	86	88	90	91	93	humidity%
41	0.07	0.08	0.09	0.10	0.11	0.13	0.14	0.15	0.16	60	
	0.04	0.05	0.06	0.07	0.09	0.10	0.11	0.12	0.13		
	0.00	0.02	0.03	0.04	0.06	0.07	0.08	0.09	0.10		
45	0.43	0.46	0.48	0.51	0.53	0.55	0.58	0.60	0.62	80	
	0.37	0.40	0.43	0.45	0.47	0.50	0.52	0.54	0.57		
	0.31	0.34	0.37	0.39	0.42	0.44	0.46	0.49	0.51		

PIPE Ø 6" SDR 7.3

T _e T _i	79	81	82	84	86	88	90	91	93	humidity%
41	0.03	0.04	0.06	0.07	0.08	0.09	0.10	0.11	0.13	60
45	0.00	0.01	0.02	0.04	0.05	0.06	0.07	0.08	0.09	
48	0.00	0.00	0.00	0.01	0.02	0.03	0.04	0.06	0.07	
41	0.41	0.44	0.46	0.48	0.51	0.53	0.56	0.58	0.60	80
45	0.35	0.37	0.40	0.42	0.44	0.47	0.49	0.52	0.54	
48	0.28	0.31	0.33	0.36	0.39	0.41	0.44	0.46	0.49	

SDR 11

PIPE Ø 1" SDR 11

T _e T _i	79	81	82	84	86	88	90	91	93	humidity%
41	0.16	0.17	0.18	0.19	0.20	0.21	0.22	0.22	0.23	60
45	0.13	0.15	0.15	0.17	0.18	0.19	0.20	0.20	0.22	
48	0.11	0.12	0.13	0.14	0.15	0.17	0.18	0.19	0.20	
41	0.46	0.48	0.50	0.52	0.53	0.55	0.57	0.58	0.60	80
45	0.41	0.43	0.45	0.47	0.48	0.50	0.52	0.54	0.56	
48	0.36	0.38	0.40	0.42	0.44	0.45	0.47	0.49	0.52	

PIPE Ø 1-1/4" SDR 11

T _e T _i	79	81	82	84	86	88	90	91	93	humidity%
41	0.16	0.17	0.18	0.19	0.20	0.21	0.22	0.23	0.24	60
45	0.13	0.14	0.15	0.16	0.17	0.18	0.20	0.20	0.22	
48	0.10	0.11	0.13	0.14	0.15	0.16	0.17	0.18	0.19	
41	0.47	0.49	0.51	0.53	0.55	0.57	0.59	0.61	0.63	80
45	0.42	0.44	0.46	0.48	0.50	0.52	0.54	0.56	0.58	
48	0.37	0.39	0.41	0.43	0.45	0.47	0.49	0.51	0.53	

PIPE Ø 1-1/2" SDR 11

T _e T _i	79	81	82	84	86	88	90	91	93	humidity%
41	0.15	0.17	0.18	0.19	0.20	0.21	0.22	0.23	0.24	60
45	0.13	0.14	0.15	0.16	0.17	0.18	0.19	0.20	0.21	
48	0.10	0.11	0.12	0.13	0.15	0.16	0.17	0.18	0.19	
41	0.48	0.50	0.52	0.54	0.56	0.58	0.60	0.62	0.64	80
45	0.43	0.45	0.47	0.49	0.51	0.53	0.55	0.57	0.59	
48	0.37	0.40	0.42	0.44	0.46	0.48	0.50	0.52	0.54	

PIPE Ø 2" SDR 11

T _e T _i	79	81	82	84	86	88	90	91	93	humidity%
41	0.15	0.16	0.17	0.19	0.20	0.20	0.22	0.22	0.24	60
45	0.12	0.13	0.14	0.15	0.17	0.17	0.19	0.20	0.21	
48	0.09	0.11	0.11	0.13	0.14	0.15	0.16	0.17	0.19	
41	0.48	0.50	0.52	0.54	0.56	0.58	0.60	0.62	0.64	80
45	0.43	0.45	0.48	0.50	0.52	0.54	0.56	0.58	0.60	
48	0.38	0.40	0.42	0.44	0.46	0.48	0.50	0.52	0.55	

PIPE Ø 2-1/2" SDR 11

T _e T _i	79	81	82	84	86	88	90	91	93	humidity%
41	0.14	0.15	0.17	0.18	0.19	0.20	0.21	0.22	0.23	60
45	0.11	0.13	0.14	0.15	0.16	0.18	0.19	0.20	0.20	
48	0.08	0.10	0.11	0.12	0.13	0.14	0.15	0.17	0.18	
41	0.49	0.51	0.54	0.56	0.58	0.60	0.62	0.64	0.66	80
45	0.44	0.46	0.48	0.51	0.53	0.55	0.57	0.59	0.61	
48	0.38	0.41	0.43	0.45	0.48	0.50	0.52	0.54	0.56	

PIPE Ø 3" SDR 11

T _e T _i	79	81	82	84	86	88	90	91	93	humidity%
41	0.13	0.15	0.16	0.17	0.18	0.19	0.20	0.21	0.22	60
45	0.11	0.12	0.13	0.14	0.15	0.17	0.18	0.19	0.20	
48	0.07	0.09	0.10	0.11	0.12	0.13	0.15	0.16	0.17	
41	0.49	0.51	0.54	0.56	0.58	0.60	0.62	0.64	0.66	80
45	0.43	0.45	0.48	0.50	0.52	0.54	0.56	0.59	0.61	
48	0.37	0.40	0.43	0.45	0.47	0.49	0.51	0.53	0.56	

PIPE Ø 4" SDR 11

T _e T _i	79	81	82	84	86	88	90	91	93	humidity%
41	0.12	0.13	0.15	0.16	0.17	0.18	0.19	0.20	0.22	60
45	0.09	0.11	0.12	0.13	0.14	0.15	0.17	0.18	0.19	
48	0.06	0.07	0.09	0.10	0.11	0.12	0.13	0.15	0.16	
41	0.49	0.51	0.54	0.56	0.58	0.61	0.63	0.65	0.67	80
45	0.43	0.45	0.48	0.50	0.52	0.55	0.57	0.59	0.62	
48	0.37	0.39	0.42	0.44	0.46	0.49	0.51	0.54	0.56	

PIPE Ø 5" SDR 11

T _e T _i	79	81	82	84	86	88	90	91	93	humidity%
41	0.11	0.13	0.14	0.15	0.16	0.17	0.19	0.20	0.21	60
45	0.08	0.09	0.11	0.12	0.13	0.14	0.15	0.17	0.18	
48	0.05	0.06	0.07	0.09	0.10	0.11	0.12	0.13	0.15	
41	0.49	0.51	0.54	0.56	0.58	0.61	0.63	0.65	0.67	80
45	0.43	0.45	0.48	0.50	0.52	0.55	0.57	0.59	0.62	
48	0.37	0.39	0.42	0.44	0.46	0.49	0.51	0.54	0.56	

PIPE Ø 6" SDR 11

T _e T _i	79	81	82	84	86	88	90	91	93	humidity%
41	0.09	0.10	0.11	0.13	0.14	0.15	0.16	0.17	0.19	60
45	0.06	0.07	0.08	0.09	0.11	0.12	0.13	0.14	0.16	
48	0.03	0.04	0.05	0.06	0.07	0.09	0.10	0.11	0.13	
41	0.47	0.50	0.52	0.54	0.57	0.59	0.61	0.64	0.66	80
45	0.41	0.44	0.46	0.48	0.51	0.53	0.56	0.58	0.60	
48	0.35	0.38	0.40	0.43	0.45	0.47	0.50	0.52	0.55	

PIPE Ø 8" SDR 11

T _e T _i	79	81	82	84	86	88	90	91	93	humidity%
41	0.07	0.08	0.09	0.10	0.11	0.13	0.14	0.15	0.16	60
45	0.04	0.05	0.06	0.07	0.08	0.09	0.11	0.12	0.13	
48	0.00	0.02	0.03	0.04	0.06	0.07	0.08	0.09	0.10	
41	0.45	0.48	0.51	0.53	0.56	0.58	0.60	0.63	0.65	80
45	0.39	0.42	0.44	0.47	0.49	0.52	0.54	0.57	0.59	
48	0.32	0.35	0.38	0.41	0.43	0.46	0.48	0.51	0.54	

PIPE Ø 10" SDR 11

T _e T _i	79	81	82	84	86	88	90	91	93	humidity%
41	0.04	0.05	0.06	0.07	0.08	0.09	0.11	0.12	0.13	60
45	0.00	0.02	0.03	0.04	0.06	0.07	0.08	0.09	0.10	
48	0.00	0.00	0.00	0.01	0.02	0.04	0.05	0.06	0.07	
41	0.43	0.46	0.48	0.51	0.54	0.57	0.59	0.62	0.65	80
45	0.36	0.39	0.43	0.46	0.49	0.52	0.55	0.58	0.57	
48	0.30	0.33	0.35	0.38	0.41	0.44	0.46	0.49	0.52	

PIPE Ø 12" SDR 11

Ti	Te	79	81	82	84	86	88	90	91	93	humidity%
41	0.00	0.01	0.02	0.03	0.04	0.06	0.07	0.08	0.09		
45	0.00	0.00	0.00	0.00	0.02	0.03	0.04	0.05	0.06		60
48	0.00	0.00	0.00	0.00	0.00	0.00	0.01	0.02	0.03		
41	0.41	0.43	0.46	0.49	0.52	0.54	0.57	0.60	0.63		
45	0.33	0.35	0.38	0.41	0.44	0.46	0.49	0.52	0.55		80
48	0.26	0.29	0.31	0.34	0.37	0.40	0.43	0.45	0.48		

PIPE Ø 14" SDR 11

Ti	Te	79	81	82	84	86	88	90	91	93	humidity%
41	0.00	0.00	0.00	0.01	0.02	0.03	0.04	0.06	0.07		
45	0.00	0.00	0.00	0.00	0.00	0.00	0.01	0.02	0.04		60
48	0.00	0.00	0.00	0.00	0.00	0.00	0.00	0.00	0.01		
41	0.37	0.40	0.43	0.45	0.48	0.51	0.54	0.56	0.59		
45	0.30	0.33	0.35	0.38	0.41	0.44	0.46	0.49	0.52		80
48	0.23	0.26	0.29	0.31	0.34	0.37	0.40	0.43	0.45		

PIPE Ø 16" SDR 11

Ti	Te	79	81	82	84	86	88	90	91	93	humidity%
41	0.00	0.00	0.00	0.00	0.00	0.00	0.01	0.02	0.04		
45	0.00	0.00	0.00	0.00	0.00	0.00	0.00	0.00	0.01		60
48	0.00	0.00	0.00	0.00	0.00	0.00	0.00	0.00	0.00		
41	0.34	0.37	0.40	0.43	0.45	0.48	0.51	0.54	0.56		
45	0.28	0.30	0.33	0.36	0.39	0.41	0.44	0.47	0.50		80
48	0.20	0.23	0.26	0.29	0.31	0.34	0.37	0.40	0.43		

SDR 17

PIPE Ø 2" SDR 17

Ti	Te	79	81	82	84	86	88	90	91	93	humidity%
41	0.17	0.18	0.19	0.20	0.21	0.22	0.24	0.25	0.26		
45	0.14	0.15	0.16	0.17	0.19	0.20	0.21	0.22	0.23		60
48	0.11	0.12	0.13	0.14	0.15	0.17	0.18	0.19	0.20		
41	0.50	0.53	0.55	0.57	0.60	0.62	0.65	0.67	0.69		
45	0.45	0.47	0.50	0.52	0.54	0.57	0.59	0.61	0.64		80
48	0.39	0.42	0.44	0.46	0.49	0.51	0.54	0.56	0.58		

PIPE Ø 2-1/2" SDR 17

Ti	Te	79	81	82	84	86	88	90	91	93	humidity%
41	0.16	0.17	0.19	0.20	0.21	0.22	0.23	0.24	0.26		
45	0.13	0.15	0.16	0.17	0.18	0.19	0.20	0.22	0.23		60
48	0.10	0.11	0.13	0.14	0.15	0.16	0.17	0.19	0.20		
41	0.51	0.54	0.56	0.58	0.61	0.63	0.65	0.68	0.70		
45	0.46	0.48	0.50	0.53	0.55	0.57	0.60	0.62	0.65		80
48	0.40	0.43	0.45	0.47	0.50	0.52	0.54	0.57	0.59		

PIPE Ø 3" SDR 17

Ti	Te	79	81	82	84	86	88	90	91	93	humidity%
41	0.16	0.17	0.18	0.19	0.20	0.22	0.23	0.24	0.25		
45	0.13	0.14	0.15	0.17	0.18	0.19	0.20	0.21	0.22		60
48	0.10	0.11	0.12	0.13	0.15	0.16	0.17	0.18	0.19		
41	0.52	0.54	0.56	0.59	0.61	0.63	0.66	0.68	0.70		
45	0.46	0.48	0.50	0.53	0.55	0.57	0.60	0.62	0.65		80
48	0.40	0.42	0.44	0.47	0.49	0.52	0.54	0.56	0.59		

PIPE Ø 4" SDR 17

Ti	Te	79	81	82	84	86	88	90	91	93	humidity%
41	0.15	0.17	0.18	0.19	0.20	0.21	0.22	0.24	0.25		
45	0.13	0.14	0.15	0.16	0.17	0.19	0.20	0.21	0.22		60
48	0.09	0.11	0.12	0.13	0.14	0.15	0.17	0.18	0.19		
41	0.52	0.54	0.56	0.59	0.61	0.63	0.66	0.68	0.70		
45	0.46	0.48	0.50	0.53	0.55	0.57	0.60	0.62	0.65		80
48	0.40	0.42	0.44	0.47	0.49	0.52	0.54	0.56	0.59		

PIPE Ø 5" SDR 17

Ti	Te	79	81	82	84	86	88	90	91	93	humidity%
41	0.15	0.16	0.17	0.18	0.19	0.20	0.22	0.23	0.24		
45	0.12	0.13	0.14	0.15	0.17	0.18	0.19	0.20	0.21		60
48	0.09	0.10	0.11	0.12	0.13	0.15	0.16	0.17	0.18		
41	0.52	0.54	0.57	0.59	0.61	0.64	0.66	0.69	0.71		
45	0.46	0.48	0.50	0.53	0.55	0.57	0.60	0.62	0.65		80
48	0.40	0.43	0.45	0.48	0.51	0.54	0.56	0.59	0.62		

PIPE Ø 6" SDR 17

Ti	Te	79	81	82	84	86	88	90	91	93	humidity%
41	0.16	0.17	0.18	0.19	0.20	0.21	0.22	0.22	0.23		
45	0.13	0.15	0.15	0.17	0.18	0.19	0.20	0.20	0.22		60
48	0.11	0.12	0.13	0.14	0.15	0.17	0.18	0.19	0.20		
41	0.46	0.48	0.50	0.52	0.53	0.55	0.57	0.58	0.60		
45	0.41	0.43	0.45	0.47	0.48	0.50	0.52	0.54	0.56		80
48	0.36	0.38	0.40	0.42	0.44	0.45	0.47	0.49	0.52		

PIPE Ø 8" SDR 17

Ti	Te	79	81	82	84	86	88	90	91	93	humidity%
41	0.16	0.17	0.18	0.19	0.20	0.21	0.22	0.23	0.24		
45	0.13	0.14	0.15	0.16	0.17	0.18	0.20	0.20	0.22		60
48	0.10	0.11	0.13	0.14	0.15	0.16	0.17	0.18	0.19		
41	0.47	0.49	0.51	0.53	0.55	0.57	0.59	0.61	0.63		
45	0.42	0.44	0.46	0.48	0.50	0.52	0.54	0.56	0.58		80
48	0.37	0.39	0.41	0.43	0.45	0.47	0.49	0.51	0.53		

PIPE Ø 10" SDR 17

Ti	Te	79	81	82	84	86	88	90	91	93	humidity%
41	0.15	0.17	0.18	0.19	0.20	0.21	0.22	0.23	0.24		
45	0.13	0.14	0.15	0.16	0.17	0.18	0.19	0.20	0.21		60
48	0.10	0.11	0.12	0.13	0.15	0.16	0.17	0.18	0.19		
41	0.48	0.50	0.52	0.54	0.56	0.58	0.60	0.62	0.64		
45	0.43	0.45	0.47	0.49	0.51	0.53	0.55	0.57	0.59		80
48	0.37	0.40	0.42	0.44	0.46	0.48	0.50	0.52	0.54		

PIPE Ø 12" SDR 17

Ti	Te	79	81	82	84	86	88	90	91	93	humidity%
41	0.15	0.16	0.17	0.19	0.20	0.20	0.22	0.22	0.24		
45	0.12	0.13	0.14	0.15	0.17	0.17	0.19	0.20	0.21		60
48	0.09	0.11	0.11	0.13	0.14	0.15	0.16	0.17	0.19		
41	0.48	0.50	0.52	0.54	0.56	0.58	0.60	0.62	0.64		
45	0.43	0.45	0.48	0.50	0.52	0.54	0.56	0.58	0.60		80
48	0.38	0.40	0.42	0.44	0.46	0.48	0.50	0.52	0.55		

PIPE Ø 14" SDR 17

$\frac{T_e}{T_i}$	79	81	82	84	86	88	90	91	93	humidity%
41	0.14	0.15	0.17	0.18	0.19	0.20	0.21	0.22	0.23	60
45	0.11	0.13	0.14	0.15	0.16	0.18	0.19	0.20	0.20	
48	0.08	0.10	0.11	0.12	0.13	0.14	0.15	0.17	0.18	
41	0.49	0.51	0.54	0.56	0.58	0.60	0.62	0.64	0.66	80
45	0.44	0.46	0.48	0.51	0.53	0.55	0.57	0.59	0.61	
48	0.38	0.41	0.43	0.45	0.48	0.50	0.52	0.54	0.56	

PIPE Ø 16" SDR 17

$\frac{T_e}{T_i}$	79	81	82	84	86	88	90	91	93	humidity%
41	0.13	0.15	0.16	0.17	0.18	0.19	0.20	0.21	0.22	60
45	0.11	0.12	0.13	0.14	0.15	0.17	0.18	0.19	0.20	
48	0.07	0.09	0.10	0.11	0.12	0.13	0.15	0.16	0.17	
41	0.49	0.51	0.54	0.56	0.58	0.60	0.62	0.64	0.66	80
45	0.43	0.45	0.48	0.50	0.52	0.54	0.56	0.59	0.61	
48	0.37	0.40	0.43	0.45	0.47	0.49	0.51	0.53	0.56	

PIPE Ø 18" SDR 17

$\frac{T_e}{T_i}$	79	81	82	84	86	88	90	91	93	humidity%
41	0.12	0.13	0.15	0.16	0.17	0.18	0.19	0.20	0.22	60
45	0.09	0.11	0.12	0.13	0.14	0.15	0.17	0.18	0.19	
48	0.06	0.07	0.09	0.10	0.11	0.12	0.13	0.15	0.16	
41	0.49	0.51	0.54	0.56	0.58	0.61	0.63	0.65	0.67	80
45	0.43	0.45	0.48	0.50	0.52	0.55	0.57	0.59	0.62	
48	0.37	0.39	0.42	0.44	0.46	0.49	0.51	0.54	0.56	

PIPE Ø 20" SDR 17

$\frac{T_e}{T_i}$	79	81	82	84	86	88	90	91	93	humidity%
41	0.11	0.13	0.14	0.15	0.16	0.17	0.19	0.20	0.21	60
45	0.08	0.09	0.11	0.12	0.13	0.14	0.15	0.17	0.18	
48	0.05	0.06	0.07	0.09	0.10	0.11	0.12	0.13	0.15	
41	0.49	0.51	0.54	0.56	0.58	0.61	0.63	0.65	0.67	80
45	0.43	0.45	0.48	0.50	0.52	0.55	0.57	0.59	0.62	
48	0.37	0.39	0.42	0.44	0.46	0.49	0.51	0.54	0.56	

PIPE Ø 22" SDR 17

$\frac{T_e}{T_i}$	79	81	82	84	86	88	90	91	93	humidity%
41	0.09	0.10	0.11	0.13	0.14	0.15	0.16	0.17	0.19	60
45	0.06	0.07	0.08	0.09	0.11	0.12	0.13	0.14	0.16	
48	0.03	0.04	0.05	0.06	0.07	0.09	0.10	0.11	0.13	
41	0.47	0.50	0.52	0.54	0.57	0.59	0.61	0.64	0.66	80
45	0.41	0.44	0.46	0.48	0.51	0.53	0.56	0.58	0.60	
48	0.35	0.38	0.40	0.43	0.45	0.47	0.50	0.52	0.55	

PIPE Ø 24" SDR 17

$\frac{T_e}{T_i}$	79	81	82	84	86	88	90	91	93	humidity%
41	0.07	0.08	0.09	0.10	0.11	0.13	0.14	0.15	0.16	60
45	0.04	0.05	0.06	0.07	0.08	0.09	0.11	0.12	0.13	
48	0.00	0.02	0.03	0.04	0.06	0.07	0.08	0.09	0.10	
41	0.45	0.48	0.51	0.53	0.56	0.58	0.60	0.63	0.65	80
45	0.39	0.42	0.44	0.47	0.49	0.52	0.54	0.57	0.59	
48	0.32	0.35	0.38	0.41	0.43	0.46	0.48	0.51	0.54	



4.6 VELOCITY, HEADLOSS & PRESSURE DROP vs. FLOW RATE

VELOCITY, HEADLOSS & PRESSURE DROP vs. FLOW RATE									
1/2" SDR 7.3	NIRON CLIMA (middle layer with fiberglass)			NIRON FG RED (middle layer with fiberglass)			NIRON BLUE NIRON MONO GREY		
	1/2 Inch Pipe SDR 7.3, 0.787 inch OD, 0.57 inch ID			1/2 Inch Pipe SDR 7.3, 0.787 inch OD, 0.57 inch ID			1/2 Inch Pipe SDR 7.3, 0.787 inch OD, 0.57 inch ID		
Flow (gpm)	Velocity (ft/sec)	Headloss (ft/100ft)	ΔP (psi/100ft)	Velocity (ft/sec)	Headloss (ft/100ft)	ΔP (psi/100ft)	Velocity (ft/sec)	Headloss (ft/100ft)	ΔP (psi/100ft)
0.5	0.62	0.42	0.18	0.62	0.42	0.18	0.62	0.42	0.18
1	1.25	1.50	0.65	1.25	1.50	0.65	1.25	1.50	0.65
1.5	1.87	3.17	1.37	1.87	3.17	1.37	1.87	3.17	1.37
2	2.50	5.40	2.34	2.50	5.40	2.34	2.50	5.40	2.34
2.5	3.12	8.16	3.53	3.12	8.16	3.53	3.12	8.16	3.53
3	3.75	11.44	4.95	3.75	11.44	4.95	3.75	11.44	4.95
3.5	4.37	15.21	6.59	4.37	15.21	6.59	4.37	15.21	6.59
4	5.00	19.47	8.43	5.00	19.47	8.43	5.00	19.47	8.43
4.5	5.62	24.21	10.48	5.62	24.21	10.48	5.62	24.21	10.48
5	6.25	29.42	12.74	6.25	29.42	12.74	6.25	29.42	12.74
5.5	6.87	35.10	15.20	6.87	35.10	15.20	6.87	35.10	15.20
6	7.50	41.23	17.85	7.50	41.23	17.85	7.50	41.23	17.85
6.5	8.12	47.81	20.70	8.12	47.81	20.70	8.12	47.81	20.70
7	8.75	54.83	23.74	8.75	54.83	23.74	8.75	54.83	23.74
7.5	9.37	62.30	26.97	9.37	62.30	26.97	9.37	62.30	26.97
8	10.00	70.20	30.40	10.00	70.20	30.40	10.00	70.20	30.40
8.5	10.62	78.53	34.00	10.62	78.53	34.00	10.62	78.53	34.00
9	11.25	87.29	37.80	11.25	87.29	37.80	11.25	87.29	37.80
9.5	11.87	96.47	41.77	11.87	96.47	41.77	11.87	96.47	41.77
10	12.50	106.07	45.93	12.50	106.07	45.93	12.50	106.07	45.93



VELOCITY, HEADLOSS & PRESSURE DROP VS. FLOW RATE

3/4" SDR 7.3	NIRON CLIMA <small>(middle layer with fiberglass)</small>			NIRON FG RED <small>(middle layer with fiberglass)</small>			NIRON BLUE NIRON MONO GREY		
	3/4 Inch Pipe <small>SDR 7.3, 0.98 inch OD, 0.71 inch ID</small>			3/4 Inch Pipe <small>SDR 7.3, 0.98 inch OD, 0.71 inch ID</small>			3/4 Inch Pipe <small>SDR 7.3, 0.98 inch OD, 0.71 inch ID</small>		
Flow (gpm)	Velocity (ft/sec)	Headloss (ft/100ft)	Δ P (psi/100ft)	Velocity (ft/sec)	Headloss (ft/100ft)	Δ P (psi/100ft)	Velocity (ft/sec)	Headloss (ft/100ft)	Δ P (psi/100ft)
1	0.80	0.51	0.22	0.80	0.51	0.22	0.80	0.51	0.22
1.5	1.20	1.07	0.46	1.20	1.07	0.46	1.20	1.07	0.46
2	1.60	1.82	0.79	1.60	1.82	0.79	1.60	1.82	0.79
2.5	2.00	2.75	1.19	2.00	2.75	1.19	2.00	2.75	1.19
3	2.40	3.86	1.67	2.40	3.86	1.67	2.40	3.86	1.67
3.5	2.80	5.13	2.22	2.80	5.13	2.22	2.80	5.13	2.22
4	3.20	6.57	2.84	3.20	6.57	2.84	3.20	6.57	2.84
4.5	3.60	8.17	3.54	3.60	8.17	3.54	3.60	8.17	3.54
5	4.00	9.93	4.30	4.00	9.93	4.30	4.00	9.93	4.30
5.5	4.40	11.84	5.13	4.40	11.84	5.13	4.40	11.84	5.13
6	4.80	13.91	6.02	4.80	13.91	6.02	4.80	13.91	6.02
6.5	5.20	16.13	6.98	5.20	16.13	6.98	5.20	16.13	6.98
7	5.60	18.50	8.01	5.60	18.50	8.01	5.60	18.50	8.01
7.5	6.00	21.01	9.10	6.00	21.01	9.10	6.00	21.01	9.10
8	6.40	23.68	10.25	6.40	23.68	10.25	6.40	23.68	10.25
8.5	6.80	26.49	11.47	6.80	26.49	11.47	6.80	26.49	11.47
9	7.20	29.44	12.75	7.20	29.44	12.75	7.20	29.44	12.75
10	8.00	35.78	15.49	8.00	35.78	15.49	8.00	35.78	15.49
11	8.80	42.68	18.48	8.80	42.68	18.48	8.80	42.68	18.48
12	9.60	50.13	21.71	9.60	50.13	21.71	9.60	50.13	21.71
13	10.40	58.14	25.17	10.40	58.14	25.17	10.40	58.14	25.17
14	11.20	66.68	28.87	11.20	66.68	28.87	11.20	66.68	28.87

VELOCITY, HEADLOSS & PRESSURE DROP VS. FLOW RATE

1" SDR 7.3	NIRON CLIMA <small>(middle layer with fiberglass)</small>			NIRON FG RED <small>(middle layer with fiberglass)</small>			NIRON BLUE NIRON MONO GREY		
	1 Inch Pipe <small>SDR 7.3, 1.26 inch OD, 0.98 inch ID</small>			1 Inch Pipe <small>SDR 7.3, 1.26 inch OD, 0.98 inch ID</small>			1 Inch Pipe <small>SDR 7.3, 1.26 inch OD, 0.98 inch ID</small>		
Flow (gpm)	Velocity (ft/sec)	Headloss (ft/100ft)	Δ P (psi/100ft)	Velocity (ft/sec)	Headloss (ft/100ft)	Δ P (psi/100ft)	Velocity (ft/sec)	Headloss (ft/100ft)	Δ P (psi/100ft)
2	0.98	0.55	0.24	0.98	0.55	0.24	0.98	0.55	0.24
3	1.46	1.16	0.50	1.46	1.16	0.50	1.46	1.16	0.50
4	1.95	1.97	0.85	1.95	1.97	0.85	1.95	1.97	0.85
5	2.44	2.98	1.29	2.44	2.98	1.29	2.44	2.98	1.29
6	2.93	4.18	1.81	2.93	4.18	1.81	2.93	4.18	1.81
7	3.42	5.56	2.41	3.42	5.56	2.41	3.42	5.56	2.41
8	3.90	7.12	3.08	3.90	7.12	3.08	3.90	7.12	3.08
9	4.39	8.85	3.83	4.39	8.85	3.83	4.39	8.85	3.83
10	4.88	10.75	4.66	4.88	10.75	4.66	4.88	10.75	4.66
11	5.37	12.83	5.55	5.37	12.83	5.55	5.37	12.83	5.55
12	5.86	15.07	6.52	5.86	15.07	6.52	5.86	15.07	6.52
13	6.35	17.47	7.57	6.35	17.47	7.57	6.35	17.47	7.57
14	6.83	20.04	8.68	6.83	20.04	8.68	6.83	20.04	8.68
15	7.32	22.77	9.86	7.32	22.77	9.86	7.32	22.77	9.86
16	7.81	25.65	11.11	7.81	25.65	11.11	7.81	25.65	11.11
17	8.30	28.70	12.43	8.30	28.70	12.43	8.30	28.70	12.43
18	8.79	31.90	13.81	8.79	31.90	13.81	8.79	31.90	13.81
19	9.27	35.26	15.27	9.27	35.26	15.27	9.27	35.26	15.27
20	9.76	38.77	16.79	9.76	38.77	16.79	9.76	38.77	16.79
21	10.25	42.43	18.37	10.25	42.43	18.37	10.25	42.43	18.37
22	10.74	46.24	20.02	10.74	46.24	20.02	10.74	46.24	20.02
23	11.23	50.20	21.74	11.23	50.20	21.74	11.23	50.20	21.74



VELOCITY, HEADLOSS & PRESSURE DROP VS. FLOW RATE

1¼" SDR 7.3	NIRON CLIMA <small>(middle layer with fiberglass)</small>			NIRON FG RED <small>(middle layer with fiberglass)</small>			NIRON BLUE NIRON MONO GREY		
	1¼ Inch Pipe <small>SDR 7.3, 1.57 inch OD, 1.14 inch ID</small>			1¼ Inch Pipe <small>SDR 7.3, 1.57 inch OD, 1.14 inch ID</small>			1¼ Inch Pipe <small>SDR 7.3, 1.57 inch OD, 1.14 inch ID</small>		
Flow (gpm)	Velocity (ft/sec)	Headloss (ft/100ft)	ΔP (psi/100ft)	Velocity (ft/sec)	Headloss (ft/100ft)	ΔP (psi/100ft)	Velocity (ft/sec)	Headloss (ft/100ft)	ΔP (psi/100ft)
5	1.56	1.01	0.44	1.56	1.01	0.44	1.56	1.01	0.44
6	1.87	1.41	0.61	1.87	1.41	0.61	1.87	1.41	0.61
7	2.19	1.88	0.81	2.19	1.88	0.81	2.19	1.88	0.81
8	2.50	2.40	1.04	2.50	2.40	1.04	2.50	2.40	1.04
9	2.81	2.98	1.29	2.81	2.98	1.29	2.81	2.98	1.29
10	3.12	3.63	1.57	3.12	3.63	1.57	3.12	3.63	1.57
11	3.44	4.33	1.87	3.44	4.33	1.87	3.44	4.33	1.87
12	3.75	5.08	2.20	3.75	5.08	2.20	3.75	5.08	2.20
13	4.06	5.89	2.55	4.06	5.89	2.55	4.06	5.89	2.55
14	4.37	6.76	2.93	4.37	6.76	2.93	4.37	6.76	2.93
15	4.69	7.68	3.33	4.69	7.68	3.33	4.69	7.68	3.33
20	6.25	13.08	5.66	6.25	13.08	5.66	6.25	13.08	5.66
21	6.56	14.31	6.20	6.56	14.31	6.20	6.56	14.31	6.20
22	6.87	15.60	6.75	6.87	15.60	6.75	6.87	15.60	6.75
23	7.18	16.93	7.33	7.18	16.93	7.33	7.18	16.93	7.33
24	7.50	18.32	7.93	7.50	18.32	7.93	7.50	18.32	7.93
25	7.81	19.76	8.56	7.81	19.76	8.56	7.81	19.76	8.56
26	8.12	21.25	9.20	8.12	21.25	9.20	8.12	21.25	9.20
27	8.43	22.78	9.87	8.43	22.78	9.87	8.43	22.78	9.87
28	8.75	24.37	10.55	8.75	24.37	10.55	8.75	24.37	10.55
29	9.06	26.00	11.26	9.06	26.00	11.26	9.06	26.00	11.26
30	9.37	27.69	11.99	9.37	27.69	11.99	9.37	27.69	11.99

VELOCITY, HEADLOSS & PRESSURE DROP VS. FLOW RATE

1½" SDR 7.3	NIRON CLIMA <small>(middle layer with fiberglass)</small>			NIRON FG RED <small>(middle layer with fiberglass)</small>			NIRON BLUE NIRON MONO GREY		
	1½ Inch Pipe <small>SDR 7.3, 1.97 inch OD, 1.43 inch ID</small>			1½ Inch Pipe <small>SDR 7.3, 1.97 inch OD, 1.43 inch ID</small>			1½ Inch Pipe <small>SDR 7.3, 1.97 inch OD, 1.43 inch ID</small>		
Flow (gpm)	Velocity (ft/sec)	Headloss (ft/100ft)	ΔP (psi/100ft)	Velocity (ft/sec)	Headloss (ft/100ft)	ΔP (psi/100ft)	Velocity (ft/sec)	Headloss (ft/100ft)	ΔP (psi/100ft)
5	1.00	0.34	0.15	1.00	0.34	0.15	1.00	0.34	0.15
6	1.20	0.48	0.21	1.20	0.48	0.21	1.20	0.48	0.21
7	1.40	0.63	0.27	1.40	0.63	0.27	1.40	0.63	0.27
8	1.60	0.81	0.35	1.60	0.81	0.35	1.60	0.81	0.35
9	1.80	1.01	0.44	1.80	1.01	0.44	1.80	1.01	0.44
10	2.00	1.22	0.53	2.00	1.22	0.53	2.00	1.22	0.53
11	2.20	1.46	0.63	2.20	1.46	0.63	2.20	1.46	0.63
12	2.40	1.71	0.74	2.40	1.71	0.74	2.40	1.71	0.74
13	2.60	1.99	0.86	2.60	1.99	0.86	2.60	1.99	0.86
14	2.80	2.28	0.99	2.80	2.28	0.99	2.80	2.28	0.99
15	3.00	2.59	1.12	3.00	2.59	1.12	3.00	2.59	1.12
20	4.00	4.41	1.91	4.00	4.41	1.91	4.00	4.41	1.91
21	4.20	4.83	2.09	4.20	4.83	2.09	4.20	4.83	2.09
22	4.40	5.26	2.28	4.40	5.26	2.28	4.40	5.26	2.28
23	4.60	5.71	2.47	4.60	5.71	2.47	4.60	5.71	2.47
24	4.80	6.18	2.68	4.80	6.18	2.68	4.80	6.18	2.68
25	5.00	6.67	2.89	5.00	6.67	2.89	5.00	6.67	2.89
30	6.00	9.34	4.04	6.00	9.34	4.04	6.00	9.34	4.04
35	7.00	12.42	5.38	7.00	12.42	5.38	7.00	12.42	5.38
40	8.00	15.90	6.89	8.00	15.90	6.89	8.00	15.90	6.89
45	9.00	19.77	8.56	9.00	19.77	8.56	9.00	19.77	8.56
50	10.00	24.03	10.40	10.00	24.03	10.40	10.00	24.03	10.40

VELOCITY, HEADLOSS & PRESSURE DROP VS. FLOW RATE

2" SDR 7.3	NIRON CLIMA <small>(middle layer with fiberglass)</small>			NIRON FG RED <small>(middle layer with fiberglass)</small>			NIRON BLUE NIRON MONO GREY		
	2 Inch Pipe <small>SDR 7.3, 2.48 inch OD, 1.80 inch ID</small>			2 Inch Pipe <small>SDR 7.3, 2.48 inch OD, 1.80 inch ID</small>			2 Inch Pipe <small>SDR 7.3, 2.48 inch OD, 1.80 inch ID</small>		
Flow (gpm)	Velocity (ft/sec)	Headloss (ft/100ft)	Δ P (psi/100ft)	Velocity (ft/sec)	Headloss (ft/100ft)	Δ P (psi/100ft)	Velocity (ft/sec)	Headloss (ft/100ft)	Δ P (psi/100ft)
10	1.26	0.40	0.17	1.26	0.40	0.17	1.26	0.40	0.17
11	1.39	0.47	0.21	1.39	0.47	0.21	1.39	0.47	0.21
12	1.51	0.56	0.24	1.51	0.56	0.24	1.51	0.56	0.24
13	1.64	0.65	0.28	1.64	0.65	0.28	1.64	0.65	0.28
14	1.76	0.74	0.32	1.76	0.74	0.32	1.76	0.74	0.32
15	1.89	0.84	0.36	1.89	0.84	0.36	1.89	0.84	0.36
20	2.52	1.43	0.62	2.52	1.43	0.62	2.52	1.43	0.62
25	3.15	2.16	0.94	3.15	2.16	0.94	3.15	2.16	0.94
30	3.78	3.03	1.31	3.78	3.03	1.31	3.78	3.03	1.31
35	4.41	4.03	1.75	4.41	4.03	1.75	4.41	4.03	1.75
40	5.04	5.16	2.23	5.04	5.16	2.23	5.04	5.16	2.23
45	5.67	6.42	2.78	5.67	6.42	2.78	5.67	6.42	2.78
50	6.30	7.80	3.38	6.30	7.80	3.38	6.30	7.80	3.38
55	6.93	9.30	4.03	6.93	9.30	4.03	6.93	9.30	4.03
60	7.56	10.92	4.73	7.56	10.92	4.73	7.56	10.92	4.73
65	8.19	12.67	5.49	8.19	12.67	5.49	8.19	12.67	5.49
70	8.82	14.53	6.29	8.82	14.53	6.29	8.82	14.53	6.29
75	9.44	16.51	7.15	9.44	16.51	7.15	9.44	16.51	7.15
80	10.07	18.60	8.05	10.07	18.60	8.05	10.07	18.60	8.05
85	10.70	20.81	9.01	10.70	20.81	9.01	10.70	20.81	9.01
90	11.33	23.13	10.02	11.33	23.13	10.02	11.33	23.13	10.02
100	12.59	28.11	12.17	12.59	28.11	12.17	12.59	28.11	12.17



VELOCITY, HEADLOSS & PRESSURE DROP VS. FLOW RATE

2½" SDR 7.3	NIRON CLIMA <small>(middle layer with fiberglass)</small>			NIRON FG RED <small>(middle layer with fiberglass)</small>			NIRON BLUE NIRON MONO GREY		
	2½ Inch Pipe <small>SDR 7.3, 2.95 inch OD, 2.14 inch ID</small>			2½ Inch Pipe <small>SDR 7.3, 2.95 inch OD, 2.14 inch ID</small>			2½ Inch Pipe <small>SDR 7.3, 2.95 inch OD, 2.14 inch ID</small>		
Flow (gpm)	Velocity (ft/sec)	Headloss (ft/100ft)	ΔP (psi/100ft)	Velocity (ft/sec)	Headloss (ft/100ft)	ΔP (psi/100ft)	Velocity (ft/sec)	Headloss (ft/100ft)	ΔP (psi/100ft)
10	0.89	0.17	0.07	0.89	0.17	0.07	0.89	0.17	0.07
11	0.98	0.20	0.09	0.98	0.20	0.09	0.98	0.20	0.09
12	1.07	0.24	0.10	1.07	0.24	0.10	1.07	0.24	0.10
13	1.16	0.28	0.12	1.16	0.28	0.12	1.16	0.28	0.12
14	1.24	0.32	0.14	1.24	0.32	0.14	1.24	0.32	0.14
15	1.33	0.36	0.16	1.33	0.36	0.16	1.33	0.36	0.16
20	1.78	0.61	0.27	1.78	0.61	0.27	1.78	0.61	0.27
25	2.22	0.93	0.40	2.22	0.93	0.40	2.22	0.93	0.40
30	2.67	1.30	0.56	2.67	1.30	0.56	2.67	1.30	0.56
35	3.11	1.72	0.75	3.11	1.72	0.75	3.11	1.72	0.75
40	3.55	2.21	0.96	3.55	2.21	0.96	3.55	2.21	0.96
45	4.00	2.74	1.19	4.00	2.74	1.19	4.00	2.74	1.19
50	4.44	3.34	1.44	4.44	3.34	1.44	4.44	3.34	1.44
55	4.89	3.98	1.72	4.89	3.98	1.72	4.89	3.98	1.72
60	5.33	4.67	2.02	5.33	4.67	2.02	5.33	4.67	2.02
65	5.78	5.42	2.35	5.78	5.42	2.35	5.78	5.42	2.35
70	6.22	6.22	2.69	6.22	6.22	2.69	6.22	6.22	2.69
75	6.66	7.06	3.06	6.66	7.06	3.06	6.66	7.06	3.06
80	7.11	7.96	3.45	7.11	7.96	3.45	7.11	7.96	3.45
90	8.00	9.90	4.28	8.00	9.90	4.28	8.00	9.90	4.28
100	8.89	12.02	5.21	8.89	12.02	5.21	8.89	12.02	5.21
120	10.66	16.85	7.30	10.66	16.85	7.30	10.66	16.85	7.30



VELOCITY, HEADLOSS & PRESSURE DROP VS. FLOW RATE

3" SDR 7.3	NIRON CLIMA <small>(middle layer with fiberglass)</small>			NIRON FG RED <small>(middle layer with fiberglass)</small>			NIRON BLUE NIRON MONO GREY		
	3 Inch Pipe <small>SDR 7.3, 3.54 inch OD, 2.57 inch ID</small>			3 Inch Pipe <small>SDR 7.3, 3.54 inch OD, 2.57 inch ID</small>			3 Inch Pipe <small>SDR 7.3, 3.54 inch OD, 2.57 inch ID</small>		
Flow (gpm)	Velocity (ft/sec)	Headloss (ft/100ft)	Δ P (psi/100ft)	Velocity (ft/sec)	Headloss (ft/100ft)	Δ P (psi/100ft)	Velocity (ft/sec)	Headloss (ft/100ft)	Δ P (psi/100ft)
20	1.23	0.25	0.11	1.23	0.25	0.11	1.23	0.25	0.11
21	1.30	0.28	0.12	1.30	0.28	0.12	1.30	0.28	0.12
22	1.36	0.30	0.13	1.36	0.30	0.13	1.36	0.30	0.13
23	1.42	0.33	0.14	1.42	0.33	0.14	1.42	0.33	0.14
24	1.48	0.35	0.15	1.48	0.35	0.15	1.48	0.35	0.15
25	1.54	0.38	0.16	1.54	0.38	0.16	1.54	0.38	0.16
30	1.85	0.53	0.23	1.85	0.53	0.23	1.85	0.53	0.23
35	2.16	0.71	0.31	2.16	0.71	0.31	2.16	0.71	0.31
40	2.47	0.91	0.39	2.47	0.91	0.39	2.47	0.91	0.39
45	2.78	1.13	0.49	2.78	1.13	0.49	2.78	1.13	0.49
50	3.09	1.37	0.59	3.09	1.37	0.59	3.09	1.37	0.59
60	3.70	1.92	0.83	3.70	1.92	0.83	3.70	1.92	0.83
70	4.32	2.56	1.11	4.32	2.56	1.11	4.32	2.56	1.11
80	4.94	3.27	1.42	4.94	3.27	1.42	4.94	3.27	1.42
90	5.55	4.07	1.76	5.55	4.07	1.76	5.55	4.07	1.76
100	6.17	4.95	2.14	6.17	4.95	2.14	6.17	4.95	2.14
110	6.79	5.90	2.56	6.79	5.90	2.56	6.79	5.90	2.56
120	7.40	6.93	3.00	7.40	6.93	3.00	7.40	6.93	3.00
140	8.64	9.22	3.99	8.64	9.22	3.99	8.64	9.22	3.99
160	9.87	11.81	5.11	9.87	11.81	5.11	9.87	11.81	5.11
180	11.11	14.68	6.36	11.11	14.68	6.36	11.11	14.68	6.36
200	12.34	17.84	7.72	12.34	17.84	7.72	12.34	17.84	7.72



VELOCITY, HEADLOSS & PRESSURE DROP VS. FLOW RATE

4" SDR 7.3	NIRON CLIMA <small>(middle layer with fiberglass)</small>			NIRON FG RED <small>(middle layer with fiberglass)</small>			NIRON BLUE NIRON MONO GREY		
	4 Inch Pipe <small>SDR 7.3, 4.33 inch OD, 3.14 inch ID</small>			4 Inch Pipe <small>SDR 7.3, 4.33 inch OD, 3.14 inch ID</small>			4 Inch Pipe <small>SDR 7.3, 4.33 inch OD, 3.14 inch ID</small>		
Flow (gpm)	Velocity (ft/sec)	Headloss (ft/100ft)	Δ P (psi/100ft)	Velocity (ft/sec)	Headloss (ft/100ft)	Δ P (psi/100ft)	Velocity (ft/sec)	Headloss (ft/100ft)	Δ P (psi/100ft)
20	0.83	0.09	0.04	0.83	0.09	0.04	0.83	0.09	0.04
25	1.03	0.14	0.06	1.03	0.14	0.06	1.03	0.14	0.06
30	1.24	0.20	0.09	1.24	0.20	0.09	1.24	0.20	0.09
40	1.65	0.34	0.15	1.65	0.34	0.15	1.65	0.34	0.15
50	2.07	0.52	0.22	2.07	0.52	0.22	2.07	0.52	0.22
60	2.48	0.72	0.31	2.48	0.72	0.31	2.48	0.72	0.31
70	2.89	0.96	0.42	2.89	0.96	0.42	2.89	0.96	0.42
80	3.30	1.23	0.53	3.30	1.23	0.53	3.30	1.23	0.53
90	3.72	1.53	0.66	3.72	1.53	0.66	3.72	1.53	0.66
100	4.13	1.86	0.81	4.13	1.86	0.81	4.13	1.86	0.81
110	4.54	2.22	0.96	4.54	2.22	0.96	4.54	2.22	0.96
120	4.96	2.61	1.13	4.96	2.61	1.13	4.96	2.61	1.13
130	5.37	3.03	1.31	5.37	3.03	1.31	5.37	3.03	1.31
140	5.78	3.47	1.50	5.78	3.47	1.50	5.78	3.47	1.50
150	6.20	3.94	1.71	6.20	3.94	1.71	6.20	3.94	1.71
160	6.61	4.44	1.92	6.61	4.44	1.92	6.61	4.44	1.92
170	7.02	4.97	2.15	7.02	4.97	2.15	7.02	4.97	2.15
180	7.44	5.52	2.39	7.44	5.52	2.39	7.44	5.52	2.39
190	7.85	6.11	2.64	7.85	6.11	2.64	7.85	6.11	2.64
200	8.26	6.71	2.91	8.26	6.71	2.91	8.26	6.71	2.91
225	9.29	8.35	3.61	9.29	8.35	3.61	9.29	8.35	3.61
250	10.33	10.14	4.39	10.33	10.14	4.39	10.33	10.14	4.39

VELOCITY, HEADLOSS & PRESSURE DROP VS. FLOW RATE									
5" SDR 7.3	NIRON CLIMA (middle layer with fiberglass)			NIRON FG RED (middle layer with fiberglass)			NIRON BLUE NIRON MONO GREY		
	5 Inch Pipe SDR 7.3, 4.92 inch OD, 3.57 inch ID			5 Inch Pipe SDR 7.3, 4.92 inch OD, 3.57 inch ID			5 Inch Pipe SDR 7.3, 4.92 inch OD, 3.57 inch ID		
Flow (gpm)	Velocity (ft/sec)	Headloss (ft/100ft)	Δ P (psi/100ft)	Velocity (ft/sec)	Headloss (ft/100ft)	Δ P (psi/100ft)	Velocity (ft/sec)	Headloss (ft/100ft)	Δ P (psi/100ft)
40	1.28	0.18	0.08	1.28	0.18	0.08	1.28	0.18	0.08
50	1.60	0.28	0.12	1.60	0.28	0.12	1.60	0.28	0.12
60	1.92	0.39	0.17	1.92	0.39	0.17	1.92	0.39	0.17
70	2.24	0.52	0.22	2.24	0.52	0.22	2.24	0.52	0.22
80	2.56	0.66	0.29	2.56	0.66	0.29	2.56	0.66	0.29
90	2.88	0.82	0.36	2.88	0.82	0.36	2.88	0.82	0.36
100	3.20	1.00	0.43	3.20	1.00	0.43	3.20	1.00	0.43
110	3.52	1.19	0.52	3.52	1.19	0.52	3.52	1.19	0.52
120	3.84	1.40	0.61	3.84	1.40	0.61	3.84	1.40	0.61
130	4.16	1.62	0.70	4.16	1.62	0.70	4.16	1.62	0.70
140	4.48	1.86	0.81	4.48	1.86	0.81	4.48	1.86	0.81
150	4.80	2.12	0.92	4.80	2.12	0.92	4.80	2.12	0.92
160	5.12	2.38	1.03	5.12	2.38	1.03	5.12	2.38	1.03
170	5.44	2.67	1.15	5.44	2.67	1.15	5.44	2.67	1.15
180	5.76	2.96	1.28	5.76	2.96	1.28	5.76	2.96	1.28
190	6.08	3.28	1.42	6.08	3.28	1.42	6.08	3.28	1.42
200	6.40	3.60	1.56	6.40	3.60	1.56	6.40	3.60	1.56
220	7.04	4.30	1.86	7.04	4.30	1.86	7.04	4.30	1.86
240	7.68	5.05	2.19	7.68	5.05	2.19	7.68	5.05	2.19
260	8.32	5.85	2.53	8.32	5.85	2.53	8.32	5.85	2.53
280	8.96	6.71	2.91	8.96	6.71	2.91	8.96	6.71	2.91
300	9.60	7.63	3.30	9.60	7.63	3.30	9.60	7.63	3.30



VELOCITY, HEADLOSS & PRESSURE DROP VS. FLOW RATE

6" SDR 7.3	NIRON CLIMA <small>(middle layer with fiberglass)</small>			NIRON FG RED <small>(middle layer with fiberglass)</small>			NIRON BLUE NIRON MONO GREY		
	6 Inch Pipe <small>SDR 7.3, 6.30 inch OD, 4.57 inch ID</small>			6 Inch Pipe <small>SDR 7.3, 6.30 inch OD, 4.57 inch ID</small>			6 Inch Pipe <small>SDR 7.3, 6.30 inch OD, 4.57 inch ID</small>		
Flow (gpm)	Velocity (ft/sec)	Headloss (ft/100ft)	Δ P (psi/100ft)	Velocity (ft/sec)	Headloss (ft/100ft)	Δ P (psi/100ft)	Velocity (ft/sec)	Headloss (ft/100ft)	Δ P (psi/100ft)
80	1.56	0.20	0.09	1.56	0.20	0.09	1.56	0.20	0.09
100	1.95	0.30	0.13	1.95	0.30	0.13	1.95	0.30	0.13
120	2.34	0.42	0.18	2.34	0.42	0.18	2.34	0.42	0.18
140	2.73	0.56	0.24	2.73	0.56	0.24	2.73	0.56	0.24
160	3.12	0.72	0.31	3.12	0.72	0.31	3.12	0.72	0.31
180	3.51	0.89	0.39	3.51	0.89	0.39	3.51	0.89	0.39
200	3.90	1.08	0.47	3.90	1.08	0.47	3.90	1.08	0.47
220	4.30	1.29	0.56	4.30	1.29	0.56	4.30	1.29	0.56
240	4.69	1.52	0.66	4.69	1.52	0.66	4.69	1.52	0.66
260	5.08	1.76	0.76	5.08	1.76	0.76	5.08	1.76	0.76
280	5.47	2.02	0.87	5.47	2.02	0.87	5.47	2.02	0.87
300	5.86	2.29	0.99	5.86	2.29	0.99	5.86	2.29	0.99
320	6.25	2.58	1.12	6.25	2.58	1.12	6.25	2.58	1.12
340	6.64	2.89	1.25	6.64	2.89	1.25	6.64	2.89	1.25
360	7.03	3.21	1.39	7.03	3.21	1.39	7.03	3.21	1.39
380	7.42	3.55	1.54	7.42	3.55	1.54	7.42	3.55	1.54
400	7.81	3.90	1.69	7.81	3.90	1.69	7.81	3.90	1.69
425	8.30	4.37	1.89	8.30	4.37	1.89	8.30	4.37	1.89
450	8.79	4.85	2.10	8.79	4.85	2.10	8.79	4.85	2.10
475	9.27	5.36	2.32	9.27	5.36	2.32	9.27	5.36	2.32
500	9.76	5.90	2.55	9.76	5.90	2.55	9.76	5.90	2.55
525	10.25	6.45	2.79	10.25	6.45	2.79	10.25	6.45	2.79

VELOCITY, HEADLOSS & PRESSURE DROP VS. FLOW RATE

1" SDR 9	NIRON CLIMA <small>(middle layer with fiberglass)</small>			NIRON FG RED <small>(middle layer with fiberglass)</small>			NIRON BLUE NIRON MONO GREY		
	1 Inch Pipe <small>SDR 9, 1.26 inch OD, 0.98 inch ID</small>			1 Inch Pipe <small>SDR 9, 1.26 inch OD, 0.98 inch ID</small>			1 Inch Pipe <small>SDR 9, 1.26 inch OD, 0.98 inch ID</small>		
Flow (gpm)	Velocity (ft/sec)	Headloss (ft/100ft)	Δ P (psi/100ft)	Velocity (ft/sec)	Headloss (ft/100ft)	Δ P (psi/100ft)	Velocity (ft/sec)	Headloss (ft/100ft)	Δ P (psi/100ft)
2	0.85	0.39	0.17	0.85	0.39	0.17	0.85	0.39	0.17
3	1.28	0.83	0.36	1.28	0.83	0.36	1.28	0.83	0.36
4	1.70	1.41	0.61	1.70	1.41	0.61	1.70	1.41	0.61
5	2.13	2.13	0.92	2.13	2.13	0.92	2.13	2.13	0.92
6	2.55	2.99	1.29	2.55	2.99	1.29	2.55	2.99	1.29
7	2.98	3.98	1.72	2.98	3.98	1.72	2.98	3.98	1.72
8	3.40	5.09	2.20	3.40	5.09	2.20	3.40	5.09	2.20
9	3.83	6.33	2.74	3.83	6.33	2.74	3.83	6.33	2.74
10	4.25	7.69	3.33	4.25	7.69	3.33	4.25	7.69	3.33
11	4.68	9.17	3.97	4.68	9.17	3.97	4.68	9.17	3.97
12	5.10	10.77	4.67	5.10	10.77	4.67	5.10	10.77	4.67
13	5.53	12.49	5.41	5.53	12.49	5.41	5.53	12.49	5.41
14	5.95	14.33	6.20	5.95	14.33	6.20	5.95	14.33	6.20
15	6.38	16.28	7.05	6.38	16.28	7.05	6.38	16.28	7.05
16	6.80	18.35	7.94	6.80	18.35	7.94	6.80	18.35	7.94
17	7.23	20.52	8.89	7.23	20.52	8.89	7.23	20.52	8.89
18	7.66	22.81	9.88	7.66	22.81	9.88	7.66	22.81	9.88
19	8.08	25.21	10.92	8.08	25.21	10.92	8.08	25.21	10.92
20	8.51	27.72	12.00	8.51	27.72	12.00	8.51	27.72	12.00
21	8.93	30.34	13.14	8.93	30.34	13.14	8.93	30.34	13.14
22	9.36	33.07	14.32	9.36	33.07	14.32	9.36	33.07	14.32
23	9.78	35.90	15.55	9.78	35.90	15.55	9.78	35.90	15.55



VELOCITY, HEADLOSS & PRESSURE DROP VS. FLOW RATE

1¼" SDR 9	NIRON CLIMA <small>(middle layer with fiberglass)</small>			NIRON FG RED <small>(middle layer with fiberglass)</small>			NIRON BLUE NIRON MONO GREY		
	1¼ Inch Pipe <small>SDR 9, 1.57 inch OD, 1.22 inch ID</small>			1¼ Inch Pipe <small>SDR 9, 1.57 inch OD, 1.22 inch ID</small>			1¼ Inch Pipe <small>SDR 9, 1.57 inch OD, 1.22 inch ID</small>		
Flow (gpm)	Velocity (ft/sec)	Headloss (ft/100ft)	ΔP (psi/100ft)	Velocity (ft/sec)	Headloss (ft/100ft)	ΔP (psi/100ft)	Velocity (ft/sec)	Headloss (ft/100ft)	ΔP (psi/100ft)
5	1.36	0.72	0.31	1.36	0.72	0.31	1.36	0.72	0.31
6	1.63	1.01	0.44	1.63	1.01	0.44	1.63	1.01	0.44
7	1.91	1.34	0.58	1.91	1.34	0.58	1.91	1.34	0.58
8	2.18	1.72	0.74	2.18	1.72	0.74	2.18	1.72	0.74
9	2.45	2.13	0.92	2.45	2.13	0.92	2.45	2.13	0.92
10	2.72	2.59	1.12	2.72	2.59	1.12	2.72	2.59	1.12
11	2.99	3.09	1.34	2.99	3.09	1.34	2.99	3.09	1.34
12	3.27	3.63	1.57	3.27	3.63	1.57	3.27	3.63	1.57
13	3.54	4.21	1.82	3.54	4.21	1.82	3.54	4.21	1.82
14	3.81	4.83	2.09	3.81	4.83	2.09	3.81	4.83	2.09
15	4.08	5.49	2.38	4.08	5.49	2.38	4.08	5.49	2.38
20	5.44	9.35	4.05	5.44	9.35	4.05	5.44	9.35	4.05
21	5.72	10.23	4.43	5.72	10.23	4.43	5.72	10.23	4.43
22	5.99	11.15	4.83	5.99	11.15	4.83	5.99	11.15	4.83
23	6.26	12.11	5.24	6.26	12.11	5.24	6.26	12.11	5.24
24	6.53	13.10	5.67	6.53	13.10	5.67	6.53	13.10	5.67
25	6.80	14.13	6.12	6.80	14.13	6.12	6.80	14.13	6.12
27.5	7.49	16.85	7.30	7.49	16.85	7.30	7.49	16.85	7.30
30	8.17	19.80	8.57	8.17	19.80	8.57	8.17	19.80	8.57
32.5	8.85	22.96	9.94	8.85	22.96	9.94	8.85	22.96	9.94
35	9.53	26.33	11.40	9.53	26.33	11.40	9.53	26.33	11.40
40	10.89	33.71	14.60	10.89	33.71	14.60	10.89	33.71	14.60

VELOCITY, HEADLOSS & PRESSURE DROP VS. FLOW RATE

1½" SDR 9	NIRON CLIMA <small>(middle layer with fiberglass)</small>			NIRON FG RED <small>(middle layer with fiberglass)</small>			NIRON BLUE NIRON MONO GREY		
	1½ Inch Pipe <small>SDR 9, 1.97 inch OD, 1.53 inch ID</small>			1½ Inch Pipe <small>SDR 9, 1.97 inch OD, 1.53 inch ID</small>			1½ Inch Pipe <small>SDR 9, 1.97 inch OD, 1.53 inch ID</small>		
Flow (gpm)	Velocity (ft/sec)	Headloss (ft/100ft)	ΔP (psi/100ft)	Velocity (ft/sec)	Headloss (ft/100ft)	ΔP (psi/100ft)	Velocity (ft/sec)	Headloss (ft/100ft)	ΔP (psi/100ft)
6	1.05	0.34	0.15	1.05	0.34	0.15	1.05	0.34	0.15
7	1.22	0.45	0.20	1.22	0.45	0.20	1.22	0.45	0.20
9	1.57	0.72	0.31	1.57	0.72	0.31	1.57	0.72	0.31
10	1.74	0.88	0.38	1.74	0.88	0.38	1.74	0.88	0.38
11	1.92	1.04	0.45	1.92	1.04	0.45	1.92	1.04	0.45
12	2.09	1.23	0.53	2.09	1.23	0.53	2.09	1.23	0.53
13	2.26	1.42	0.62	2.26	1.42	0.62	2.26	1.42	0.62
14	2.44	1.63	0.71	2.44	1.63	0.71	2.44	1.63	0.71
15	2.61	1.85	0.80	2.61	1.85	0.80	2.61	1.85	0.80
16	2.79	2.09	0.90	2.79	2.09	0.90	2.79	2.09	0.90
17	2.96	2.34	1.01	2.96	2.34	1.01	2.96	2.34	1.01
18	3.14	2.60	1.12	3.14	2.60	1.12	3.14	2.60	1.12
19	3.31	2.87	1.24	3.31	2.87	1.24	3.31	2.87	1.24
20	3.48	3.15	1.37	3.48	3.15	1.37	3.48	3.15	1.37
25	4.36	4.77	2.06	4.36	4.77	2.06	4.36	4.77	2.06
30	5.23	6.68	2.89	5.23	6.68	2.89	5.23	6.68	2.89
35	6.10	8.88	3.85	6.10	8.88	3.85	6.10	8.88	3.85
40	6.97	11.37	4.92	6.97	11.37	4.92	6.97	11.37	4.92
45	7.84	14.14	6.12	7.84	14.14	6.12	7.84	14.14	6.12
50	8.71	17.18	7.44	8.71	17.18	7.44	8.71	17.18	7.44
55	9.58	20.50	8.88	9.58	20.50	8.88	9.58	20.50	8.88
60	10.45	24.08	10.43	10.45	24.08	10.43	10.45	24.08	10.43



VELOCITY, HEADLOSS & PRESSURE DROP VS. FLOW RATE

2" SDR 9	NIRON CLIMA <small>(middle layer with fiberglass)</small>			NIRON FG RED <small>(middle layer with fiberglass)</small>			NIRON BLUE NIRON MONO GREY		
	2 Inch Pipe <small>SDR 9, 2.48 inch OD, 1.93 inch ID</small>			2 Inch Pipe <small>SDR 9, 2.48 inch OD, 1.93 inch ID</small>			2 Inch Pipe <small>SDR 9, 2.48 inch OD, 1.93 inch ID</small>		
Flow (gpm)	Velocity (ft/sec)	Headloss (ft/100ft)	Δ P (psi/100ft)	Velocity (ft/sec)	Headloss (ft/100ft)	Δ P (psi/100ft)	Velocity (ft/sec)	Headloss (ft/100ft)	Δ P (psi/100ft)
10	1.10	0.28	0.12	1.10	0.28	0.12	1.10	0.28	0.12
11	1.21	0.34	0.15	1.21	0.34	0.15	1.21	0.34	0.15
12	1.32	0.40	0.17	1.32	0.40	0.17	1.32	0.40	0.17
13	1.43	0.46	0.20	1.43	0.46	0.20	1.43	0.46	0.20
14	1.54	0.53	0.23	1.54	0.53	0.23	1.54	0.53	0.23
15	1.65	0.60	0.26	1.65	0.60	0.26	1.65	0.60	0.26
20	2.19	1.02	0.44	2.19	1.02	0.44	2.19	1.02	0.44
25	2.74	1.55	0.67	2.74	1.55	0.67	2.74	1.55	0.67
30	3.29	2.17	0.94	3.29	2.17	0.94	3.29	2.17	0.94
35	3.84	2.88	1.25	3.84	2.88	1.25	3.84	2.88	1.25
40	4.39	3.69	1.60	4.39	3.69	1.60	4.39	3.69	1.60
45	4.94	4.59	1.99	4.94	4.59	1.99	4.94	4.59	1.99
50	5.49	5.58	2.41	5.49	5.58	2.41	5.49	5.58	2.41
55	6.04	6.65	2.88	6.04	6.65	2.88	6.04	6.65	2.88
60	6.58	7.81	3.38	6.58	7.81	3.38	6.58	7.81	3.38
65	7.13	9.06	3.92	7.13	9.06	3.92	7.13	9.06	3.92
70	7.68	10.39	4.50	7.68	10.39	4.50	7.68	10.39	4.50
75	8.23	11.81	5.11	8.23	11.81	5.11	8.23	11.81	5.11
80	8.78	13.30	5.76	8.78	13.30	5.76	8.78	13.30	5.76
85	9.33	14.88	6.44	9.33	14.88	6.44	9.33	14.88	6.44
90	9.88	16.54	7.16	9.88	16.54	7.16	9.88	16.54	7.16
100	10.97	20.10	8.70	10.97	20.10	8.70	10.97	20.10	8.70



VELOCITY, HEADLOSS & PRESSURE DROP VS. FLOW RATE

2½" SDR 9	NIRON CLIMA <small>(middle layer with fiberglass)</small>			NIRON FG RED <small>(middle layer with fiberglass)</small>			NIRON BLUE NIRON MONO GREY		
	2½ Inch Pipe <small>SDR 9, 2.95 inch OD, 2.30 inch ID</small>			2½ Inch Pipe <small>SDR 9, 2.95 inch OD, 2.30 inch ID</small>			2½ Inch Pipe <small>SDR 9, 2.95 inch OD, 2.30 inch ID</small>		
Flow (gpm)	Velocity (ft/sec)	Headloss (ft/100ft)	ΔP (psi/100ft)	Velocity (ft/sec)	Headloss (ft/100ft)	ΔP (psi/100ft)	Velocity (ft/sec)	Headloss (ft/100ft)	ΔP (psi/100ft)
10	0.77	0.12	0.05	0.77	0.12	0.05	0.77	0.12	0.05
11	0.85	0.14	0.06	0.85	0.14	0.06	0.85	0.14	0.06
12	0.93	0.17	0.07	0.93	0.17	0.07	0.93	0.17	0.07
13	1.01	0.20	0.09	1.01	0.20	0.09	1.01	0.20	0.09
14	1.08	0.23	0.10	1.08	0.23	0.10	1.08	0.23	0.10
15	1.16	0.26	0.11	1.16	0.26	0.11	1.16	0.26	0.11
20	1.55	0.44	0.19	1.55	0.44	0.19	1.55	0.44	0.19
25	1.94	0.66	0.29	1.94	0.66	0.29	1.94	0.66	0.29
30	2.32	0.93	0.40	2.32	0.93	0.40	2.32	0.93	0.40
35	2.71	1.23	0.53	2.71	1.23	0.53	2.71	1.23	0.53
40	3.10	1.58	0.68	3.10	1.58	0.68	3.10	1.58	0.68
50	3.87	2.39	1.03	3.87	2.39	1.03	3.87	2.39	1.03
60	4.65	3.34	1.45	4.65	3.34	1.45	4.65	3.34	1.45
70	5.42	4.45	1.92	5.42	4.45	1.92	5.42	4.45	1.92
80	6.19	5.69	2.46	6.19	5.69	2.46	6.19	5.69	2.46
90	6.97	7.08	3.06	6.97	7.08	3.06	6.97	7.08	3.06
100	7.74	8.60	3.72	7.74	8.60	3.72	7.74	8.60	3.72
110	8.52	10.26	4.44	8.52	10.26	4.44	8.52	10.26	4.44
120	9.29	12.05	5.22	9.29	12.05	5.22	9.29	12.05	5.22
130	10.07	13.97	6.05	10.07	13.97	6.05	10.07	13.97	6.05
140	10.84	16.02	6.94	10.84	16.02	6.94	10.84	16.02	6.94
150	11.61	18.21	7.88	11.61	18.21	7.88	11.61	18.21	7.88



VELOCITY, HEADLOSS & PRESSURE DROP VS. FLOW RATE

3" SDR 9	NIRON CLIMA <small>(middle layer with fiberglass)</small>			NIRON FG RED <small>(middle layer with fiberglass)</small>			NIRON BLUE NIRON MONO GREY		
	3 Inch Pipe <small>SDR 9, 3.54 inch OD, 2.76 inch ID</small>			3 Inch Pipe <small>SDR 9, 3.54 inch OD, 2.76 inch ID</small>			3 Inch Pipe <small>SDR 9, 3.54 inch OD, 2.76 inch ID</small>		
Flow (gpm)	Velocity (ft/sec)	Headloss (ft/100ft)	Δ P (psi/100ft)	Velocity (ft/sec)	Headloss (ft/100ft)	Δ P (psi/100ft)	Velocity (ft/sec)	Headloss (ft/100ft)	Δ P (psi/100ft)
20	1.08	0.18	0.08	1.08	0.18	0.08	1.08	0.18	0.08
21	1.13	0.20	0.09	1.13	0.20	0.09	1.13	0.20	0.09
22	1.18	0.21	0.09	1.18	0.21	0.09	1.18	0.21	0.09
23	1.24	0.23	0.10	1.24	0.23	0.10	1.24	0.23	0.10
24	1.29	0.25	0.11	1.29	0.25	0.11	1.29	0.25	0.11
25	1.34	0.27	0.12	1.34	0.27	0.12	1.34	0.27	0.12
30	1.61	0.38	0.17	1.61	0.38	0.17	1.61	0.38	0.17
35	1.88	0.51	0.22	1.88	0.51	0.22	1.88	0.51	0.22
40	2.15	0.65	0.28	2.15	0.65	0.28	2.15	0.65	0.28
45	2.42	0.81	0.35	2.42	0.81	0.35	2.42	0.81	0.35
50	2.69	0.98	0.43	2.69	0.98	0.43	2.69	0.98	0.43
60	3.23	1.38	0.60	3.23	1.38	0.60	3.23	1.38	0.60
70	3.76	1.83	0.79	3.76	1.83	0.79	3.76	1.83	0.79
80	4.30	2.34	1.01	4.30	2.34	1.01	4.30	2.34	1.01
90	4.84	2.91	1.26	4.84	2.91	1.26	4.84	2.91	1.26
100	5.38	3.54	1.53	5.38	3.54	1.53	5.38	3.54	1.53
110	5.91	4.22	1.83	5.91	4.22	1.83	5.91	4.22	1.83
120	6.45	4.96	2.15	6.45	4.96	2.15	6.45	4.96	2.15
140	7.53	6.59	2.86	7.53	6.59	2.86	7.53	6.59	2.86
160	8.60	8.44	3.66	8.60	8.44	3.66	8.60	8.44	3.66
180	9.68	10.50	4.55	9.68	10.50	4.55	9.68	10.50	4.55
200	10.75	12.76	5.52	10.75	12.76	5.52	10.75	12.76	5.52

VELOCITY, HEADLOSS & PRESSURE DROP VS. FLOW RATE

4" SDR 9	NIRON CLIMA <small>(middle layer with fiberglass)</small>			NIRON FG RED <small>(middle layer with fiberglass)</small>			NIRON BLUE NIRON MONO GREY		
	4 Inch Pipe <small>SDR 9, 4.33 inch OD, 3.37 inch ID</small>			4 Inch Pipe <small>SDR 9, 4.33 inch OD, 3.37 inch ID</small>			4 Inch Pipe <small>SDR 9, 4.33 inch OD, 3.37 inch ID</small>		
Flow (gpm)	Velocity (ft/sec)	Headloss (ft/100ft)	Δ P (psi/100ft)	Velocity (ft/sec)	Headloss (ft/100ft)	Δ P (psi/100ft)	Velocity (ft/sec)	Headloss (ft/100ft)	Δ P (psi/100ft)
20	0.72	0.07	0.03	0.72	0.07	0.03	0.72	0.07	0.03
25	0.90	0.10	0.04	0.90	0.10	0.04	0.90	0.10	0.04
30	1.08	0.14	0.06	1.08	0.14	0.06	1.08	0.14	0.06
40	1.44	0.24	0.11	1.44	0.24	0.11	1.44	0.24	0.11
50	1.80	0.37	0.16	1.80	0.37	0.16	1.80	0.37	0.16
60	2.16	0.52	0.22	2.16	0.52	0.22	2.16	0.52	0.22
70	2.52	0.69	0.30	2.52	0.69	0.30	2.52	0.69	0.30
80	2.88	0.88	0.38	2.88	0.88	0.38	2.88	0.88	0.38
90	3.24	1.10	0.47	3.24	1.10	0.47	3.24	1.10	0.47
100	3.60	1.33	0.58	3.60	1.33	0.58	3.60	1.33	0.58
110	3.96	1.59	0.69	3.96	1.59	0.69	3.96	1.59	0.69
120	4.32	1.87	0.81	4.32	1.87	0.81	4.32	1.87	0.81
130	4.68	2.16	0.94	4.68	2.16	0.94	4.68	2.16	0.94
140	5.04	2.48	1.07	5.04	2.48	1.07	5.04	2.48	1.07
150	5.40	2.82	1.22	5.40	2.82	1.22	5.40	2.82	1.22
160	5.76	3.18	1.38	5.76	3.18	1.38	5.76	3.18	1.38
180	6.48	3.95	1.71	6.48	3.95	1.71	6.48	3.95	1.71
200	7.20	4.80	2.08	7.20	4.80	2.08	7.20	4.80	2.08
225	8.10	5.97	2.58	8.10	5.97	2.58	8.10	5.97	2.58
250	9.00	7.25	3.14	9.00	7.25	3.14	9.00	7.25	3.14
275	9.90	8.65	3.75	9.90	8.65	3.75	9.90	8.65	3.75
300	10.80	10.16	4.40	10.80	10.16	4.40	10.80	10.16	4.40



VELOCITY, HEADLOSS & PRESSURE DROP VS. FLOW RATE

5" SDR 9	NIRON CLIMA <small>(middle layer with fiberglass)</small>			NIRON FG RED <small>(middle layer with fiberglass)</small>			NIRON BLUE NIRON MONO GREY		
	5 Inch Pipe <small>SDR 9, 4.92 inch OD, 3.83 inch ID</small>			5 Inch Pipe <small>SDR 9, 4.92 inch OD, 3.83 inch ID</small>			5 Inch Pipe <small>SDR 9, 4.92 inch OD, 3.83 inch ID</small>		
Flow (gpm)	Velocity (ft/sec)	Headloss (ft/100ft)	Δ P (psi/100ft)	Velocity (ft/sec)	Headloss (ft/100ft)	Δ P (psi/100ft)	Velocity (ft/sec)	Headloss (ft/100ft)	Δ P (psi/100ft)
40	1.11	0.13	0.06	1.11	0.13	0.06	1.11	0.13	0.06
50	1.39	0.20	0.09	1.39	0.20	0.09	1.39	0.20	0.09
60	1.67	0.28	0.12	1.67	0.28	0.12	1.67	0.28	0.12
70	1.95	0.37	0.16	1.95	0.37	0.16	1.95	0.37	0.16
80	2.23	0.47	0.20	2.23	0.47	0.20	2.23	0.47	0.20
90	2.51	0.59	0.25	2.51	0.59	0.25	2.51	0.59	0.25
100	2.79	0.71	0.31	2.79	0.71	0.31	2.79	0.71	0.31
110	3.07	0.85	0.37	3.07	0.85	0.37	3.07	0.85	0.37
120	3.34	1.00	0.43	3.34	1.00	0.43	3.34	1.00	0.43
130	3.62	1.16	0.50	3.62	1.16	0.50	3.62	1.16	0.50
140	3.90	1.33	0.58	3.90	1.33	0.58	3.90	1.33	0.58
150	4.18	1.51	0.66	4.18	1.51	0.66	4.18	1.51	0.66
175	4.88	2.01	0.87	4.88	2.01	0.87	4.88	2.01	0.87
200	5.57	2.58	1.12	5.57	2.58	1.12	5.57	2.58	1.12
225	6.27	3.20	1.39	6.27	3.20	1.39	6.27	3.20	1.39
250	6.97	3.89	1.69	6.97	3.89	1.69	6.97	3.89	1.69
275	7.67	4.64	2.01	7.67	4.64	2.01	7.67	4.64	2.01
300	8.36	5.45	2.36	8.36	5.45	2.36	8.36	5.45	2.36
325	9.06	6.32	2.74	9.06	6.32	2.74	9.06	6.32	2.74
350	9.76	7.25	3.14	9.76	7.25	3.14	9.76	7.25	3.14
375	10.45	8.24	3.57	10.45	8.24	3.57	10.45	8.24	3.57
400	11.15	9.29	4.02	11.15	9.29	4.02	11.15	9.29	4.02

VELOCITY, HEADLOSS & PRESSURE DROP VS. FLOW RATE

6" SDR 9	NIRON CLIMA <small>(middle layer with fiberglass)</small>			NIRON FG RED <small>(middle layer with fiberglass)</small>			NIRON BLUE NIRON MONO GREY		
	6 Inch Pipe <small>SDR 9, 6.30 inch OD, 4.90 inch ID</small>			6 Inch Pipe <small>SDR 9, 6.30 inch OD, 4.90 inch ID</small>			6 Inch Pipe <small>SDR 9, 6.30 inch OD, 4.90 inch ID</small>		
Flow (gpm)	Velocity (ft/sec)	Headloss (ft/100ft)	Δ P (psi/100ft)	Velocity (ft/sec)	Headloss (ft/100ft)	Δ P (psi/100ft)	Velocity (ft/sec)	Headloss (ft/100ft)	Δ P (psi/100ft)
75	1.28	0.13	0.05	1.28	0.13	0.05	1.28	0.13	0.05
100	1.70	0.21	0.09	1.70	0.21	0.09	1.70	0.21	0.09
125	2.13	0.32	0.14	2.13	0.32	0.14	2.13	0.32	0.14
150	2.55	0.45	0.20	2.55	0.45	0.20	2.55	0.45	0.20
175	2.98	0.60	0.26	2.98	0.60	0.26	2.98	0.60	0.26
200	3.40	0.77	0.34	3.40	0.77	0.34	3.40	0.77	0.34
225	3.83	0.96	0.42	3.83	0.96	0.42	3.83	0.96	0.42
250	4.25	1.17	0.51	4.25	1.17	0.51	4.25	1.17	0.51
275	4.68	1.40	0.60	4.68	1.40	0.60	4.68	1.40	0.60
300	5.10	1.64	0.71	5.10	1.64	0.71	5.10	1.64	0.71
325	5.53	1.90	0.82	5.53	1.90	0.82	5.53	1.90	0.82
350	5.95	2.18	0.94	5.95	2.18	0.94	5.95	2.18	0.94
375	6.38	2.48	1.07	6.38	2.48	1.07	6.38	2.48	1.07
400	6.80	2.79	1.21	6.80	2.79	1.21	6.80	2.79	1.21
425	7.23	3.12	1.35	7.23	3.12	1.35	7.23	3.12	1.35
450	7.66	3.47	1.50	7.66	3.47	1.50	7.66	3.47	1.50
475	8.08	3.84	1.66	8.08	3.84	1.66	8.08	3.84	1.66
500	8.51	4.22	1.83	8.51	4.22	1.83	8.51	4.22	1.83
525	8.93	4.62	2.00	8.93	4.62	2.00	8.93	4.62	2.00
550	9.36	5.03	2.18	9.36	5.03	2.18	9.36	5.03	2.18
575	9.78	5.46	2.36	9.78	5.46	2.36	9.78	5.46	2.36
600	10.21	5.91	2.56	10.21	5.91	2.56	10.21	5.91	2.56



VELOCITY, HEADLOSS & PRESSURE DROP VS. FLOW RATE

1¼" SDR 11	NIRON CLIMA <small>(middle layer with fiberglass)</small>			NIRON FG RED <small>(middle layer with fiberglass)</small>			NIRON BLUE NIRON MONO GREY		
	1¼ Inch Pipe <small>SDR 11, 1.57 inch OD, 1.29 inch ID</small>			1¼ Inch Pipe <small>SDR 11, 1.57 inch OD, 1.29 inch ID</small>			1¼ Inch Pipe <small>SDR 11, 1.57 inch OD, 1.29 inch ID</small>		
Flow (gpm)	Velocity (ft/sec)	Headloss (ft/100ft)	ΔP (psi/100ft)	Velocity (ft/sec)	Headloss (ft/100ft)	ΔP (psi/100ft)	Velocity (ft/sec)	Headloss (ft/100ft)	ΔP (psi/100ft)
5	1.23	0.56	0.24	1.23	0.56	0.24	1.23	0.56	0.24
6	1.48	0.79	0.34	1.48	0.79	0.34	1.48	0.79	0.34
7	1.72	1.05	0.45	1.72	1.05	0.45	1.72	1.05	0.45
8	1.97	1.34	0.58	1.97	1.34	0.58	1.97	1.34	0.58
9	2.21	1.67	0.72	2.21	1.67	0.72	2.21	1.67	0.72
10	2.46	2.03	0.88	2.46	2.03	0.88	2.46	2.03	0.88
11	2.71	2.42	1.05	2.71	2.42	1.05	2.71	2.42	1.05
12	2.95	2.84	1.23	2.95	2.84	1.23	2.95	2.84	1.23
13	3.20	3.29	1.43	3.20	3.29	1.43	3.20	3.29	1.43
14	3.44	3.78	1.64	3.44	3.78	1.64	3.44	3.78	1.64
15	3.69	4.29	1.86	3.69	4.29	1.86	3.69	4.29	1.86
20	4.92	7.31	3.16	4.92	7.31	3.16	4.92	7.31	3.16
21	5.17	8.00	3.46	5.17	8.00	3.46	5.17	8.00	3.46
22	5.41	8.72	3.77	5.41	8.72	3.77	5.41	8.72	3.77
23	5.66	9.46	4.10	5.66	9.46	4.10	5.66	9.46	4.10
24	5.90	10.24	4.43	5.90	10.24	4.43	5.90	10.24	4.43
25	6.15	11.04	4.78	6.15	11.04	4.78	6.15	11.04	4.78
27.5	6.76	13.17	5.70	6.76	13.17	5.70	6.76	13.17	5.70
30	7.38	15.47	6.70	7.38	15.47	6.70	7.38	15.47	6.70
32.5	7.99	17.94	7.77	7.99	17.94	7.77	7.99	17.94	7.77
35	8.61	20.58	8.91	8.61	20.58	8.91	8.61	20.58	8.91
40	9.84	26.34	11.41	9.84	26.34	11.41	9.84	26.34	11.41

VELOCITY, HEADLOSS & PRESSURE DROP VS. FLOW RATE

1½" SDR 11	NIRON CLIMA <small>(middle layer with fiberglass)</small>			NIRON FG RED <small>(middle layer with fiberglass)</small>			NIRON BLUE NIRON MONO GREY		
	1½ Inch Pipe <small>SDR 11, 1.97 inch OD, 1.61 inch ID</small>			1½ Inch Pipe <small>SDR 11, 1.97 inch OD, 1.61 inch ID</small>			1½ Inch Pipe <small>SDR 11, 1.97 inch OD, 1.61 inch ID</small>		
Flow (gpm)	Velocity (ft/sec)	Headloss (ft/100ft)	ΔP (psi/100ft)	Velocity (ft/sec)	Headloss (ft/100ft)	ΔP (psi/100ft)	Velocity (ft/sec)	Headloss (ft/100ft)	ΔP (psi/100ft)
6	0.94	0.27	0.12	0.94	0.27	0.12	0.94	0.27	0.12
7	1.10	0.35	0.15	1.10	0.35	0.15	1.10	0.35	0.15
9	1.42	0.56	0.24	1.42	0.56	0.24	1.42	0.56	0.24
10	1.57	0.68	0.30	1.57	0.68	0.30	1.57	0.68	0.30
11	1.73	0.82	0.35	1.73	0.82	0.35	1.73	0.82	0.35
12	1.89	0.96	0.41	1.89	0.96	0.41	1.89	0.96	0.41
13	2.05	1.11	0.48	2.05	1.11	0.48	2.05	1.11	0.48
14	2.20	1.27	0.55	2.20	1.27	0.55	2.20	1.27	0.55
15	2.36	1.45	0.63	2.36	1.45	0.63	2.36	1.45	0.63
16	2.52	1.63	0.71	2.52	1.63	0.71	2.52	1.63	0.71
17	2.68	1.82	0.79	2.68	1.82	0.79	2.68	1.82	0.79
18	2.83	2.03	0.88	2.83	2.03	0.88	2.83	2.03	0.88
19	2.99	2.24	0.97	2.99	2.24	0.97	2.99	2.24	0.97
20	3.15	2.46	1.07	3.15	2.46	1.07	3.15	2.46	1.07
25	3.94	3.72	1.61	3.94	3.72	1.61	3.94	3.72	1.61
30	4.72	5.22	2.26	4.72	5.22	2.26	4.72	5.22	2.26
35	5.51	6.94	3.01	5.51	6.94	3.01	5.51	6.94	3.01
40	6.30	8.89	3.85	6.30	8.89	3.85	6.30	8.89	3.85
45	7.08	11.05	4.78	7.08	11.05	4.78	7.08	11.05	4.78
50	7.87	13.43	5.81	7.87	13.43	5.81	7.87	13.43	5.81
55	8.66	16.02	6.94	8.66	16.02	6.94	8.66	16.02	6.94
60	9.45	18.81	8.15	9.45	18.81	8.15	9.45	18.81	8.15



VELOCITY, HEADLOSS & PRESSURE DROP VS. FLOW RATE

2" SDR 11	NIRON CLIMA <small>(middle layer with fiberglass)</small>			NIRON FG RED <small>(middle layer with fiberglass)</small>			NIRON BLUE NIRON MONO GREY		
	2 Inch Pipe <small>SDR 11, 2.48 inch OD, 2.03 inch ID</small>			2 Inch Pipe <small>SDR 11, 2.48 inch OD, 2.03 inch ID</small>			2 Inch Pipe <small>SDR 11, 2.48 inch OD, 2.03 inch ID</small>		
Flow (gpm)	Velocity (ft/sec)	Headloss (ft/100ft)	Δ P (psi/100ft)	Velocity (ft/sec)	Headloss (ft/100ft)	Δ P (psi/100ft)	Velocity (ft/sec)	Headloss (ft/100ft)	Δ P (psi/100ft)
10	0.99	0.22	0.10	0.99	0.22	0.10	0.99	0.22	0.10
11	1.09	0.26	0.11	1.09	0.26	0.11	1.09	0.26	0.11
12	1.19	0.31	0.13	1.19	0.31	0.13	1.19	0.31	0.13
13	1.29	0.36	0.16	1.29	0.36	0.16	1.29	0.36	0.16
14	1.39	0.41	0.18	1.39	0.41	0.18	1.39	0.41	0.18
15	1.49	0.47	0.20	1.49	0.47	0.20	1.49	0.47	0.20
20	1.98	0.80	0.35	1.98	0.80	0.35	1.98	0.80	0.35
25	2.48	1.21	0.52	2.48	1.21	0.52	2.48	1.21	0.52
30	2.97	1.69	0.73	2.97	1.69	0.73	2.97	1.69	0.73
35	3.47	2.25	0.98	3.47	2.25	0.98	3.47	2.25	0.98
40	3.97	2.88	1.25	3.97	2.88	1.25	3.97	2.88	1.25
45	4.46	3.59	1.55	4.46	3.59	1.55	4.46	3.59	1.55
50	4.96	4.36	1.89	4.96	4.36	1.89	4.96	4.36	1.89
55	5.45	5.20	2.25	5.45	5.20	2.25	5.45	5.20	2.25
60	5.95	6.10	2.64	5.95	6.10	2.64	5.95	6.10	2.64
65	6.45	7.08	3.07	6.45	7.08	3.07	6.45	7.08	3.07
70	6.94	8.12	3.52	6.94	8.12	3.52	6.94	8.12	3.52
75	7.44	9.22	3.99	7.44	9.22	3.99	7.44	9.22	3.99
80	7.93	10.39	4.50	7.93	10.39	4.50	7.93	10.39	4.50
85	8.43	11.63	5.04	8.43	11.63	5.04	8.43	11.63	5.04
90	8.92	12.93	5.60	8.92	12.93	5.60	8.92	12.93	5.60
100	9.92	15.71	6.80	9.92	15.71	6.80	9.92	15.71	6.80

VELOCITY, HEADLOSS & PRESSURE DROP VS. FLOW RATE

2½" SDR 11	NIRON CLIMA <small>(middle layer with fiberglass)</small>			NIRON FG RED <small>(middle layer with fiberglass)</small>			NIRON BLUE NIRON MONO GREY		
	2½ Inch Pipe <small>SDR 11, 2.95 inch OD, 2.42 inch ID</small>			2½ Inch Pipe <small>SDR 11, 2.95 inch OD, 2.42 inch ID</small>			2½ Inch Pipe <small>SDR 11, 2.95 inch OD, 2.42 inch ID</small>		
Flow (gpm)	Velocity (ft/sec)	Headloss (ft/100ft)	ΔP (psi/100ft)	Velocity (ft/sec)	Headloss (ft/100ft)	ΔP (psi/100ft)	Velocity (ft/sec)	Headloss (ft/100ft)	ΔP (psi/100ft)
10	0.70	0.09	0.04	0.70	0.09	0.04	0.70	0.09	0.04
11	0.77	0.11	0.05	0.77	0.11	0.05	0.77	0.11	0.05
12	0.84	0.13	0.06	0.84	0.13	0.06	0.84	0.13	0.06
13	0.91	0.15	0.07	0.91	0.15	0.07	0.91	0.15	0.07
14	0.98	0.18	0.08	0.98	0.18	0.08	0.98	0.18	0.08
15	1.05	0.20	0.09	1.05	0.20	0.09	1.05	0.20	0.09
20	1.40	0.34	0.15	1.40	0.34	0.15	1.40	0.34	0.15
25	1.75	0.52	0.22	1.75	0.52	0.22	1.75	0.52	0.22
30	2.10	0.72	0.31	2.10	0.72	0.31	2.10	0.72	0.31
35	2.45	0.96	0.42	2.45	0.96	0.42	2.45	0.96	0.42
40	2.80	1.23	0.53	2.80	1.23	0.53	2.80	1.23	0.53
50	3.50	1.86	0.81	3.50	1.86	0.81	3.50	1.86	0.81
60	4.20	2.61	1.13	4.20	2.61	1.13	4.20	2.61	1.13
70	4.90	3.47	1.50	4.90	3.47	1.50	4.90	3.47	1.50
80	5.60	4.45	1.93	5.60	4.45	1.93	5.60	4.45	1.93
90	6.30	5.53	2.39	6.30	5.53	2.39	6.30	5.53	2.39
100	7.00	6.72	2.91	7.00	6.72	2.91	7.00	6.72	2.91
110	7.70	8.02	3.47	7.70	8.02	3.47	7.70	8.02	3.47
120	8.40	9.41	4.08	8.40	9.41	4.08	8.40	9.41	4.08
130	9.10	10.92	4.73	9.10	10.92	4.73	9.10	10.92	4.73
140	9.80	12.52	5.42	9.80	12.52	5.42	9.80	12.52	5.42
150	10.49	14.23	6.16	10.49	14.23	6.16	10.49	14.23	6.16



VELOCITY, HEADLOSS & PRESSURE DROP VS. FLOW RATE

3" SDR 11	NIRON CLIMA <small>(middle layer with fiberglass)</small>			NIRON FG RED <small>(middle layer with fiberglass)</small>			NIRON BLUE NIRON MONO GREY		
	3 Inch Pipe <small>SDR 11, 3.54 inch OD, 2.90 inch ID</small>			3 Inch Pipe <small>SDR 11, 3.54 inch OD, 2.90 inch ID</small>			3 Inch Pipe <small>SDR 11, 3.54 inch OD, 2.90 inch ID</small>		
Flow (gpm)	Velocity (ft/sec)	Headloss (ft/100ft)	Δ P (psi/100ft)	Velocity (ft/sec)	Headloss (ft/100ft)	Δ P (psi/100ft)	Velocity (ft/sec)	Headloss (ft/100ft)	Δ P (psi/100ft)
20	0.97	0.14	0.06	0.97	0.14	0.06	0.97	0.14	0.06
21	1.02	0.15	0.07	1.02	0.15	0.07	1.02	0.15	0.07
22	1.07	0.17	0.07	1.07	0.17	0.07	1.07	0.17	0.07
23	1.12	0.18	0.08	1.12	0.18	0.08	1.12	0.18	0.08
24	1.17	0.20	0.09	1.17	0.20	0.09	1.17	0.20	0.09
25	1.21	0.21	0.09	1.21	0.21	0.09	1.21	0.21	0.09
30	1.46	0.30	0.13	1.46	0.30	0.13	1.46	0.30	0.13
35	1.70	0.40	0.17	1.70	0.40	0.17	1.70	0.40	0.17
40	1.94	0.51	0.22	1.94	0.51	0.22	1.94	0.51	0.22
45	2.19	0.63	0.27	2.19	0.63	0.27	2.19	0.63	0.27
50	2.43	0.77	0.33	2.43	0.77	0.33	2.43	0.77	0.33
60	2.92	1.07	0.47	2.92	1.07	0.47	2.92	1.07	0.47
70	3.40	1.43	0.62	3.40	1.43	0.62	3.40	1.43	0.62
80	3.89	1.83	0.79	3.89	1.83	0.79	3.89	1.83	0.79
90	4.37	2.28	0.99	4.37	2.28	0.99	4.37	2.28	0.99
100	4.86	2.77	1.20	4.86	2.77	1.20	4.86	2.77	1.20
110	5.34	3.30	1.43	5.34	3.30	1.43	5.34	3.30	1.43
120	5.83	3.87	1.68	5.83	3.87	1.68	5.83	3.87	1.68
140	6.80	5.15	2.23	6.80	5.15	2.23	6.80	5.15	2.23
160	7.77	6.60	2.86	7.77	6.60	2.86	7.77	6.60	2.86
180	8.75	8.20	3.55	8.75	8.20	3.55	8.75	8.20	3.55
200	9.72	9.97	4.32	9.72	9.97	4.32	9.72	9.97	4.32

VELOCITY, HEADLOSS & PRESSURE DROP VS. FLOW RATE

4" SDR 11	NIRON CLIMA <small>(middle layer with fiberglass)</small>			NIRON FG RED <small>(middle layer with fiberglass)</small>			NIRON BLUE NIRON MONO GREY		
	4 Inch Pipe <small>SDR 11, 4.33 inch OD, 3.54 inch ID</small>			4 Inch Pipe <small>SDR 11, 4.33 inch OD, 3.54 inch ID</small>			4 Inch Pipe <small>SDR 11, 4.33 inch OD, 3.54 inch ID</small>		
Flow (gpm)	Velocity (ft/sec)	Headloss (ft/100ft)	Δ P (psi/100ft)	Velocity (ft/sec)	Headloss (ft/100ft)	Δ P (psi/100ft)	Velocity (ft/sec)	Headloss (ft/100ft)	Δ P (psi/100ft)
30	0.98	0.11	0.05	0.98	0.11	0.05	0.98	0.11	0.05
35	1.14	0.15	0.06	1.14	0.15	0.06	1.14	0.15	0.06
40	1.30	0.19	0.08	1.30	0.19	0.08	1.30	0.19	0.08
50	1.63	0.29	0.12	1.63	0.29	0.12	1.63	0.29	0.12
60	1.95	0.40	0.18	1.95	0.40	0.18	1.95	0.40	0.18
70	2.28	0.54	0.23	2.28	0.54	0.23	2.28	0.54	0.23
80	2.60	0.69	0.30	2.60	0.69	0.30	2.60	0.69	0.30
90	2.93	0.86	0.37	2.93	0.86	0.37	2.93	0.86	0.37
100	3.25	1.04	0.45	3.25	1.04	0.45	3.25	1.04	0.45
120	3.90	1.46	0.63	3.90	1.46	0.63	3.90	1.46	0.63
140	4.55	1.94	0.84	4.55	1.94	0.84	4.55	1.94	0.84
160	5.20	2.48	1.08	5.20	2.48	1.08	5.20	2.48	1.08
180	5.85	3.09	1.34	5.85	3.09	1.34	5.85	3.09	1.34
200	6.51	3.75	1.62	6.51	3.75	1.62	6.51	3.75	1.62
220	7.16	4.47	1.94	7.16	4.47	1.94	7.16	4.47	1.94
240	7.81	5.26	2.28	7.81	5.26	2.28	7.81	5.26	2.28
260	8.46	6.10	2.64	8.46	6.10	2.64	8.46	6.10	2.64
280	9.11	6.99	3.03	9.11	6.99	3.03	9.11	6.99	3.03
290	9.43	7.46	3.23	9.43	7.46	3.23	9.43	7.46	3.23
300	9.76	7.94	3.44	9.76	7.94	3.44	9.76	7.94	3.44
310	10.08	8.44	3.65	10.08	8.44	3.65	10.08	8.44	3.65
320	10.41	8.95	3.88	10.41	8.95	3.88	10.41	8.95	3.88

VELOCITY, HEADLOSS & PRESSURE DROP VS. FLOW RATE

5" SDR 11	NIRON CLIMA <small>(middle layer with fiberglass)</small>			NIRON FG RED <small>(middle layer with fiberglass)</small>			NIRON BLUE NIRON MONO GREY		
	5 Inch Pipe <small>SDR 11, 4.92 inch OD, 4.03 inch ID</small>			5 Inch Pipe <small>SDR 11, 4.92 inch OD, 4.03 inch ID</small>			5 Inch Pipe <small>SDR 11, 4.92 inch OD, 4.03 inch ID</small>		
Flow (gpm)	Velocity (ft/sec)	Headloss (ft/100ft)	Δ P (psi/100ft)	Velocity (ft/sec)	Headloss (ft/100ft)	Δ P (psi/100ft)	Velocity (ft/sec)	Headloss (ft/100ft)	Δ P (psi/100ft)
40	1.01	0.10	0.04	1.01	0.10	0.04	1.01	0.10	0.04
50	1.26	0.15	0.07	1.26	0.15	0.07	1.26	0.15	0.07
60	1.51	0.22	0.09	1.51	0.22	0.09	1.51	0.22	0.09
70	1.76	0.29	0.12	1.76	0.29	0.12	1.76	0.29	0.12
80	2.02	0.37	0.16	2.02	0.37	0.16	2.02	0.37	0.16
90	2.27	0.46	0.20	2.27	0.46	0.20	2.27	0.46	0.20
100	2.52	0.56	0.24	2.52	0.56	0.24	2.52	0.56	0.24
110	2.77	0.67	0.29	2.77	0.67	0.29	2.77	0.67	0.29
120	3.02	0.78	0.34	3.02	0.78	0.34	3.02	0.78	0.34
130	3.27	0.91	0.39	3.27	0.91	0.39	3.27	0.91	0.39
140	3.53	1.04	0.45	3.53	1.04	0.45	3.53	1.04	0.45
150	3.78	1.18	0.51	3.78	1.18	0.51	3.78	1.18	0.51
175	4.41	1.57	0.68	4.41	1.57	0.68	4.41	1.57	0.68
200	5.04	2.01	0.87	5.04	2.01	0.87	5.04	2.01	0.87
225	5.67	2.50	1.08	5.67	2.50	1.08	5.67	2.50	1.08
250	6.30	3.04	1.32	6.30	3.04	1.32	6.30	3.04	1.32
275	6.93	3.63	1.57	6.93	3.63	1.57	6.93	3.63	1.57
300	7.56	4.26	1.85	7.56	4.26	1.85	7.56	4.26	1.85
325	8.19	4.94	2.14	8.19	4.94	2.14	8.19	4.94	2.14
350	8.82	5.67	2.45	8.82	5.67	2.45	8.82	5.67	2.45
375	9.45	6.44	2.79	9.45	6.44	2.79	9.45	6.44	2.79
400	10.08	7.26	3.14	10.08	7.26	3.14	10.08	7.26	3.14

VELOCITY, HEADLOSS & PRESSURE DROP VS. FLOW RATE

6" SDR 11	NIRON CLIMA <small>(middle layer with fiberglass)</small>			NIRON FG RED <small>(middle layer with fiberglass)</small>			NIRON BLUE NIRON MONO GREY		
	6 Inch Pipe <small>SDR 11, 6.30 inch OD, 5.15 inch ID</small>			6 Inch Pipe <small>SDR 11, 6.30 inch OD, 5.15 inch ID</small>			6 Inch Pipe <small>SDR 11, 6.30 inch OD, 5.15 inch ID</small>		
Flow (gpm)	Velocity (ft/sec)	Headloss (ft/100ft)	Δ P (psi/100ft)	Velocity (ft/sec)	Headloss (ft/100ft)	Δ P (psi/100ft)	Velocity (ft/sec)	Headloss (ft/100ft)	Δ P (psi/100ft)
75	1.15	0.10	0.04	1.15	0.10	0.04	1.15	0.10	0.04
100	1.54	0.17	0.07	1.54	0.17	0.07	1.54	0.17	0.07
125	1.92	0.25	0.11	1.92	0.25	0.11	1.92	0.25	0.11
150	2.31	0.36	0.15	2.31	0.36	0.15	2.31	0.36	0.15
175	2.69	0.47	0.20	2.69	0.47	0.20	2.69	0.47	0.20
200	3.07	0.60	0.26	3.07	0.60	0.26	3.07	0.60	0.26
225	3.46	0.75	0.33	3.46	0.75	0.33	3.46	0.75	0.33
250	3.84	0.91	0.40	3.84	0.91	0.40	3.84	0.91	0.40
275	4.23	1.09	0.47	4.23	1.09	0.47	4.23	1.09	0.47
300	4.61	1.28	0.55	4.61	1.28	0.55	4.61	1.28	0.55
325	5.00	1.49	0.64	5.00	1.49	0.64	5.00	1.49	0.64
350	5.38	1.70	0.74	5.38	1.70	0.74	5.38	1.70	0.74
375	5.77	1.94	0.84	5.77	1.94	0.84	5.77	1.94	0.84
400	6.15	2.18	0.94	6.15	2.18	0.94	6.15	2.18	0.94
425	6.53	2.44	1.06	6.53	2.44	1.06	6.53	2.44	1.06
450	6.92	2.71	1.17	6.92	2.71	1.17	6.92	2.71	1.17
475	7.30	3.00	1.30	7.30	3.00	1.30	7.30	3.00	1.30
500	7.69	3.30	1.43	7.69	3.30	1.43	7.69	3.30	1.43
550	8.46	3.93	1.70	8.46	3.93	1.70	8.46	3.93	1.70
600	9.22	4.62	2.00	9.22	4.62	2.00	9.22	4.62	2.00
650	9.99	5.35	2.32	9.99	5.35	2.32	9.99	5.35	2.32
700	10.76	6.14	2.66	10.76	6.14	2.66	10.76	6.14	2.66

VELOCITY, HEADLOSS & PRESSURE DROP VS. FLOW RATE

8" SDR 11	NIRON CLIMA <small>(middle layer with fiberglass)</small>			NIRON FG RED <small>(middle layer with fiberglass)</small>			NIRON BLUE NIRON MONO GREY		
	8 Inch Pipe <small>SDR 11, 7.87 inch OD, 6.44 inch ID</small>			8 Inch Pipe <small>SDR 11, 7.87 inch OD, 6.44 inch ID</small>			8 Inch Pipe <small>SDR 11, 7.87 inch OD, 6.44 inch ID</small>		
Flow (gpm)	Velocity (ft/sec)	Headloss (ft/100ft)	Δ P (psi/100ft)	Velocity (ft/sec)	Headloss (ft/100ft)	Δ P (psi/100ft)	Velocity (ft/sec)	Headloss (ft/100ft)	Δ P (psi/100ft)
100	0.98	0.06	0.02	0.98	0.06	0.02	0.98	0.06	0.02
120	1.18	0.08	0.03	1.18	0.08	0.03	1.18	0.08	0.03
140	1.38	0.11	0.05	1.38	0.11	0.05	1.38	0.11	0.05
160	1.57	0.14	0.06	1.57	0.14	0.06	1.57	0.14	0.06
200	1.97	0.20	0.09	1.97	0.20	0.09	1.97	0.20	0.09
225	2.21	0.25	0.11	2.21	0.25	0.11	2.21	0.25	0.11
250	2.46	0.31	0.13	2.46	0.31	0.13	2.46	0.31	0.13
300	2.95	0.43	0.19	2.95	0.43	0.19	2.95	0.43	0.19
350	3.44	0.57	0.25	3.44	0.57	0.25	3.44	0.57	0.25
400	3.94	0.74	0.32	3.94	0.74	0.32	3.94	0.74	0.32
450	4.43	0.91	0.40	4.43	0.91	0.40	4.43	0.91	0.40
500	4.92	1.11	0.48	4.92	1.11	0.48	4.92	1.11	0.48
550	5.41	1.33	0.57	5.41	1.33	0.57	5.41	1.33	0.57
600	5.90	1.56	0.67	5.90	1.56	0.67	5.90	1.56	0.67
650	6.40	1.81	0.78	6.40	1.81	0.78	6.40	1.81	0.78
700	6.89	2.07	0.90	6.89	2.07	0.90	6.89	2.07	0.90
750	7.38	2.35	1.02	7.38	2.35	1.02	7.38	2.35	1.02
800	7.87	2.65	1.15	7.87	2.65	1.15	7.87	2.65	1.15
850	8.36	2.97	1.28	8.36	2.97	1.28	8.36	2.97	1.28
900	8.86	3.30	1.43	8.86	3.30	1.43	8.86	3.30	1.43
950	9.35	3.64	1.58	9.35	3.64	1.58	9.35	3.64	1.58
1000	9.84	4.01	1.74	9.84	4.01	1.74	9.84	4.01	1.74

VELOCITY, HEADLOSS & PRESSURE DROP VS. FLOW RATE

10" SDR 11	NIRON CLIMA <small>(middle layer with fiberglass)</small>			NIRON FG RED <small>(middle layer with fiberglass)</small>			NIRON BLUE NIRON MONO GREY		
	10 Inch Pipe <small>SDR 11, 9.84 inch OD, 8.05 inch ID</small>			10 Inch Pipe <small>SDR 11, 9.84 inch OD, 8.05 inch ID</small>			10 Inch Pipe <small>SDR 11, 9.84 inch OD, 8.05 inch ID</small>		
Flow (gpm)	Velocity (ft/sec)	Headloss (ft/100ft)	Δ P (psi/100ft)	Velocity (ft/sec)	Headloss (ft/100ft)	Δ P (psi/100ft)	Velocity (ft/sec)	Headloss (ft/100ft)	Δ P (psi/100ft)
250	1.57	0.10	0.05	1.57	0.10	0.05	1.57	0.10	0.05
300	1.89	0.15	0.06	1.89	0.15	0.06	1.89	0.15	0.06
350	2.20	0.19	0.08	2.20	0.19	0.08	2.20	0.19	0.08
400	2.52	0.25	0.11	2.52	0.25	0.11	2.52	0.25	0.11
450	2.83	0.31	0.13	2.83	0.31	0.13	2.83	0.31	0.13
500	3.15	0.37	0.16	3.15	0.37	0.16	3.15	0.37	0.16
550	3.46	0.45	0.19	3.46	0.45	0.19	3.46	0.45	0.19
600	3.78	0.53	0.23	3.78	0.53	0.23	3.78	0.53	0.23
650	4.09	0.61	0.26	4.09	0.61	0.26	4.09	0.61	0.26
700	4.41	0.70	0.30	4.41	0.70	0.30	4.41	0.70	0.30
750	4.72	0.79	0.34	4.72	0.79	0.34	4.72	0.79	0.34
800	5.04	0.89	0.39	5.04	0.89	0.39	5.04	0.89	0.39
850	5.35	1.00	0.43	5.35	1.00	0.43	5.35	1.00	0.43
900	5.67	1.11	0.48	5.67	1.11	0.48	5.67	1.11	0.48
950	5.98	1.23	0.53	5.98	1.23	0.53	5.98	1.23	0.53
1000	6.30	1.35	0.59	6.30	1.35	0.59	6.30	1.35	0.59
1100	6.93	1.61	0.70	6.93	1.61	0.70	6.93	1.61	0.70
1200	7.56	1.89	0.82	7.56	1.89	0.82	7.56	1.89	0.82
1300	8.19	2.20	0.95	8.19	2.20	0.95	8.19	2.20	0.95
1400	8.82	2.52	1.09	8.82	2.52	1.09	8.82	2.52	1.09
1500	9.45	2.86	1.24	9.45	2.86	1.24	9.45	2.86	1.24
1600	10.08	3.23	1.40	10.08	3.23	1.40	10.08	3.23	1.40



VELOCITY, HEADLOSS & PRESSURE DROP VS. FLOW RATE

12" SDR 11	NIRON CLIMA <small>(middle layer with fiberglass)</small>			NIRON FG RED <small>(middle layer with fiberglass)</small>			NIRON BLUE NIRON MONO GREY		
	12 Inch Pipe <small>SDR 11, 12.40 inch OD, 10.15 inch ID</small>			12 Inch Pipe <small>SDR 11, 12.40 inch OD, 10.15 inch ID</small>			12 Inch Pipe <small>SDR 11, 12.40 inch OD, 10.15 inch ID</small>		
Flow (gpm)	Velocity (ft/sec)	Headloss (ft/100ft)	Δ P (psi/100ft)	Velocity (ft/sec)	Headloss (ft/100ft)	Δ P (psi/100ft)	Velocity (ft/sec)	Headloss (ft/100ft)	Δ P (psi/100ft)
300	1.19	0.05	0.02	1.19	0.05	0.02	1.19	0.05	0.02
400	1.59	0.08	0.03	1.59	0.08	0.03	1.59	0.08	0.03
500	1.98	0.12	0.05	1.98	0.12	0.05	1.98	0.12	0.05
600	2.38	0.17	0.07	2.38	0.17	0.07	2.38	0.17	0.07
700	2.78	0.23	0.10	2.78	0.23	0.10	2.78	0.23	0.10
800	3.17	0.29	0.13	3.17	0.29	0.13	3.17	0.29	0.13
900	3.57	0.36	0.16	3.57	0.36	0.16	3.57	0.36	0.16
1000	3.97	0.44	0.19	3.97	0.44	0.19	3.97	0.44	0.19
1200	4.76	0.61	0.27	4.76	0.61	0.27	4.76	0.61	0.27
1300	5.16	0.71	0.31	5.16	0.71	0.31	5.16	0.71	0.31
1400	5.55	0.82	0.35	5.55	0.82	0.35	5.55	0.82	0.35
1500	5.95	0.93	0.40	5.95	0.93	0.40	5.95	0.93	0.40
1600	6.35	1.05	0.45	6.35	1.05	0.45	6.35	1.05	0.45
1700	6.74	1.17	0.51	6.74	1.17	0.51	6.74	1.17	0.51
1800	7.14	1.30	0.56	7.14	1.30	0.56	7.14	1.30	0.56
1900	7.54	1.44	0.62	7.54	1.44	0.62	7.54	1.44	0.62
2000	7.93	1.58	0.68	7.93	1.58	0.68	7.93	1.58	0.68
2100	8.33	1.73	0.75	8.33	1.73	0.75	8.33	1.73	0.75
2200	8.73	1.89	0.82	8.73	1.89	0.82	8.73	1.89	0.82
2300	9.12	2.05	0.89	9.12	2.05	0.89	9.12	2.05	0.89
2400	9.52	2.22	0.96	9.52	2.22	0.96	9.52	2.22	0.96
2500	9.92	2.39	1.03	9.92	2.39	1.03	9.92	2.39	1.03

VELOCITY, HEADLOSS & PRESSURE DROP VS. FLOW RATE

14" SDR 11	NIRON CLIMA <small>(middle layer with fiberglass)</small>			NIRON FG RED <small>(middle layer with fiberglass)</small>			NIRON BLUE NIRON MONO GREY		
	14 Inch Pipe <small>SDR 11, 13.98 inch OD, 11.44 inch ID</small>			14 Inch Pipe <small>SDR 11, 13.98 inch OD, 11.44 inch ID</small>			14 Inch Pipe <small>SDR 11, 13.98 inch OD, 11.44 inch ID</small>		
Flow (gpm)	Velocity (ft/sec)	Headloss (ft/100ft)	Δ P (psi/100ft)	Velocity (ft/sec)	Headloss (ft/100ft)	Δ P (psi/100ft)	Velocity (ft/sec)	Headloss (ft/100ft)	Δ P (psi/100ft)
400	1.25	0.04	0.02	1.25	0.04	0.02	1.25	0.04	0.02
500	1.56	0.07	0.03	1.56	0.07	0.03	1.56	0.07	0.03
600	1.87	0.10	0.04	1.87	0.10	0.04	1.87	0.10	0.04
800	2.50	0.16	0.07	2.50	0.16	0.07	2.50	0.16	0.07
1000	3.12	0.25	0.11	3.12	0.25	0.11	3.12	0.25	0.11
1200	3.75	0.34	0.15	3.75	0.34	0.15	3.75	0.34	0.15
1400	4.37	0.46	0.20	4.37	0.46	0.20	4.37	0.46	0.20
1600	5.00	0.58	0.25	5.00	0.58	0.25	5.00	0.58	0.25
1800	5.62	0.73	0.31	5.62	0.73	0.31	5.62	0.73	0.31
2000	6.25	0.88	0.38	6.25	0.88	0.38	6.25	0.88	0.38
2100	6.56	0.97	0.42	6.56	0.97	0.42	6.56	0.97	0.42
2200	6.87	1.05	0.46	6.87	1.05	0.46	6.87	1.05	0.46
2300	7.18	1.14	0.50	7.18	1.14	0.50	7.18	1.14	0.50
2400	7.49	1.24	0.54	7.49	1.24	0.54	7.49	1.24	0.54
2500	7.81	1.33	0.58	7.81	1.33	0.58	7.81	1.33	0.58
2600	8.12	1.44	0.62	8.12	1.44	0.62	8.12	1.44	0.62
2700	8.43	1.54	0.67	8.43	1.54	0.67	8.43	1.54	0.67
2800	8.74	1.65	0.71	8.74	1.65	0.71	8.74	1.65	0.71
2900	9.06	1.76	0.76	9.06	1.76	0.76	9.06	1.76	0.76
3000	9.37	1.87	0.81	9.37	1.87	0.81	9.37	1.87	0.81
3100	9.68	1.99	0.86	9.68	1.99	0.86	9.68	1.99	0.86
3200	9.99	2.11	0.91	9.99	2.11	0.91	9.99	2.11	0.91



VELOCITY, HEADLOSS & PRESSURE DROP VS. FLOW RATE

16" SDR 11	NIRON CLIMA <small>(middle layer with fiberglass)</small>			NIRON FG RED <small>(middle layer with fiberglass)</small>			NIRON BLUE NIRON MONO GREY		
	16 Inch Pipe <small>SDR 11, 15.75 inch OD, 12.88 inch ID</small>			16 Inch Pipe <small>SDR 11, 15.75 inch OD, 12.88 inch ID</small>			16 Inch Pipe <small>SDR 11, 15.75 inch OD, 12.88 inch ID</small>		
Flow (gpm)	Velocity (ft/sec)	Headloss (ft/100ft)	Δ P (psi/100ft)	Velocity (ft/sec)	Headloss (ft/100ft)	Δ P (psi/100ft)	Velocity (ft/sec)	Headloss (ft/100ft)	Δ P (psi/100ft)
400	0.98	0.03	0.01	0.98	0.03	0.01	0.98	0.03	0.01
500	1.23	0.04	0.02	1.23	0.04	0.02	1.23	0.04	0.02
600	1.48	0.05	0.02	1.48	0.05	0.02	1.48	0.05	0.02
800	1.97	0.09	0.04	1.97	0.09	0.04	1.97	0.09	0.04
1000	2.46	0.14	0.06	2.46	0.14	0.06	2.46	0.14	0.06
1200	2.95	0.19	0.08	2.95	0.19	0.08	2.95	0.19	0.08
1400	3.44	0.26	0.11	3.44	0.26	0.11	3.44	0.26	0.11
1600	3.94	0.33	0.14	3.94	0.33	0.14	3.94	0.33	0.14
1800	4.43	0.41	0.18	4.43	0.41	0.18	4.43	0.41	0.18
2000	4.92	0.49	0.21	4.92	0.49	0.21	4.92	0.49	0.21
2200	5.41	0.59	0.26	5.41	0.59	0.26	5.41	0.59	0.26
2400	5.90	0.69	0.30	5.90	0.69	0.30	5.90	0.69	0.30
2600	6.40	0.80	0.35	6.40	0.80	0.35	6.40	0.80	0.35
2800	6.89	0.92	0.40	6.89	0.92	0.40	6.89	0.92	0.40
3000	7.38	1.05	0.45	7.38	1.05	0.45	7.38	1.05	0.45
3200	7.87	1.18	0.51	7.87	1.18	0.51	7.87	1.18	0.51
3400	8.36	1.32	0.57	8.36	1.32	0.57	8.36	1.32	0.57
3600	8.86	1.47	0.63	8.86	1.47	0.63	8.86	1.47	0.63
3800	9.35	1.62	0.70	9.35	1.62	0.70	9.35	1.62	0.70
4000	9.84	1.78	0.77	9.84	1.78	0.77	9.84	1.78	0.77
4200	10.33	1.95	0.84	10.33	1.95	0.84	10.33	1.95	0.84
4400	10.82	2.12	0.92	10.82	2.12	0.92	10.82	2.12	0.92

VELOCITY, HEADLOSS & PRESSURE DROP VS. FLOW RATE

2" SDR 17	NIRON CLIMA <small>(middle layer with fiberglass)</small>			NIRON FG RED <small>(middle layer with fiberglass)</small>			NIRON BLUE NIRON MONO GREY		
	2 Inch Pipe <small>SDR 17, 2.48 inch OD, 2.19 inch ID</small>			2 Inch Pipe <small>SDR 17, 2.48 inch OD, 2.19 inch ID</small>			2 Inch Pipe <small>SDR 17, 2.48 inch OD, 2.19 inch ID</small>		
Flow (gpm)	Velocity (ft/sec)	Headloss (ft/100ft)	Δ P (psi/100ft)	Velocity (ft/sec)	Headloss (ft/100ft)	Δ P (psi/100ft)	Velocity (ft/sec)	Headloss (ft/100ft)	Δ P (psi/100ft)
10	0.85	0.15	0.07	0.85	0.15	0.07	0.85	0.15	0.07
11	0.94	0.18	0.08	0.94	0.18	0.08	0.94	0.18	0.08
12	1.02	0.22	0.09	1.02	0.22	0.09	1.02	0.22	0.09
13	1.11	0.25	0.11	1.11	0.25	0.11	1.11	0.25	0.11
14	1.19	0.29	0.12	1.19	0.29	0.12	1.19	0.29	0.12
15	1.28	0.33	0.14	1.28	0.33	0.14	1.28	0.33	0.14
20	1.71	0.55	0.24	1.71	0.55	0.24	1.71	0.55	0.24
25	2.13	0.84	0.36	2.13	0.84	0.36	2.13	0.84	0.36
30	2.56	1.17	0.51	2.56	1.17	0.51	2.56	1.17	0.51
35	2.98	1.56	0.68	2.98	1.56	0.68	2.98	1.56	0.68
40	3.41	2.00	0.86	3.41	2.00	0.86	3.41	2.00	0.86
45	3.84	2.48	1.07	3.84	2.48	1.07	3.84	2.48	1.07
50	4.26	3.02	1.31	4.26	3.02	1.31	4.26	3.02	1.31
55	4.69	3.60	1.56	4.69	3.60	1.56	4.69	3.60	1.56
60	5.12	4.23	1.83	5.12	4.23	1.83	5.12	4.23	1.83
65	5.54	4.90	2.12	5.54	4.90	2.12	5.54	4.90	2.12
70	5.97	5.62	2.43	5.97	5.62	2.43	5.97	5.62	2.43
80	6.82	7.20	3.12	6.82	7.20	3.12	6.82	7.20	3.12
90	7.67	8.95	3.87	7.67	8.95	3.87	7.67	8.95	3.87
100	8.53	10.87	4.71	8.53	10.87	4.71	8.53	10.87	4.71
110	9.38	12.97	5.62	9.38	12.97	5.62	9.38	12.97	5.62
120	10.23	15.24	6.60	10.23	15.24	6.60	10.23	15.24	6.60



VELOCITY, HEADLOSS & PRESSURE DROP VS. FLOW RATE

2½" SDR 17	NIRON CLIMA <small>(middle layer with fiberglass)</small>			NIRON FG RED <small>(middle layer with fiberglass)</small>			NIRON BLUE NIRON MONO GREY		
	2½ Inch Pipe <small>SDR 17, 2.95 inch OD, 2.61 inch ID</small>			2½ Inch Pipe <small>SDR 17, 2.95 inch OD, 2.61 inch ID</small>			2½ Inch Pipe <small>SDR 17, 2.95 inch OD, 2.61 inch ID</small>		
Flow (gpm)	Velocity (ft/sec)	Headloss (ft/100ft)	ΔP (psi/100ft)	Velocity (ft/sec)	Headloss (ft/100ft)	ΔP (psi/100ft)	Velocity (ft/sec)	Headloss (ft/100ft)	ΔP (psi/100ft)
16	0.96	0.16	0.07	0.96	0.16	0.07	0.96	0.16	0.07
17	1.02	0.18	0.08	1.02	0.18	0.08	1.02	0.18	0.08
18	1.08	0.19	0.08	1.08	0.19	0.08	1.08	0.19	0.08
19	1.14	0.22	0.09	1.14	0.22	0.09	1.14	0.22	0.09
20	1.20	0.24	0.10	1.20	0.24	0.10	1.20	0.24	0.10
25	1.50	0.36	0.15	1.50	0.36	0.15	1.50	0.36	0.15
30	1.80	0.50	0.22	1.80	0.50	0.22	1.80	0.50	0.22
40	2.41	0.85	0.37	2.41	0.85	0.37	2.41	0.85	0.37
50	3.01	1.29	0.56	3.01	1.29	0.56	3.01	1.29	0.56
60	3.61	1.81	0.78	3.61	1.81	0.78	3.61	1.81	0.78
70	4.21	2.40	1.04	4.21	2.40	1.04	4.21	2.40	1.04
80	4.81	3.08	1.33	4.81	3.08	1.33	4.81	3.08	1.33
90	5.41	3.83	1.66	5.41	3.83	1.66	5.41	3.83	1.66
100	6.02	4.65	2.01	6.02	4.65	2.01	6.02	4.65	2.01
110	6.62	5.55	2.40	6.62	5.55	2.40	6.62	5.55	2.40
120	7.22	6.52	2.82	7.22	6.52	2.82	7.22	6.52	2.82
130	7.82	7.56	3.27	7.82	7.56	3.27	7.82	7.56	3.27
140	8.42	8.67	3.75	8.42	8.67	3.75	8.42	8.67	3.75
150	9.02	9.85	4.26	9.02	9.85	4.26	9.02	9.85	4.26
160	9.63	11.10	4.81	9.63	11.10	4.81	9.63	11.10	4.81
170	10.23	12.42	5.38	10.23	12.42	5.38	10.23	12.42	5.38
180	10.83	13.80	5.98	10.83	13.80	5.98	10.83	13.80	5.98

VELOCITY, HEADLOSS & PRESSURE DROP VS. FLOW RATE

3" SDR 17	NIRON CLIMA <small>(middle layer with fiberglass)</small>			NIRON FG RED <small>(middle layer with fiberglass)</small>			NIRON BLUE NIRON MONO GREY		
	3 Inch Pipe <small>SDR 17, 3.54 inch OD, 3.13 inch ID</small>			3 Inch Pipe <small>SDR 17, 3.54 inch OD, 3.13 inch ID</small>			3 Inch Pipe <small>SDR 17, 3.54 inch OD, 3.13 inch ID</small>		
Flow (gpm)	Velocity (ft/sec)	Headloss (ft/100ft)	Δ P (psi/100ft)	Velocity (ft/sec)	Headloss (ft/100ft)	Δ P (psi/100ft)	Velocity (ft/sec)	Headloss (ft/100ft)	Δ P (psi/100ft)
20	0.84	0.10	0.04	0.84	0.10	0.04	0.84	0.10	0.04
40	1.67	0.35	0.15	1.67	0.35	0.15	1.67	0.35	0.15
60	2.51	0.74	0.32	2.51	0.74	0.32	2.51	0.74	0.32
80	3.34	1.27	0.55	3.34	1.27	0.55	3.34	1.27	0.55
90	3.76	1.58	0.68	3.76	1.58	0.68	3.76	1.58	0.68
95	3.97	1.74	0.75	3.97	1.74	0.75	3.97	1.74	0.75
100	4.18	1.91	0.83	4.18	1.91	0.83	4.18	1.91	0.83
110	4.60	2.28	0.99	4.60	2.28	0.99	4.60	2.28	0.99
120	5.01	2.68	1.16	5.01	2.68	1.16	5.01	2.68	1.16
130	5.43	3.11	1.35	5.43	3.11	1.35	5.43	3.11	1.35
140	5.85	3.57	1.54	5.85	3.57	1.54	5.85	3.57	1.54
150	6.27	4.05	1.76	6.27	4.05	1.76	6.27	4.05	1.76
160	6.68	4.57	1.98	6.68	4.57	1.98	6.68	4.57	1.98
170	7.10	5.11	2.21	7.10	5.11	2.21	7.10	5.11	2.21
180	7.52	5.68	2.46	7.52	5.68	2.46	7.52	5.68	2.46
190	7.94	6.28	2.72	7.94	6.28	2.72	7.94	6.28	2.72
200	8.36	6.90	2.99	8.36	6.90	2.99	8.36	6.90	2.99
210	8.77	7.55	3.27	8.77	7.55	3.27	8.77	7.55	3.27
220	9.19	8.23	3.56	9.19	8.23	3.56	9.19	8.23	3.56
230	9.61	8.94	3.87	9.61	8.94	3.87	9.61	8.94	3.87
240	10.03	9.67	4.19	10.03	9.67	4.19	10.03	9.67	4.19
250	10.44	10.43	4.52	10.44	10.43	4.52	10.44	10.43	4.52



VELOCITY, HEADLOSS & PRESSURE DROP VS. FLOW RATE

4" SDR 17	NIRON CLIMA <small>(middle layer with fiberglass)</small>			NIRON FG RED <small>(middle layer with fiberglass)</small>			NIRON BLUE NIRON MONO GREY		
	4 Inch Pipe <small>SDR 17, 4.33 inch OD, 3.82 inch ID</small>			4 Inch Pipe <small>SDR 17, 4.33 inch OD, 3.82 inch ID</small>			4 Inch Pipe <small>SDR 17, 4.33 inch OD, 3.82 inch ID</small>		
Flow (gpm)	Velocity (ft/sec)	Headloss (ft/100ft)	Δ P (psi/100ft)	Velocity (ft/sec)	Headloss (ft/100ft)	Δ P (psi/100ft)	Velocity (ft/sec)	Headloss (ft/100ft)	Δ P (psi/100ft)
30	0.84	0.08	0.03	0.84	0.08	0.03	0.84	0.08	0.03
35	0.98	0.10	0.04	0.98	0.10	0.04	0.98	0.10	0.04
40	1.12	0.13	0.06	1.12	0.13	0.06	1.12	0.13	0.06
50	1.40	0.20	0.09	1.40	0.20	0.09	1.40	0.20	0.09
60	1.68	0.28	0.12	1.68	0.28	0.12	1.68	0.28	0.12
70	1.96	0.37	0.16	1.96	0.37	0.16	1.96	0.37	0.16
80	2.24	0.48	0.21	2.24	0.48	0.21	2.24	0.48	0.21
90	2.52	0.59	0.26	2.52	0.59	0.26	2.52	0.59	0.26
100	2.80	0.72	0.31	2.80	0.72	0.31	2.80	0.72	0.31
120	3.36	1.01	0.44	3.36	1.01	0.44	3.36	1.01	0.44
140	3.92	1.34	0.58	3.92	1.34	0.58	3.92	1.34	0.58
160	4.47	1.72	0.74	4.47	1.72	0.74	4.47	1.72	0.74
180	5.03	2.14	0.93	5.03	2.14	0.93	5.03	2.14	0.93
200	5.59	2.60	1.12	5.59	2.60	1.12	5.59	2.60	1.12
220	6.15	3.10	1.34	6.15	3.10	1.34	6.15	3.10	1.34
240	6.71	3.64	1.58	6.71	3.64	1.58	6.71	3.64	1.58
260	7.27	4.22	1.83	7.27	4.22	1.83	7.27	4.22	1.83
280	7.83	4.84	2.10	7.83	4.84	2.10	7.83	4.84	2.10
300	8.39	5.50	2.38	8.39	5.50	2.38	8.39	5.50	2.38
320	8.95	6.20	2.68	8.95	6.20	2.68	8.95	6.20	2.68
340	9.51	6.93	3.00	9.51	6.93	3.00	9.51	6.93	3.00
360	10.07	7.70	3.34	10.07	7.70	3.34	10.07	7.70	3.34

VELOCITY, HEADLOSS & PRESSURE DROP VS. FLOW RATE

5" SDR 17	NIRON CLIMA <small>(middle layer with fiberglass)</small>			NIRON FG RED <small>(middle layer with fiberglass)</small>			NIRON BLUE NIRON MONO GREY		
	5 Inch Pipe <small>SDR 17, 4.92 inch OD, 4.34 inch ID</small>			5 Inch Pipe <small>SDR 17, 4.92 inch OD, 4.34 inch ID</small>			5 Inch Pipe <small>SDR 17, 4.92 inch OD, 4.34 inch ID</small>		
Flow (gpm)	Velocity (ft/sec)	Headloss (ft/100ft)	Δ P (psi/100ft)	Velocity (ft/sec)	Headloss (ft/100ft)	Δ P (psi/100ft)	Velocity (ft/sec)	Headloss (ft/100ft)	Δ P (psi/100ft)
50	1.08	0.11	0.05	1.08	0.11	0.05	1.08	0.11	0.05
60	1.30	0.15	0.07	1.30	0.15	0.07	1.30	0.15	0.07
80	1.73	0.26	0.11	1.73	0.26	0.11	1.73	0.26	0.11
100	2.17	0.39	0.17	2.17	0.39	0.17	2.17	0.39	0.17
120	2.60	0.54	0.23	2.60	0.54	0.23	2.60	0.54	0.23
140	3.03	0.72	0.31	3.03	0.72	0.31	3.03	0.72	0.31
160	3.47	0.92	0.40	3.47	0.92	0.40	3.47	0.92	0.40
180	3.90	1.15	0.50	3.90	1.15	0.50	3.90	1.15	0.50
200	4.33	1.39	0.60	4.33	1.39	0.60	4.33	1.39	0.60
220	4.76	1.66	0.72	4.76	1.66	0.72	4.76	1.66	0.72
240	5.20	1.95	0.85	5.20	1.95	0.85	5.20	1.95	0.85
260	5.63	2.26	0.98	5.63	2.26	0.98	5.63	2.26	0.98
280	6.06	2.60	1.12	6.06	2.60	1.12	6.06	2.60	1.12
300	6.50	2.95	1.28	6.50	2.95	1.28	6.50	2.95	1.28
325	7.04	3.42	1.48	7.04	3.42	1.48	7.04	3.42	1.48
350	7.58	3.92	1.70	7.58	3.92	1.70	7.58	3.92	1.70
375	8.12	4.46	1.93	8.12	4.46	1.93	8.12	4.46	1.93
400	8.66	5.02	2.18	8.66	5.02	2.18	8.66	5.02	2.18
425	9.20	5.62	2.43	9.20	5.62	2.43	9.20	5.62	2.43
450	9.75	6.25	2.70	9.75	6.25	2.70	9.75	6.25	2.70
475	10.29	6.90	2.99	10.29	6.90	2.99	10.29	6.90	2.99
500	10.83	7.59	3.29	10.83	7.59	3.29	10.83	7.59	3.29

VELOCITY, HEADLOSS & PRESSURE DROP VS. FLOW RATE

6" SDR 17	NIRON CLIMA <small>(middle layer with fiberglass)</small>			NIRON FG RED <small>(middle layer with fiberglass)</small>			NIRON BLUE NIRON MONO GREY		
	6 Inch Pipe <small>SDR 17, 6.30 inch OD, 5.56 inch ID</small>			6 Inch Pipe <small>SDR 17, 6.30 inch OD, 5.56 inch ID</small>			6 Inch Pipe <small>SDR 17, 6.30 inch OD, 5.56 inch ID</small>		
Flow (gpm)	Velocity (ft/sec)	Headloss (ft/100ft)	Δ P (psi/100ft)	Velocity (ft/sec)	Headloss (ft/100ft)	Δ P (psi/100ft)	Velocity (ft/sec)	Headloss (ft/100ft)	Δ P (psi/100ft)
75	0.99	0.07	0.03	0.99	0.07	0.03	0.99	0.07	0.03
100	1.32	0.12	0.05	1.32	0.12	0.05	1.32	0.12	0.05
125	1.65	0.18	0.08	1.65	0.18	0.08	1.65	0.18	0.08
150	1.98	0.25	0.11	1.98	0.25	0.11	1.98	0.25	0.11
175	2.31	0.33	0.14	2.31	0.33	0.14	2.31	0.33	0.14
200	2.64	0.42	0.18	2.64	0.42	0.18	2.64	0.42	0.18
225	2.97	0.52	0.23	2.97	0.52	0.23	2.97	0.52	0.23
250	3.30	0.63	0.27	3.30	0.63	0.27	3.30	0.63	0.27
275	3.64	0.75	0.33	3.64	0.75	0.33	3.64	0.75	0.33
300	3.97	0.89	0.38	3.97	0.89	0.38	3.97	0.89	0.38
325	4.30	1.03	0.45	4.30	1.03	0.45	4.30	1.03	0.45
350	4.63	1.18	0.51	4.63	1.18	0.51	4.63	1.18	0.51
375	4.96	1.34	0.58	4.96	1.34	0.58	4.96	1.34	0.58
400	5.29	1.51	0.65	5.29	1.51	0.65	5.29	1.51	0.65
450	5.95	1.88	0.81	5.95	1.88	0.81	5.95	1.88	0.81
500	6.61	2.28	0.99	6.61	2.28	0.99	6.61	2.28	0.99
550	7.27	2.72	1.18	7.27	2.72	1.18	7.27	2.72	1.18
600	7.93	3.20	1.38	7.93	3.20	1.38	7.93	3.20	1.38
650	8.59	3.71	1.61	8.59	3.71	1.61	8.59	3.71	1.61
700	9.25	4.25	1.84	9.25	4.25	1.84	9.25	4.25	1.84
750	9.91	4.83	2.09	9.91	4.83	2.09	9.91	4.83	2.09
800	10.57	5.44	2.36	10.57	5.44	2.36	10.57	5.44	2.36

VELOCITY, HEADLOSS & PRESSURE DROP VS. FLOW RATE

8" SDR 17	NIRON CLIMA <small>(middle layer with fiberglass)</small>			NIRON FG RED <small>(middle layer with fiberglass)</small>			NIRON BLUE NIRON MONO GREY		
	8 Inch Pipe <small>SDR 17, 7.87 inch OD, 6.95 inch ID</small>			8 Inch Pipe <small>SDR 17, 7.87 inch OD, 6.95 inch ID</small>			8 Inch Pipe <small>SDR 17, 7.87 inch OD, 6.95 inch ID</small>		
Flow (gpm)	Velocity (ft/sec)	Headloss (ft/100ft)	Δ P (psi/100ft)	Velocity (ft/sec)	Headloss (ft/100ft)	Δ P (psi/100ft)	Velocity (ft/sec)	Headloss (ft/100ft)	Δ P (psi/100ft)
150	1.27	0.08	0.04	1.27	0.08	0.04	1.27	0.08	0.04
200	1.69	0.14	0.06	1.69	0.14	0.06	1.69	0.14	0.06
250	2.11	0.21	0.09	2.11	0.21	0.09	2.11	0.21	0.09
300	2.54	0.30	0.13	2.54	0.30	0.13	2.54	0.30	0.13
350	2.96	0.40	0.17	2.96	0.40	0.17	2.96	0.40	0.17
400	3.38	0.51	0.22	3.38	0.51	0.22	3.38	0.51	0.22
450	3.81	0.63	0.27	3.81	0.63	0.27	3.81	0.63	0.27
500	4.23	0.77	0.33	4.23	0.77	0.33	4.23	0.77	0.33
550	4.65	0.92	0.40	4.65	0.92	0.40	4.65	0.92	0.40
600	5.08	1.08	0.47	5.08	1.08	0.47	5.08	1.08	0.47
650	5.50	1.25	0.54	5.50	1.25	0.54	5.50	1.25	0.54
700	5.92	1.43	0.62	5.92	1.43	0.62	5.92	1.43	0.62
750	6.34	1.63	0.71	6.34	1.63	0.71	6.34	1.63	0.71
800	6.77	1.84	0.80	6.77	1.84	0.80	6.77	1.84	0.80
850	7.19	2.05	0.89	7.19	2.05	0.89	7.19	2.05	0.89
900	7.61	2.28	0.99	7.61	2.28	0.99	7.61	2.28	0.99
950	8.04	2.52	1.09	8.04	2.52	1.09	8.04	2.52	1.09
1000	8.46	2.77	1.20	8.46	2.77	1.20	8.46	2.77	1.20
1050	8.88	3.04	1.31	8.88	3.04	1.31	8.88	3.04	1.31
1100	9.31	3.31	1.43	9.31	3.31	1.43	9.31	3.31	1.43
1150	9.73	3.59	1.56	9.73	3.59	1.56	9.73	3.59	1.56
1200	10.15	3.89	1.68	10.15	3.89	1.68	10.15	3.89	1.68



VELOCITY, HEADLOSS & PRESSURE DROP VS. FLOW RATE

10" SDR 17	NIRON CLIMA <small>(middle layer with fiberglass)</small>			NIRON FG RED <small>(middle layer with fiberglass)</small>			NIRON BLUE NIRON MONO GREY		
	10 Inch Pipe <small>SDR 17, 9.84 inch OD, 8.68 inch ID</small>			10 Inch Pipe <small>SDR 17, 9.84 inch OD, 8.68 inch ID</small>			10 Inch Pipe <small>SDR 17, 9.84 inch OD, 8.68 inch ID</small>		
Flow (gpm)	Velocity (ft/sec)	Headloss (ft/100ft)	Δ P (psi/100ft)	Velocity (ft/sec)	Headloss (ft/100ft)	Δ P (psi/100ft)	Velocity (ft/sec)	Headloss (ft/100ft)	Δ P (psi/100ft)
250	1.35	0.07	0.03	1.35	0.07	0.03	1.35	0.07	0.03
300	1.62	0.10	0.04	1.62	0.10	0.04	1.62	0.10	0.04
350	1.90	0.13	0.06	1.90	0.13	0.06	1.90	0.13	0.06
400	2.17	0.17	0.07	2.17	0.17	0.07	2.17	0.17	0.07
450	2.44	0.21	0.09	2.44	0.21	0.09	2.44	0.21	0.09
500	2.71	0.26	0.11	2.71	0.26	0.11	2.71	0.26	0.11
550	2.98	0.31	0.13	2.98	0.31	0.13	2.98	0.31	0.13
600	3.25	0.36	0.16	3.25	0.36	0.16	3.25	0.36	0.16
700	3.79	0.48	0.21	3.79	0.48	0.21	3.79	0.48	0.21
800	4.33	0.62	0.27	4.33	0.62	0.27	4.33	0.62	0.27
900	4.87	0.77	0.33	4.87	0.77	0.33	4.87	0.77	0.33
1000	5.41	0.94	0.41	5.41	0.94	0.41	5.41	0.94	0.41
1100	5.96	1.12	0.48	5.96	1.12	0.48	5.96	1.12	0.48
1200	6.50	1.31	0.57	6.50	1.31	0.57	6.50	1.31	0.57
1300	7.04	1.52	0.66	7.04	1.52	0.66	7.04	1.52	0.66
1400	7.58	1.74	0.76	7.58	1.74	0.76	7.58	1.74	0.76
1500	8.12	1.98	0.86	8.12	1.98	0.86	8.12	1.98	0.86
1600	8.66	2.23	0.97	8.66	2.23	0.97	8.66	2.23	0.97
1700	9.20	2.50	1.08	9.20	2.50	1.08	9.20	2.50	1.08
1800	9.75	2.78	1.20	9.75	2.78	1.20	9.75	2.78	1.20
1900	10.29	3.07	1.33	10.29	3.07	1.33	10.29	3.07	1.33
2000	10.83	3.37	1.46	10.83	3.37	1.46	10.83	3.37	1.46

VELOCITY, HEADLOSS & PRESSURE DROP VS. FLOW RATE

12" SDR 17	NIRON CLIMA <small>(middle layer with fiberglass)</small>			NIRON FG RED <small>(middle layer with fiberglass)</small>			NIRON BLUE NIRON MONO GREY		
	12 Inch Pipe <small>SDR 17, 12.40 inch OD, 10.94 inch ID</small>			12 Inch Pipe <small>SDR 17, 12.40 inch OD, 10.94 inch ID</small>			12 Inch Pipe <small>SDR 17, 12.40 inch OD, 10.94 inch ID</small>		
Flow (gpm)	Velocity (ft/sec)	Headloss (ft/100ft)	Δ P (psi/100ft)	Velocity (ft/sec)	Headloss (ft/100ft)	Δ P (psi/100ft)	Velocity (ft/sec)	Headloss (ft/100ft)	Δ P (psi/100ft)
300	1.02	0.03	0.01	1.02	0.03	0.01	1.02	0.03	0.01
400	1.36	0.06	0.02	1.36	0.06	0.02	1.36	0.06	0.02
500	1.71	0.08	0.04	1.71	0.08	0.04	1.71	0.08	0.04
600	2.05	0.12	0.05	2.05	0.12	0.05	2.05	0.12	0.05
700	2.39	0.16	0.07	2.39	0.16	0.07	2.39	0.16	0.07
800	2.73	0.20	0.09	2.73	0.20	0.09	2.73	0.20	0.09
900	3.07	0.25	0.11	3.07	0.25	0.11	3.07	0.25	0.11
1000	3.41	0.30	0.13	3.41	0.30	0.13	3.41	0.30	0.13
1000	3.41	0.30	0.13	3.41	0.30	0.13	3.41	0.30	0.13
1100	3.75	0.36	0.16	3.75	0.36	0.16	3.75	0.36	0.16
1200	4.09	0.43	0.18	4.09	0.43	0.18	4.09	0.43	0.18
1300	4.43	0.49	0.21	4.43	0.49	0.21	4.43	0.49	0.21
1400	4.77	0.57	0.25	4.77	0.57	0.25	4.77	0.57	0.25
1500	5.12	0.64	0.28	5.12	0.64	0.28	5.12	0.64	0.28
1600	5.46	0.72	0.31	5.46	0.72	0.31	5.46	0.72	0.31
1700	5.80	0.81	0.35	5.80	0.81	0.35	5.80	0.81	0.35
1800	6.14	0.90	0.39	6.14	0.90	0.39	6.14	0.90	0.39
1900	6.48	1.00	0.43	6.48	1.00	0.43	6.48	1.00	0.43
2000	6.82	1.09	0.47	6.82	1.09	0.47	6.82	1.09	0.47
2500	8.53	1.65	0.72	8.53	1.65	0.72	8.53	1.65	0.72
2750	9.38	1.97	0.85	9.38	1.97	0.85	9.38	1.97	0.85
3000	10.23	2.32	1.00	10.23	2.32	1.00	10.23	2.32	1.00

VELOCITY, HEADLOSS & PRESSURE DROP VS. FLOW RATE

14" SDR 17	NIRON CLIMA <small>(middle layer with fiberglass)</small>			NIRON FG RED <small>(middle layer with fiberglass)</small>			NIRON BLUE NIRON MONO GREY		
	14 Inch Pipe <small>SDR 17, 13.98 inch OD, 12.33 inch ID</small>			14 Inch Pipe <small>SDR 17, 13.98 inch OD, 12.33 inch ID</small>			14 Inch Pipe <small>SDR 17, 13.98 inch OD, 12.33 inch ID</small>		
Flow (gpm)	Velocity (ft/sec)	Headloss (ft/100ft)	Δ P (psi/100ft)	Velocity (ft/sec)	Headloss (ft/100ft)	Δ P (psi/100ft)	Velocity (ft/sec)	Headloss (ft/100ft)	Δ P (psi/100ft)
400	1.07	0.03	0.01	1.07	0.03	0.01	1.07	0.03	0.01
500	1.34	0.05	0.02	1.34	0.05	0.02	1.34	0.05	0.02
600	1.61	0.07	0.03	1.61	0.07	0.03	1.61	0.07	0.03
800	2.15	0.11	0.05	2.15	0.11	0.05	2.15	0.11	0.05
1000	2.69	0.17	0.07	2.69	0.17	0.07	2.69	0.17	0.07
1200	3.22	0.24	0.10	3.22	0.24	0.10	3.22	0.24	0.10
1400	3.76	0.32	0.14	3.76	0.32	0.14	3.76	0.32	0.14
1600	4.30	0.40	0.18	4.30	0.40	0.18	4.30	0.40	0.18
1800	4.83	0.50	0.22	4.83	0.50	0.22	4.83	0.50	0.22
2000	5.37	0.61	0.26	5.37	0.61	0.26	5.37	0.61	0.26
2100	5.64	0.67	0.29	5.64	0.67	0.29	5.64	0.67	0.29
2200	5.91	0.73	0.32	5.91	0.73	0.32	5.91	0.73	0.32
2300	6.18	0.79	0.34	6.18	0.79	0.34	6.18	0.79	0.34
2400	6.44	0.86	0.37	6.44	0.86	0.37	6.44	0.86	0.37
2500	6.71	0.92	0.40	6.71	0.92	0.40	6.71	0.92	0.40
2600	6.98	0.99	0.43	6.98	0.99	0.43	6.98	0.99	0.43
2700	7.25	1.07	0.46	7.25	1.07	0.46	7.25	1.07	0.46
2800	7.52	1.14	0.49	7.52	1.14	0.49	7.52	1.14	0.49
2900	7.79	1.22	0.53	7.79	1.22	0.53	7.79	1.22	0.53
3000	8.06	1.29	0.56	8.06	1.29	0.56	8.06	1.29	0.56
3500	9.40	1.72	0.75	9.40	1.72	0.75	9.40	1.72	0.75
4000	10.74	2.20	0.95	10.74	2.20	0.95	10.74	2.20	0.95

VELOCITY, HEADLOSS & PRESSURE DROP VS. FLOW RATE

16" SDR 17	NIRON CLIMA <small>(middle layer with fiberglass)</small>			NIRON FG RED <small>(middle layer with fiberglass)</small>			NIRON BLUE NIRON MONO GREY		
	16 Inch Pipe <small>SDR 17, 15.75 inch OD, 13.90 inch ID</small>			16 Inch Pipe <small>SDR 17, 15.75 inch OD, 13.90 inch ID</small>			16 Inch Pipe <small>SDR 17, 15.75 inch OD, 13.90 inch ID</small>		
Flow (gpm)	Velocity (ft/sec)	Headloss (ft/100ft)	Δ P (psi/100ft)	Velocity (ft/sec)	Headloss (ft/100ft)	Δ P (psi/100ft)	Velocity (ft/sec)	Headloss (ft/100ft)	Δ P (psi/100ft)
400	0.85	0.02	0.01	0.85	0.02	0.01	0.85	0.02	0.01
500	1.06	0.03	0.01	1.06	0.03	0.01	1.06	0.03	0.01
600	1.27	0.04	0.02	1.27	0.04	0.02	1.27	0.04	0.02
800	1.69	0.06	0.03	1.69	0.06	0.03	1.69	0.06	0.03
1000	2.11	0.09	0.04	2.11	0.09	0.04	2.11	0.09	0.04
1200	2.54	0.13	0.06	2.54	0.13	0.06	2.54	0.13	0.06
1400	2.96	0.18	0.08	2.96	0.18	0.08	2.96	0.18	0.08
1600	3.38	0.23	0.10	3.38	0.23	0.10	3.38	0.23	0.10
1800	3.81	0.28	0.12	3.81	0.28	0.12	3.81	0.28	0.12
2000	4.23	0.34	0.15	4.23	0.34	0.15	4.23	0.34	0.15
2200	4.65	0.41	0.18	4.65	0.41	0.18	4.65	0.41	0.18
2400	5.08	0.48	0.21	5.08	0.48	0.21	5.08	0.48	0.21
2600	5.50	0.56	0.24	5.50	0.56	0.24	5.50	0.56	0.24
2800	5.92	0.64	0.28	5.92	0.64	0.28	5.92	0.64	0.28
3000	6.34	0.72	0.31	6.34	0.72	0.31	6.34	0.72	0.31
3200	6.77	0.82	0.35	6.77	0.82	0.35	6.77	0.82	0.35
3400	7.19	0.91	0.40	7.19	0.91	0.40	7.19	0.91	0.40
3600	7.61	1.01	0.44	7.61	1.01	0.44	7.61	1.01	0.44
3800	8.04	1.12	0.49	8.04	1.12	0.49	8.04	1.12	0.49
4000	8.46	1.23	0.53	8.46	1.23	0.53	8.46	1.23	0.53
4500	9.52	1.53	0.66	9.52	1.53	0.66	9.52	1.53	0.66
5000	10.57	1.86	0.81	10.57	1.86	0.81	10.57	1.86	0.81



VELOCITY, HEADLOSS & PRESSURE DROP VS. FLOW RATE

18" SDR 17	NIRON CLIMA <small>(middle layer with fiberglass)</small>			NIRON FG RED <small>(middle layer with fiberglass)</small>			NIRON BLUE NIRON MONO GREY		
	18 Inch Pipe <small>SDR 17, 17.87 inch OD, 15.63 inch ID</small>			18 Inch Pipe <small>SDR 17, 17.87 inch OD, 15.63 inch ID</small>			18 Inch Pipe <small>SDR 17, 17.87 inch OD, 15.63 inch ID</small>		
Flow (gpm)	Velocity (ft/sec)	Headloss (ft/100ft)	Δ P (psi/100ft)	Velocity (ft/sec)	Headloss (ft/100ft)	Δ P (psi/100ft)	Velocity (ft/sec)	Headloss (ft/100ft)	Δ P (psi/100ft)
700	1.17	0.03	0.01	1.17	0.03	0.01	1.17	0.03	0.01
800	1.34	0.04	0.02	1.34	0.04	0.02	1.34	0.04	0.02
900	1.50	0.04	0.02	1.50	0.04	0.02	1.50	0.04	0.02
1000	1.67	0.05	0.02	1.67	0.05	0.02	1.67	0.05	0.02
1200	2.01	0.07	0.03	2.01	0.07	0.03	2.01	0.07	0.03
1400	2.34	0.10	0.04	2.34	0.10	0.04	2.34	0.10	0.04
1600	2.67	0.13	0.06	2.67	0.13	0.06	2.67	0.13	0.06
1800	3.01	0.16	0.07	3.01	0.16	0.07	3.01	0.16	0.07
2000	3.34	0.19	0.08	3.34	0.19	0.08	3.34	0.19	0.08
2200	3.68	0.23	0.10	3.68	0.23	0.10	3.68	0.23	0.10
2400	4.01	0.27	0.12	4.01	0.27	0.12	4.01	0.27	0.12
2600	4.34	0.31	0.14	4.34	0.31	0.14	4.34	0.31	0.14
2800	4.68	0.36	0.16	4.68	0.36	0.16	4.68	0.36	0.16
3000	5.01	0.41	0.18	5.01	0.41	0.18	5.01	0.41	0.18
3200	5.35	0.46	0.20	5.35	0.46	0.20	5.35	0.46	0.20
3400	5.68	0.51	0.22	5.68	0.51	0.22	5.68	0.51	0.22
3600	6.02	0.57	0.25	6.02	0.57	0.25	6.02	0.57	0.25
3800	6.35	0.63	0.27	6.35	0.63	0.27	6.35	0.63	0.27
4000	6.68	0.69	0.30	6.68	0.69	0.30	6.68	0.69	0.30
4500	7.52	0.86	0.37	7.52	0.86	0.37	7.52	0.86	0.37
5500	9.19	1.25	0.54	9.19	1.25	0.54	9.19	1.25	0.54
6000	10.03	1.47	0.64	10.03	1.47	0.64	10.03	1.47	0.64

VELOCITY, HEADLOSS & PRESSURE DROP VS. FLOW RATE

20" SDR 17	NIRON CLIMA <small>(middle layer with fiberglass)</small>			NIRON FG RED <small>(middle layer with fiberglass)</small>			NIRON BLUE NIRON MONO GREY		
	20 Inch Pipe <small>SDR 17, 19.69 inch OD, 17.37 inch ID</small>			20 Inch Pipe <small>SDR 17, 19.69 inch OD, 17.37 inch ID</small>			20 Inch Pipe <small>SDR 17, 19.69 inch OD, 17.37 inch ID</small>		
Flow (gpm)	Velocity (ft/sec)	Headloss (ft/100ft)	Δ P (psi/100ft)	Velocity (ft/sec)	Headloss (ft/100ft)	Δ P (psi/100ft)	Velocity (ft/sec)	Headloss (ft/100ft)	Δ P (psi/100ft)
700	0.95	0.02	0.01	0.95	0.02	0.01	0.95	0.02	0.01
800	1.08	0.02	0.01	1.08	0.02	0.01	1.08	0.02	0.01
900	1.22	0.03	0.01	1.22	0.03	0.01	1.22	0.03	0.01
1000	1.35	0.03	0.01	1.35	0.03	0.01	1.35	0.03	0.01
1200	1.62	0.04	0.02	1.62	0.04	0.02	1.62	0.04	0.02
1400	1.90	0.06	0.03	1.90	0.06	0.03	1.90	0.06	0.03
1600	2.17	0.08	0.03	2.17	0.08	0.03	2.17	0.08	0.03
1800	2.44	0.09	0.04	2.44	0.09	0.04	2.44	0.09	0.04
2000	2.71	0.12	0.05	2.71	0.12	0.05	2.71	0.12	0.05
2250	3.05	0.14	0.06	3.05	0.14	0.06	3.05	0.14	0.06
2500	3.38	0.17	0.08	3.38	0.17	0.08	3.38	0.17	0.08
2750	3.72	0.21	0.09	3.72	0.21	0.09	3.72	0.21	0.09
3000	4.06	0.24	0.11	4.06	0.24	0.11	4.06	0.24	0.11
3500	4.74	0.32	0.14	4.74	0.32	0.14	4.74	0.32	0.14
4000	5.41	0.42	0.18	5.41	0.42	0.18	5.41	0.42	0.18
4500	6.09	0.52	0.22	6.09	0.52	0.22	6.09	0.52	0.22
5000	6.77	0.63	0.27	6.77	0.63	0.27	6.77	0.63	0.27
5500	7.44	0.75	0.32	7.44	0.75	0.32	7.44	0.75	0.32
6000	8.12	0.88	0.38	8.12	0.88	0.38	8.12	0.88	0.38
6500	8.80	1.02	0.44	8.80	1.02	0.44	8.80	1.02	0.44
7000	9.48	1.17	0.51	9.48	1.17	0.51	9.48	1.17	0.51
7500	10.15	1.33	0.58	10.15	1.33	0.58	10.15	1.33	0.58

VELOCITY, HEADLOSS & PRESSURE DROP VS. FLOW RATE

18" SDR 17	NIRON CLIMA <small>(middle layer with fiberglass)</small>			NIRON FG RED <small>(middle layer with fiberglass)</small>			NIRON BLUE NIRON MONO GREY		
	18 Inch Pipe <small>SDR 17, 17.87 inch OD, 15.63 inch ID</small>			18 Inch Pipe <small>SDR 17, 17.87 inch OD, 15.63 inch ID</small>			18 Inch Pipe <small>SDR 17, 17.87 inch OD, 15.63 inch ID</small>		
Flow (gpm)	Velocity (ft/sec)	Headloss (ft/100ft)	Δ P (psi/100ft)	Velocity (ft/sec)	Headloss (ft/100ft)	Δ P (psi/100ft)	Velocity (ft/sec)	Headloss (ft/100ft)	Δ P (psi/100ft)
700	1.17	0.03	0.01	1.17	0.03	0.01	1.17	0.03	0.01
800	1.34	0.04	0.02	1.34	0.04	0.02	1.34	0.04	0.02
900	1.50	0.04	0.02	1.50	0.04	0.02	1.50	0.04	0.02
1000	1.67	0.05	0.02	1.67	0.05	0.02	1.67	0.05	0.02
1200	2.01	0.07	0.03	2.01	0.07	0.03	2.01	0.07	0.03
1400	2.34	0.10	0.04	2.34	0.10	0.04	2.34	0.10	0.04
1600	2.67	0.13	0.06	2.67	0.13	0.06	2.67	0.13	0.06
1800	3.01	0.16	0.07	3.01	0.16	0.07	3.01	0.16	0.07
2000	3.34	0.19	0.08	3.34	0.19	0.08	3.34	0.19	0.08
2200	3.68	0.23	0.10	3.68	0.23	0.10	3.68	0.23	0.10
2400	4.01	0.27	0.12	4.01	0.27	0.12	4.01	0.27	0.12
2600	4.34	0.31	0.14	4.34	0.31	0.14	4.34	0.31	0.14
2800	4.68	0.36	0.16	4.68	0.36	0.16	4.68	0.36	0.16
3000	5.01	0.41	0.18	5.01	0.41	0.18	5.01	0.41	0.18
3200	5.35	0.46	0.20	5.35	0.46	0.20	5.35	0.46	0.20
3400	5.68	0.51	0.22	5.68	0.51	0.22	5.68	0.51	0.22
3600	6.02	0.57	0.25	6.02	0.57	0.25	6.02	0.57	0.25
3800	6.35	0.63	0.27	6.35	0.63	0.27	6.35	0.63	0.27
4000	6.68	0.69	0.30	6.68	0.69	0.30	6.68	0.69	0.30
4500	7.52	0.86	0.37	7.52	0.86	0.37	7.52	0.86	0.37
5500	9.19	1.25	0.54	9.19	1.25	0.54	9.19	1.25	0.54
6000	10.03	1.47	0.64	10.03	1.47	0.64	10.03	1.47	0.64

VELOCITY, HEADLOSS & PRESSURE DROP VS. FLOW RATE

20" SDR 17	NIRON CLIMA <small>(middle layer with fiberglass)</small>			NIRON FG RED <small>(middle layer with fiberglass)</small>			NIRON BLUE NIRON MONO GREY		
	20 Inch Pipe <small>SDR 17, 19.69 inch OD, 17.37 inch ID</small>			20 Inch Pipe <small>SDR 17, 19.69 inch OD, 17.37 inch ID</small>			20 Inch Pipe <small>SDR 17, 19.69 inch OD, 17.37 inch ID</small>		
Flow (gpm)	Velocity (ft/sec)	Headloss (ft/100ft)	Δ P (psi/100ft)	Velocity (ft/sec)	Headloss (ft/100ft)	Δ P (psi/100ft)	Velocity (ft/sec)	Headloss (ft/100ft)	Δ P (psi/100ft)
700	0.95	0.02	0.01	0.95	0.02	0.01	0.95	0.02	0.01
800	1.08	0.02	0.01	1.08	0.02	0.01	1.08	0.02	0.01
900	1.22	0.03	0.01	1.22	0.03	0.01	1.22	0.03	0.01
1000	1.35	0.03	0.01	1.35	0.03	0.01	1.35	0.03	0.01
1200	1.62	0.04	0.02	1.62	0.04	0.02	1.62	0.04	0.02
1400	1.90	0.06	0.03	1.90	0.06	0.03	1.90	0.06	0.03
1600	2.17	0.08	0.03	2.17	0.08	0.03	2.17	0.08	0.03
1800	2.44	0.09	0.04	2.44	0.09	0.04	2.44	0.09	0.04
2000	2.71	0.12	0.05	2.71	0.12	0.05	2.71	0.12	0.05
2250	3.05	0.14	0.06	3.05	0.14	0.06	3.05	0.14	0.06
2500	3.38	0.17	0.08	3.38	0.17	0.08	3.38	0.17	0.08
2750	3.72	0.21	0.09	3.72	0.21	0.09	3.72	0.21	0.09
3000	4.06	0.24	0.11	4.06	0.24	0.11	4.06	0.24	0.11
3500	4.74	0.32	0.14	4.74	0.32	0.14	4.74	0.32	0.14
4000	5.41	0.42	0.18	5.41	0.42	0.18	5.41	0.42	0.18
4500	6.09	0.52	0.22	6.09	0.52	0.22	6.09	0.52	0.22
5000	6.77	0.63	0.27	6.77	0.63	0.27	6.77	0.63	0.27
5500	7.44	0.75	0.32	7.44	0.75	0.32	7.44	0.75	0.32
6000	8.12	0.88	0.38	8.12	0.88	0.38	8.12	0.88	0.38
6500	8.80	1.02	0.44	8.80	1.02	0.44	8.80	1.02	0.44
7000	9.48	1.17	0.51	9.48	1.17	0.51	9.48	1.17	0.51
7500	10.15	1.33	0.58	10.15	1.33	0.58	10.15	1.33	0.58



VELOCITY, HEADLOSS & PRESSURE DROP VS. FLOW RATE

22" SDR 17	NIRON CLIMA <small>(middle layer with fiberglass)</small>			NIRON FG RED <small>(middle layer with fiberglass)</small>			NIRON BLUE NIRON MONO GREY		
	22 Inch Pipe <small>SDR 17, 22.05 inch OD, 19.45 inch ID</small>			22 Inch Pipe <small>SDR 17, 22.05 inch OD, 19.45 inch ID</small>			22 Inch Pipe <small>SDR 17, 22.05 inch OD, 19.45 inch ID</small>		
Flow (gpm)	Velocity (ft/sec)	Headloss (ft/100ft)	ΔP (psi/100ft)	Velocity (ft/sec)	Headloss (ft/100ft)	ΔP (psi/100ft)	Velocity (ft/sec)	Headloss (ft/100ft)	ΔP (psi/100ft)
800	0.86	0.01	0.01	0.86	0.01	0.01	0.86	0.01	0.01
900	0.97	0.02	0.01	0.97	0.02	0.01	0.97	0.02	0.01
1000	1.08	0.02	0.01	1.08	0.02	0.01	1.08	0.02	0.01
1200	1.29	0.03	0.01	1.29	0.03	0.01	1.29	0.03	0.01
1400	1.51	0.03	0.01	1.51	0.03	0.01	1.51	0.03	0.01
1600	1.73	0.04	0.02	1.73	0.04	0.02	1.73	0.04	0.02
1800	1.94	0.05	0.02	1.94	0.05	0.02	1.94	0.05	0.02
2000	2.16	0.07	0.03	2.16	0.07	0.03	2.16	0.07	0.03
2250	2.43	0.08	0.04	2.43	0.08	0.04	2.43	0.08	0.04
2500	2.70	0.10	0.04	2.70	0.10	0.04	2.70	0.10	0.04
2750	2.97	0.12	0.05	2.97	0.12	0.05	2.97	0.12	0.05
3000	3.24	0.14	0.06	3.24	0.14	0.06	3.24	0.14	0.06
3250	3.51	0.16	0.07	3.51	0.16	0.07	3.51	0.16	0.07
3500	3.78	0.19	0.08	3.78	0.19	0.08	3.78	0.19	0.08
3750	4.05	0.21	0.09	4.05	0.21	0.09	4.05	0.21	0.09
4000	4.32	0.24	0.10	4.32	0.24	0.10	4.32	0.24	0.10
5000	5.40	0.36	0.16	5.40	0.36	0.16	5.40	0.36	0.16
6000	6.47	0.51	0.22	6.47	0.51	0.22	6.47	0.51	0.22
7000	7.55	0.67	0.29	7.55	0.67	0.29	7.55	0.67	0.29
8000	8.63	0.86	0.37	8.63	0.86	0.37	8.63	0.86	0.37
9000	9.71	1.07	0.46	9.71	1.07	0.46	9.71	1.07	0.46
10000	10.79	1.30	0.56	10.79	1.30	0.56	10.79	1.30	0.56









VELOCITY, HEADLOSS & PRESSURE DROP VS. FLOW RATE

24" SDR 17	NIRON CLIMA <small>(middle layer with fiberglass)</small>			NIRON FG RED <small>(middle layer with fiberglass)</small>			NIRON BLUE NIRON MONO GREY		
	24 Inch Pipe <small>SDR 17, 24.8 inch OD, 21.89 inch ID</small>			24 Inch Pipe <small>SDR 17, 24.8 inch OD, 21.89 inch ID</small>			24 Inch Pipe <small>SDR 17, 24.8 inch OD, 21.89 inch ID</small>		
Flow (gpm)	Velocity (ft/sec)	Headloss (ft/100ft)	Δ P (psi/100ft)	Velocity (ft/sec)	Headloss (ft/100ft)	Δ P (psi/100ft)	Velocity (ft/sec)	Headloss (ft/100ft)	Δ P (psi/100ft)
1100	0.94	0.01	0.01	0.94	0.01	0.01	0.94	0.01	0.01
1200	1.02	0.01	0.01	1.02	0.01	0.01	1.02	0.01	0.01
1300	1.11	0.02	0.01	1.11	0.02	0.01	1.11	0.02	0.01
1400	1.19	0.02	0.01	1.19	0.02	0.01	1.19	0.02	0.01
1600	1.36	0.02	0.01	1.36	0.02	0.01	1.36	0.02	0.01
1800	1.53	0.03	0.01	1.53	0.03	0.01	1.53	0.03	0.01
2000	1.71	0.04	0.02	1.71	0.04	0.02	1.71	0.04	0.02
2250	1.92	0.05	0.02	1.92	0.05	0.02	1.92	0.05	0.02
2500	2.13	0.06	0.02	2.13	0.06	0.02	2.13	0.06	0.02
2750	2.34	0.07	0.03	2.34	0.07	0.03	2.34	0.07	0.03
3000	2.56	0.08	0.03	2.56	0.08	0.03	2.56	0.08	0.03
4000	3.41	0.13	0.06	3.41	0.13	0.06	3.41	0.13	0.06
5000	4.26	0.20	0.09	4.26	0.20	0.09	4.26	0.20	0.09
6000	5.12	0.29	0.12	5.12	0.29	0.12	5.12	0.29	0.12
7000	5.97	0.38	0.16	5.97	0.38	0.16	5.97	0.38	0.16
8000	6.82	0.49	0.21	6.82	0.49	0.21	6.82	0.49	0.21
9000	7.67	0.60	0.26	7.67	0.60	0.26	7.67	0.60	0.26
10000	8.53	0.74	0.32	8.53	0.74	0.32	8.53	0.74	0.32
11000	9.38	0.88	0.38	9.38	0.88	0.38	9.38	0.88	0.38
12000	10.23	1.03	0.45	10.23	1.03	0.45	10.23	1.03	0.45
13000	11.08	1.19	0.52	11.08	1.19	0.52	11.08	1.19	0.52
14000	11.94	1.37	0.59	11.94	1.37	0.59	11.94	1.37	0.59

4.7 FITTING EQUIVALENT LENGTHS

EQUIVALENT LENGTHS OF PIPE FOR VARIOUS FITTINGS (ft.)

Socket		Tee Through main		Tee Through branch		Tee Conjunction of flow		Tee Counter current flow separation		Tee Counter current flow conjunction		Reducer By 1 dimension	
													
3/8" 16 mm	.04	3/8" 16 mm	.04	3/8" 16 mm	2.1	3/8" 16 mm	1.4	3/8" 16 mm	3.1	3/8" 16 mm	5.2	3/8" 16 mm	
1/2" 20 mm	.05	1/2" 20 mm	.05	1/2" 20 mm	2.6	1/2" 20 mm	1.7	1/2" 20 mm	3.9	1/2" 20 mm	6.5	1/2" 20 mm	0.9
3/4" 25 mm	.07	3/4" 25 mm	.07	3/4" 25 mm	3.3	3/4" 25 mm	2.2	3/4" 25 mm	4.9	3/4" 25 mm	8.2	3/4" 25 mm	1.1
1" 32 mm	.09	1" 32 mm	.09	1" 32 mm	4.2	1" 32 mm	2.8	1" 32 mm	6.3	1" 32 mm	10.4	1" 32 mm	1.4
1 1/4" 40 mm	1.1	1 1/4" 40 mm	1.1	1 1/4" 40 mm	5.2	1 1/4" 40 mm	3.5	1 1/4" 40 mm	7.9	1 1/4" 40 mm	13.1	1 1/4" 40 mm	1.7
1 1/2" 50 mm	1.4	1 1/2" 50 mm	1.4	1 1/2" 50 mm	6.6	1 1/2" 50 mm	4.4	1 1/2" 50 mm	9.9	1 1/2" 50 mm	16.4	1 1/2" 50 mm	2.2
2" 63 mm	1.7	2" 63 mm	1.7	2" 63 mm	8.3	2" 63 mm	5.5	2" 63 mm	12.4	2" 63 mm	20.7	2" 63 mm	2.8
2 1/2" 75 mm	2.1	2 1/2" 75 mm	2.1	2 1/2" 75 mm	9.8	2 1/2" 75 mm	6.6	2 1/2" 75 mm	14.8	2 1/2" 75 mm	24.6	2 1/2" 75 mm	3.3
3" 90 mm	2.5	3" 90 mm	2.5	3" 90 mm	11.8	3" 90 mm	7.9	3" 90 mm	17.7	3" 90 mm	29.5	3" 90 mm	3.9
4" 110 mm	3.0	4" 110 mm	3.0	4" 110 mm	14.4	4" 110 mm	9.6	4" 110 mm	21.7	4" 110 mm	36.1	4" 110 mm	4.8
5" 125 mm	4.2	5" 125 mm	4.2	5" 125 mm	20.1	5" 125 mm	13.4	5" 125 mm	30.2	5" 125 mm	50.3	5" 125 mm	6.7
		6" 200 mm	5.4	6" 200 mm	25.8	6" 200 mm	17.2	6" 200 mm	38.7	6" 200 mm	64.4	6" 200 mm	8.6
		8" 200mm	6.7	8" 200mm	32.2	8" 200mm	21.5	8" 200mm	48.3	8" 200mm	80.5	8" 200mm	10.7
		10" 250 mm	8.4	10" 250 mm	40.3	10" 250 mm	26.8	10" 250 mm	60.4	10" 250 mm	100.7	10" 250 mm	13.4
		12" 315 mm	10.6	12" 315 mm	50.7	12" 315 mm	33.8	12" 315 mm	76.1	12" 315 mm	126.9	12" 315 mm	16.9
		14" 355 mm	11.9	14" 355 mm	57.2	14" 355 mm	38.1	14" 355 mm	85.8	14" 355 mm	143.0	14" 355 mm	19.1

EQUIVALENT LENGTHS OF PIPE FOR VARIOUS FITTINGS (ft.)

Reducer By 2 dimensions		Reducer By 3 dimensions		Reducer By 4 dimensions		Reducer By 5 dimensions		Reducer By 6 dimensions		Cross Separation of flow		Cross Conjunction of flow	
3/8" 16 mm		3/8" 16 mm		3/8" 16 mm		3/8" 16 mm		3/8" 16 mm		3/8" 16 mm	3.7	3/8" 16 mm	6.4
1/2" 20 mm		1/2" 20 mm		1/2" 20 mm		1/2" 20 mm		1/2" 20 mm		1/2" 20 mm	4.5	1/2" 20 mm	8.0
3/4" 25 mm	1.4	3/4" 25 mm		3/4" 25 mm		3/4" 25 mm		3/4" 25 mm		3/4" 25 mm	5.7	3/4" 25 mm	10.1
1" 32 mm	1.7	1" 32 mm	2.1	1" 32 mm		1" 32 mm		1" 32 mm		1" 32 mm	7.3	1" 32 mm	12.9
1 1/4" 40 mm	2.2	1 1/4" 40 mm	2.6	1 1/4" 40 mm	3.1	1 1/4" 40 mm		1 1/4" 40 mm		1 1/4" 40 mm	9.2	1 1/4" 40 mm	16.1
1 1/2" 50 mm	2.7	1 1/2" 50 mm	3.3	1 1/2" 50 mm	3.8	1 1/2" 50 mm	4.4	1 1/2" 50 mm					
2" 63 mm	3.4	2" 63 mm	4.1	2" 63 mm	4.8	2" 63 mm	5.5	2" 63 mm	6.2				
2 1/2" 75 mm	4.1	2 1/2" 75 mm	4.9	2 1/2" 75 mm	5.7	2 1/2" 75 mm	6.6	2 1/2" 75 mm	7.4				
3" 90 mm	4.9	3" 90 mm	5.9	3" 90 mm	6.9	3" 90 mm	7.9	3" 90 mm	8.9				
4" 110 mm	6.0	4" 110 mm	7.2	4" 110 mm	8.4	4" 110 mm	9.6	4" 110 mm	10.8				
5" 125 mm	8.4	5" 125 mm	10.1	5" 125 mm	11.7	5" 125 mm	13.4	5" 125 mm	15.1				
6" 160 mm	10.7	6" 200 mm	12.9	6" 160 mm	15.0	6" 160 mm	17.2	6" 160 mm	19.3				
8" 200mm	13.4	8" 200mm	16.1	8" 200mm	18.8	8" 200mm	21.5	8" 200mm	24.2				
10" 250 mm	16.8	10" 250 mm	20.1	10" 250 mm	23.5	10" 250 mm	26.8	10" 250 mm	30.2				
12" 315 mm	21.1	12" 315 mm	25.4	12" 315 mm	29.6	12" 315 mm	33.8	12" 315 mm	38.1				
14" 355 mm	23.8	14" 355 mm	28.6	14" 355 mm	33.4	14" 355 mm	33.4	14" 355 mm	42.9				

EQUIVALENT LENGTHS OF PIPE FOR VARIOUS FITTINGS (ft.)

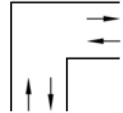
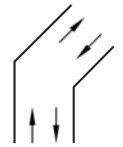
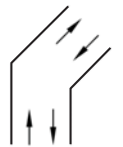
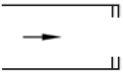
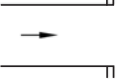
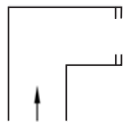
Elbow 90°		Elbow 90° Street		Elbow 45°		Elbow 45° Street		Adapter Female thread		Adapter Male thread		Elbow Female thread	
													
3/8" 16 mm	1.3	3/8" 16 mm	1.3	3/8" 16 mm	0.7	3/8" 16 mm	0.7	3/8" 16 mm	0.9	3/8" 16 mm	1.2	3/8" 16 mm	1.5
1/2" 20 mm	1.6	1/2" 20 mm	1.6	1/2" 20 mm	0.9	1/2" 20 mm	0.9	1/2" 20 mm	1.1	1/2" 20 mm	1.5	1/2" 20 mm	1.9
3/4" 25 mm	2.0	3/4" 25 mm	2.0	3/4" 25 mm	1.1	3/4" 25 mm	1.1	3/4" 25 mm	1.4	3/4" 25 mm	1.9	3/4" 25 mm	2.4
1" 32 mm	2.6	1" 32 mm	2.6	1" 32 mm	1.4	1" 32 mm	1.4	1" 32 mm	1.7	1" 32 mm	2.4	1" 32 mm	3.0
1 1/4" 40 mm	3.3	1 1/4" 40 mm	3.3	1 1/4" 40 mm	1.7	1 1/4" 40 mm	1.7	1 1/4" 40 mm	2.2	1 1/4" 40 mm	3.1		
1 1/2" 50 mm	4.1			1 1/2" 50 mm	2.2			1 1/2" 50 mm	2.7	1 1/2" 50 mm	3.8		
2" 63 mm	5.2			2" 63 mm	2.8			2" 63 mm	3.4	2" 63 mm	4.8		
2 1/2" 75 mm	6.2			2 1/2" 75 mm	3.3			2 1/2" 75 mm	4.1	2 1/2" 75 mm	5.7		
3" 90 mm	7.4			3" 90 mm	3.9					3" 90 mm	6.9		
4" 110 mm	9.0			4" 110 mm	4.8					4" 110 mm	8.4		
5" 125 mm	12.6			5" 125 mm	6.7								
6" 160 mm	17.2			6" 200 mm	8.6								
8" 200mm	21.5			8" 200mm	10.7								
10" 250 mm	26.9			10" 250 mm	13.4								
12" 315 mm	33.8			12" 315 mm	16.9								
14" 355 mm	38.1			14" 355 mm	19.1								

EQUIVALENT LENGTHS OF PIPE FOR VARIOUS FITTINGS (ft.)

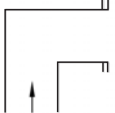
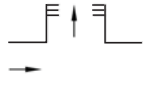
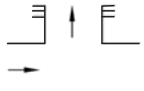
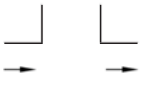
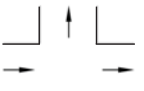
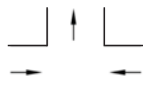
Elbow Male thread		Tee Female thread		Tee Male thread		Saddle Reducer Through main		Saddle Reducer Through branch		Saddle Reducer Combination of flow			
													
$\frac{3}{8}$ " 16 mm	1.7	$\frac{3}{8}$ " 16 mm	2.8	$\frac{3}{8}$ " 16 mm		$\frac{3}{8}$ " 16 mm	0.4	$\frac{3}{8}$ " 16 mm	0.9	$\frac{3}{8}$ " 16 mm	1.7		
$\frac{1}{2}$ " 20 mm	2.2	$\frac{1}{2}$ " 20 mm	3.5	$\frac{1}{2}$ " 20 mm	3.9	$\frac{1}{2}$ " 20 mm	0.5	$\frac{1}{2}$ " 20 mm	1.1	$\frac{1}{2}$ " 20 mm	2.2		
$\frac{3}{4}$ " 25 mm	2.7	$\frac{3}{4}$ " 25 mm	4.4			$\frac{3}{4}$ " 25 mm	0.7	$\frac{3}{4}$ " 25 mm	1.4	$\frac{3}{4}$ " 25 mm	2.7		
1" 32 mm	3.5	1" 32 mm	5.6			1" 32 mm	0.9	1" 32 mm	1.7	1" 32 mm	3.5		
						$1\frac{1}{4}$ " 40 mm	1.1	$1\frac{1}{4}$ " 40 mm	2.2	$1\frac{1}{4}$ " 40 mm	4.4		
						$1\frac{1}{2}$ " 50 mm	1.4	$1\frac{1}{2}$ " 50 mm	2.7	$1\frac{1}{2}$ " 50 mm	5.5		
						2" 63 mm	1.7	2" 63 mm	3.4	2" 63 mm	6.9		
						$2\frac{1}{2}$ " 75 mm	2.1	$2\frac{1}{2}$ " 75 mm	4.1	$2\frac{1}{2}$ " 75 mm	8.2		
						3" 90 mm	2.5	3" 90 mm	4.9	3" 90 mm	9.8		
						4" 110 mm	3.0	4" 110 mm	6.0	4" 110 mm	12.0		
						5" 125 mm	4.2	5" 125 mm	8.4	5" 125 mm	16.8		
						6" 160 mm	5.4	6" 160 mm	10.7	6" 160 mm	21.5		
						8" 200 mm	6.7	8" 200 mm	13.4	8" 200 mm	26.8		
						10" 250 mm	8.4	10" 250 mm	16.8	10" 250 mm	33.6		
						12" 315 mm	10.6	12" 315 mm	21.1	12" 315 mm	42.3		
						14" 355 mm	11.9	14" 355 mm	23.8	14" 355 mm	47.7		

EQUIVALENT LENGTHS OF PIPE FOR INTERNAL BUTT FUSION WELD BEADS (ft.)

SIZE	SIZE	DR	MAX BEAD inches	EQUIVALENT LENGTH feet of pipe
1¼	40	7.3	0.07	0.52
1½	50	7.3	0.09	0.8
2	63	7.3	0.11	1
2½	75	7.3	0.13	1.2
3	90	7.3	0.16	1.6
4	110	7.3	0.20	2.2
5	125	7.3	0.22	2.9
6	160	7.3	0.29	3.5
8	200	7.3	0.36	4.5
10	250	7.3	0.45	6
12	315	7.3	0.57	8
14	355	7.3	0.64	9
16	400	7.3	0.72	10
18	450	7.3	0.81	12
20	500	7.3	0.90	13
22	560	7.3	1.01	15
24	630	7.3	1.13	16
1¼	40	9	0.06	0.4
1½	50	9	0.07	0.6
2	63	9	0.09	0.75
2½	75	9	0.11	1
3	90	9	0.13	1.25
4	110	9	0.16	1.5
5	125	9	0.18	2
6	160	9	0.23	2.5
8	200	9	0.29	3
10	250	9	0.36	4
12	315	9	0.46	6
14	355	9	0.52	7
16	400	9	0.58	8
18	450	9	0.66	9
20	500	9	0.73	10

SIZE	SIZE	DR	MAX BEAD inches	EQUIVALENT LENGTH feet of pipe
1¼	40	11	0.05	0.3
1½	50	11	0.06	0.5
2	63	11	0.08	0.7
2½	75	11	0.09	0.9
3	90	11	0.11	1.2
4	110	11	0.13	1.5
5	125	11	0.15	1.8
6	160	11	0.19	2.3
8	200	11	0.24	3
10	250	11	0.30	4
12	315	11	0.38	5
14	355	11	0.42	6
16	400	11	0.48	7
18	450	11	0.54	8
20	500	11	0.60	9
22	560	11	0.67	10
24	630	11	0.75	12
2	63	17	0.05	0.5
2½	75	17	0.06	0.7
3	90	17	0.07	0.8
4	110	17	0.08	1
5	125	17	0.10	1.2
6	160	17	0.12	1.4
8	200	17	0.15	1.8
10	250	17	0.19	2.4
12	315	17	0.24	3
14	355	17	0.27	4
16	400	17	0.31	4.5
18	450	17	0.35	5
20	500	17	0.39	6
22	560	17	0.43	7
24	630	17	0.49	8

4.8 SYSTEM TESTING

The testing of Niron piping systems should be carried out through **hydrostatic or pneumatic testing. Hydrostatic testing is outlined as follows:**

- 1** Fill the system slowly to vent it (do not fully tighten the highest plugs to be closed until water comes out with a continuous jet).
- 2** Bring the pressure up to the test pressure. The test pressure should be a minimum of 1.5 times the design pressure of the system, or alternatively up to 220 psi. Note that thermoplastic pipes such as Niron PP-RCT pipes will expand upon initially pressurizing them. For that reason, the pressure should be increased two (2) more times every 10 minutes.
- 3** Measure the pressure after the first 30 minutes.
- 4** Read the pressure after another 30 minutes (one hour from the end of step 2). If the difference is less than or equal to 3.5% of the pressure measured after the 2nd re-pressurization step (the pressure measured at the 30 minute mark after initial pressurization), then the actual "1 hour test" can be started from this pressure point. During this time, the system should be visually inspected to determine if there are visual leaks noted.
- 5** After the one (1) hour test, the maximum pressure drop must be 1.5% or less from the pressure point when the one hour test was started.
- 6** If there are no leaks, and the pressure drop in step 5 is less than 1.5% (i.e. no more than 5% overall from the 30 minute mark), the test is considered to have passing results. The results of this test shall be recorded.
- 7** As an example, the initial test pressure is 220psi. After ten minutes, the system drops to 210 psi and is repressurized to 220 psi (@ the 10 minute mark). After another ten minutes, it drops again to 212 psi and is repressurized again to 220 psi (@ the 20 minute mark). Then after ten additional minutes (@ the 30 minute mark), the pressure recorded is 214 psi. Since this is less than a 3% drop from the pressure measured at the 30 minute mark, the one hour test can then be started. After 60 minutes from the start, the final pressure recorded is 212 psi with no leaks (i.e. less than a 1% drop in pressure). This was a successful test.

NOTE

NIRON systems can be tested with compressed air in lieu of water at the sole risk of the installing contractor (Nupi Americas does not assume or accept any liability based on the decision by the installing contractor to test with compressed air). When considering an air test, special precautions must be taken due to the inherent dangers of testing with compressed air. Please refer to Nupi Americas' printed recommendations for performing air testing and be sure to follow all local and national safety regulations in order to minimize the dangers due to compressed air testing.

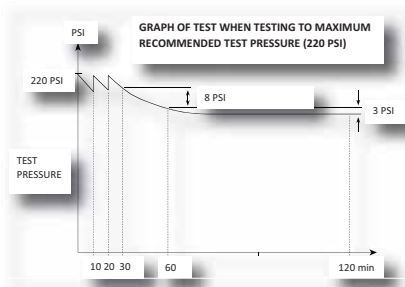
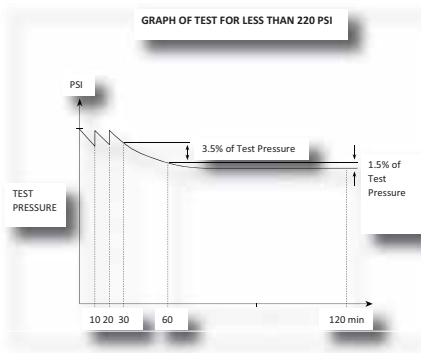

WARNING

Testing pressure shall be reduced to the maximum pressure rating of the lowest rated element of the system, which is often components other than the NIRON components, if these lower rated components can not be isolated during testing.

4.9 CHEMICAL COMPATABILITY OF NIRON PP-RCT

For chemical compatibility of polypropylene material make reference to: **PPI-TR19** '*Chemical Resistance of Thermoplastics Piping Materials*' (available for free download from the website www.plasticpipe.org) and to **ISO TR 10358** '*Plastics pipes and fittings - Combined chemical resistance classification table*'.

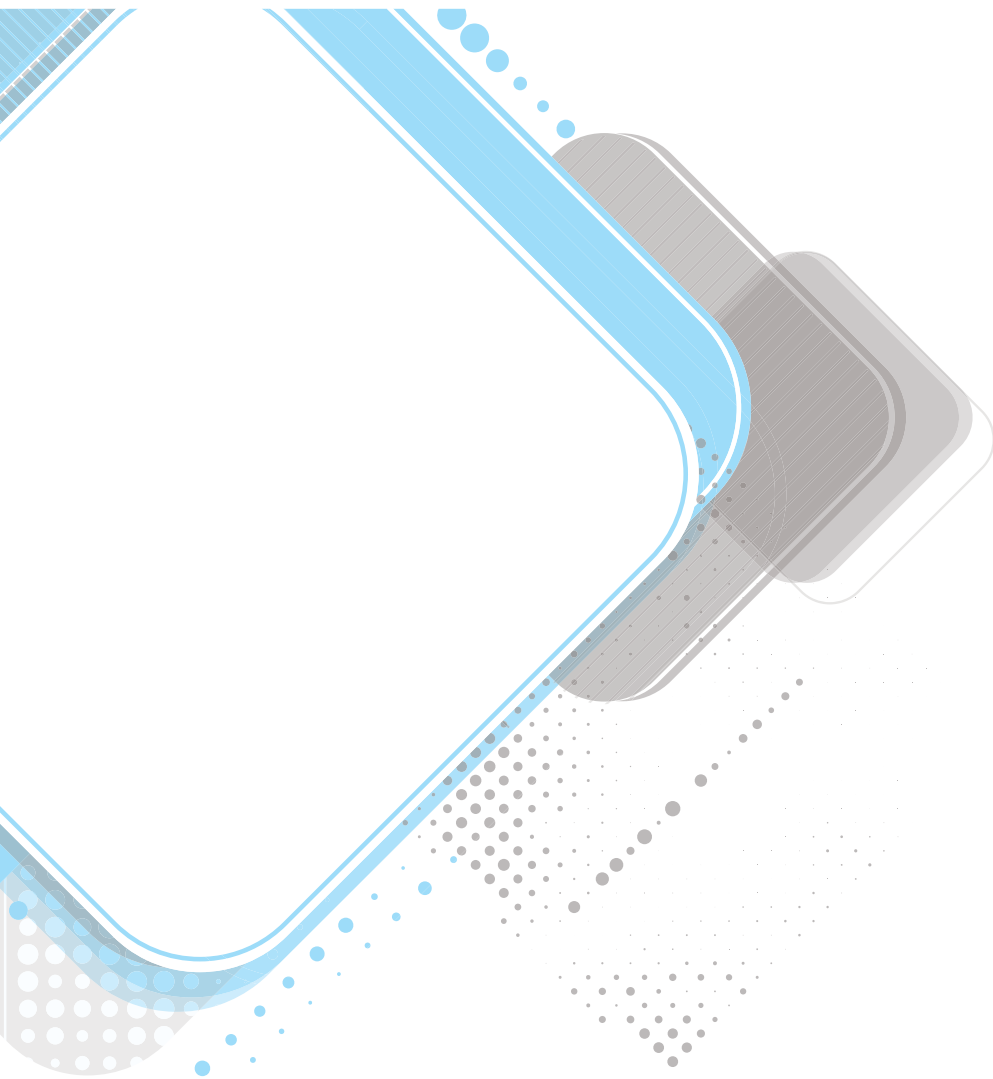

Nupi Americas, Inc.

1511 Superior Way,
Houston - TX 77039 - U.S.A.
ph. +1 281 590 4471
fax +1 281 590 5268

314 Commerce Parkway
Early Branch - SC 29916 - U.S.A.
ph. +1 803-398-3579
fax: +1 803 398 3639

info@nupiamericas.com
www.nupiamericas.com

