

Newdeal LUBRICATOR

Lubricator with high lubrication stability.

- Quantity of lubricant proportioned to air flow
- Micrometric regulation of lubricant flow
- Activates at low flow rates
- All-round oil level viewing



TECHNICAL DATA	LUB ND 1/4"	LUB ND 3/8"	LUB ND 1/2"	LUB ND 3/4"	LUB ND 1"
Threaded port	1/4"	3/8"	1/2"	3/4"	1"
Type of lubrication	mist				
Bowl capacity	50	150	380		
Max. inlet pressure	1.8 MPa - 18 bar - 261 psi				
Flow rate at 6.3 bar (0.63 MPa ÷ 91 psi)	700	3000	12800		
ΔP 0.5 bar (0.05 MPa ÷ 7 psi)	25	107	452		
Flow rate at 6.3 bar (0.63 MPa ÷ 91 psi)	1100	4300	16000		
ΔP 1 bar (0.1 MPa ÷ 14 psi)	39	153	565		
Fluid	Filtered compressed air				
Max temperature at 1 MPa; 10 bar; 145 psi	50°C - 122°F				
Weight	0.4	0.9	1.3		
Wall fixing screws	M4x40	M4x55	M6x75		
Mounting position	Vertical				
Notes:	<ul style="list-style-type: none"> • Use the screw provided to set the drip rate to drop every 300-600 NI. • Fit the lubricator as close as possible to the point of use • Fill the bowl with oil before pressurizing the system • Do not use cleaning oil, brake fluid or solvents in general • Recommended lubricants: ISO and UNI FD22 - E.g. Energol HLP 22 (BP) - Spinesso 22 (Esso) - Mobil DTE 22 (Mobil) - Tellus Oil 22 (Shell) 				
On request:	<ul style="list-style-type: none"> • Automatic filling lubricator and minimum level lubricator. 				

COMPONENTS:

- ① Zamak body
- ② Rilsan oil suction pipe
- ③ Aluminium bowl
- ④ Clear technopolymer bowl
- ⑤ Filter
- ⑥ Technopolymer plug
- ⑦ Venturi NBR diaphragm
- ⑧ OT 58 brass oil flow regulation needle
- ⑨ Clear technopolymer cover
- ⑩ NBR gaskets

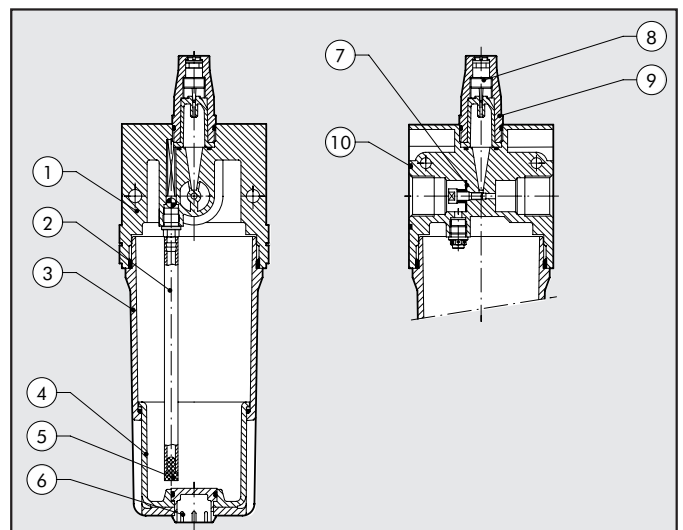

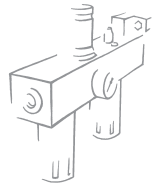

FLOW CHARTS

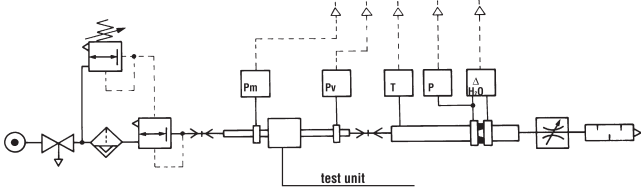

• Flow tests carried out at the Department of Mechanics, Turin Polytechnic, using the computerized test bench following CETOP RP50R recommendations (ISO DIS 6358-2-approved) with ISO 5167 diaphragm gauge.

- (A) = 2 bar - 0,2 MPa - 29 psi
- (B) = 4 bar - 0,4 MPa - 58 psi
- (C) = 6 bar - 0,6 MPa - 87 psi
- (D) = 8 bar - 0,8 MPa - 116 psi
- (E) = 10 bar - 1 MPa - 145 psi

LUB 1/4

$\Delta P = (P_m - P_v)$
psi KPa bar

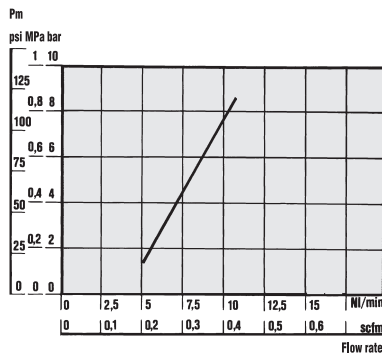
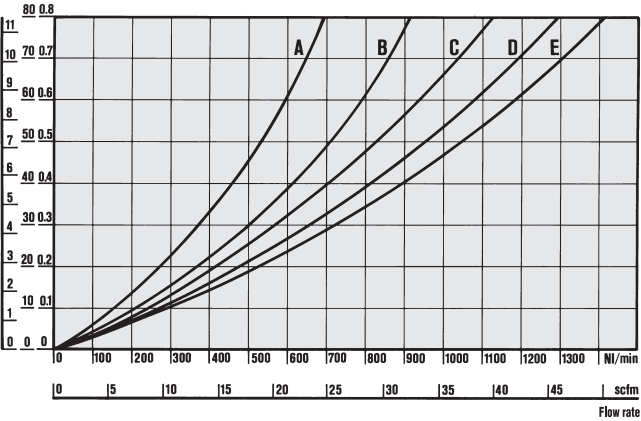

• MINIMUM ACTIVATION FLOW CHARTS

The minimum activation flow charts were carried out in compliance with ISO/DP 6301/2

LUB 3/8 - 1/2

$\Delta P = (P_m - P_v)$
psi KPa bar

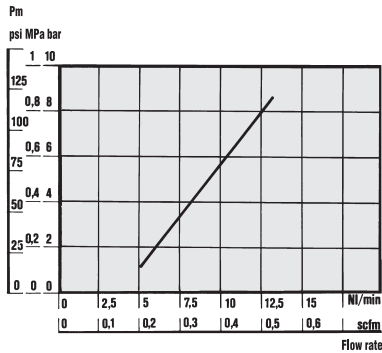
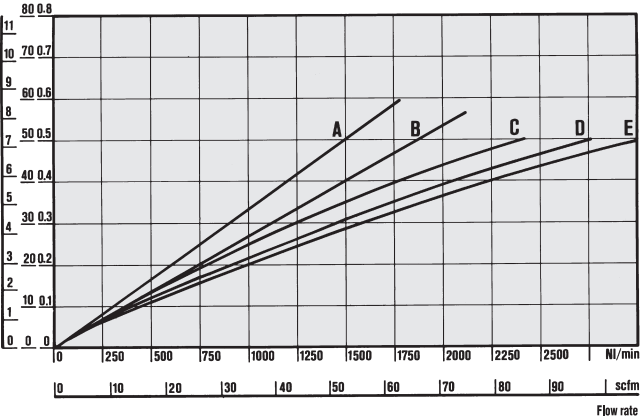

• MINIMUM ACTIVATION FLOW CHARTS

The minimum activation flow charts were carried out in compliance with ISO/DP 6301/2

LUB 3/4 - 1"

$\Delta P = (P_m - P_v)$
psi KPa bar

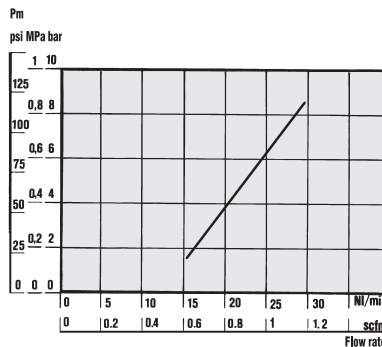
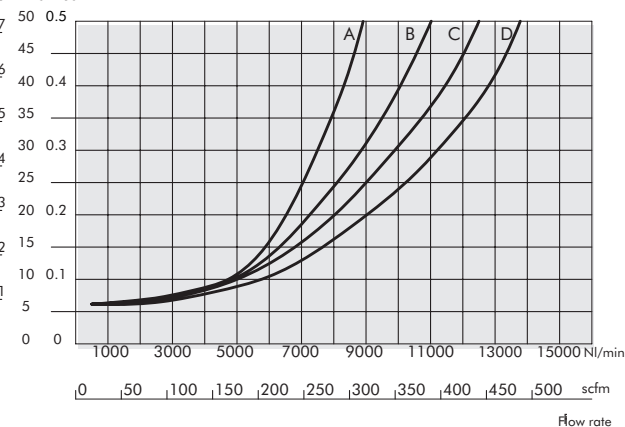

• MINIMUM ACTIVATION FLOW CHARTS

The minimum activation flow charts were carried out in compliance with ISO/DP 6301/2

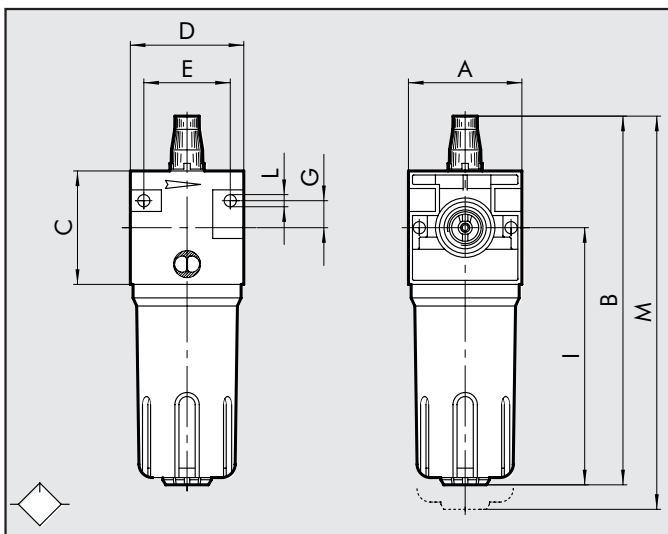
DIMENSIONS

	G 1/4	G 3/8	G 1/2	G 3/4	G 1"
A	42	60			80
B	156	195			260
C	42	60			80
D	42	60			80
E	32	46			66
G	10	14			22
I	107	136			182
L	M4 hole	M4 hole			M6 hole
M	176	220			290

ORDERING CODES

Code	Description
1223001	LUB 1/4 N TMV
1323001	LUB 3/8 N TMV
1423001	LUB 1/2 N TMV
1523001	LUB 3/4 N TMV
1623001	LUB 1 N TMV

NOTES

Blank area for notes.