

DRAWING NO.
AL 102040

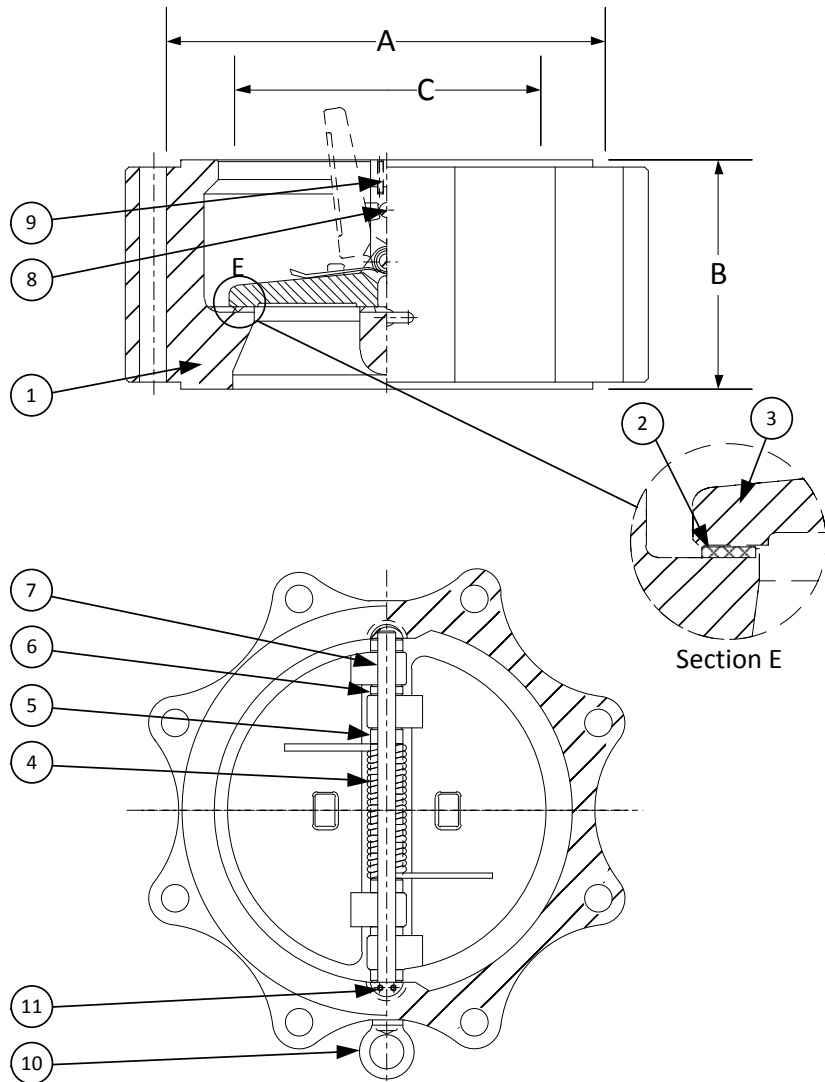

PARTS LIST

ITEM	DESCRIPTION	MATERIAL
1	BODY	CARBON STEEL (ASTM A 216, GRADE WCB)
2	SEAT*	BUNA-N O-RING
3	DISC	STAINLESS STEEL (ASTM A 351, GRADE CF8M)
4	SPRING	INCONEL X-750
5	SPRING PLATE	STAINLESS STEEL (ASTM A 182, GRADE F-316)
6	THRUST WASHER	STAINLESS STEEL (ASTM A 182, GRADE F-316)
7	HINGE PIN	STAINLESS STEEL (ASTM A 182, GRADE F-316)
8	STOP PIN	STAINLESS STEEL (ASTM A 182, GRADE F-316)
9	LOCATING PIECE	STAINLESS STEEL (ASTM A 182, GRADE F-316)
10	LIFTING LUG	CARBON STEEL
11	SCREW	STAINLESS STEEL (316)

*Optional Seat Materials Available in Viton, EPDM, PTFE, and Neoprene.

PRODUCT NUMBER†	SIZE	DIMENSIONS			WEIGHT
		A	B	C*	
2DL2R-CS-3611X	2	4-1/8	2-3/8	1-15/16	18
21/2DL2R-CS-3611X	2-1/2	4-7/8	2-5/8	2-11/32	22
3DL2R-CS-3611X	3	5-3/8	2-7/8	2-29/32	30
4DL2R-CS-3611X	4	6-7/8	2-7/8	3-53/64	44
5DL2R-CS-3611X	5	7-3/4	3-3/8	4-13/16	51
6DL2R-CS-3611X	6	8-3/4	3-7/8	5-49/64	84
8DL2R-CS-3611X	8	11	5	7-1/2	91
10DL2R-CS-3611X	10	13-3/8	5-3/4	9-7/16	156
12DL2R-CS-3611X	12	16-1/8	7-1/8	11-1/4	252
14DL2R-CS-3611X	14	17-3/4	7-1/4	12-5/8	291
16DL2R-CS-3611X	16	20-1/4	7-1/2	14-11/16	464
18DL2R-CS-3611X	18	21-5/8	8	16-9/16	431
20DL2R-CS-3611X	20	23-7/8	8-5/8	18-7/16	501
24DL2R-CS-3611X	24	28-1/4	8-3/4	21-5/8	682
30DL2R-CS-3611X	30	34-3/4	12	28-7/16	1321
36DL2R-CS-3611X	36	41-1/4	14-1/2	34-3/8	1898
42DL2R-CS-3611X	42	48	17	40-9/16	3236
48DL2R-CS-3611X	48	54-1/2	20-5/8	44-3/16	4899

*Minimum companion flange bore.

Available with thru-hole bolting or threaded bolt holes.

†See "Style DL Product Number Configuration" for additional options.

BODY PRESSURE & TEMPERATURE RATINGS – NON SHOCK		
NOM. RATING	MEDIA	2" to 48"
150# (WAFFER LUG)	W.O.G.	285 PSI @ 100°F

APPLICABLE STANDARDS

• Design ASME B16.5, B16.34	• MSS SP – 6
• Conform to API 594 & 6D	• MSS SP – 25
• Testing API 598	• MSS SP – 55

KECKLEY

3400 CLEVELAND SKOKIE ILLINOIS

DRAWING NO.
AL 102040

DIMENSIONAL ASSEMBLY

150# Retainerless Wafer Lug Body

Double Disc Check Valve

MAT'L: Cast Carbon Steel

REQ. ---

PART NO.
DL2R-CS-3611X

SCALE: NTS

DATE: 07/01/2011

DR. BY DSF