

"Apollo"[®] INTERNATIONAL

SUBMITTAL SHEET

COMING SOON! **LEAD FREE**

Model 711F

Class 125 Outside Screw & Yoke **Globe Valve**



Job Name:	
Job Location:	
Engineer:	
Contractor:	
Tag:	
PO Number:	
Representative:	
Wholesale Distributor:	

DESCRIPTION

The **Apollo International™** Model 711F Flanged Cast Iron Globe valve provides efficient throttling capabilities. The Model 711F Globe valve can reliably be installed in most plumbing and heating systems (or building service piping).

FEATURES

- Compatible with ANSI 125# & 150# Flanges
- Full Port
- Bronze Mounted Seat Rings
- Positive Shut-off
- Throttling Capabilities
- Adjustable Graphite Stem Packing
- Outside Screw & Yoke
- Flanged Connection
- Bolted Bonnet
- Rugged Iron Hand Wheel
- Back Seat Protection

STANDARDS

- MSS SP-85, "Gray Iron Globe & Angle Valves Flanged and Threaded Ends"
- ASME B16.10, "Face-to-Face and End-to-End Dimensions of Valves"

PERFORMANCE RATING

- Saturated Steam: 125 psi (8.6 Bar) to 353°F(178°C)
- Cold Working Pressure: 200 psi (13.8 Bar) at 100°F
- Temperature Range: -20°F to 406°F

STANDARD MATERIALS LIST

	Part Name	Material
1	Body	Cast Iron (ASTM A126 CL B)
2	Guide Spindle	Brass (ASTM B16)
3	Seat Ring	Cast Bronze (ASTM B62)
4	Disc Seal Ring	Cast Bronze (ASTM B62)
5	Disc	Cast Iron (ASTM A126 CL B)
6	Swivel Nut	Cast Brass (ASTM B584)
7	Stem	Brass (ASTM B16)
8	Bolts	Carbon Steel (ASTM A307 B)
9	Gland Follower Bolts	Carbon Steel (ASTM A307 B)
10	Body Gasket	Graphite
11	Bonnet	Cast Iron (ASTM A126 CL B)
12	Packing	Graphite
13	Packing Gland	Cast Brass (ASTM B584)
14	Gland Follower	Ductile Iron (ASTM A536 65-45-12)
15	Gland Follower Nut	Carbon Steel (ASTM A307 B)
16	Yoke Bushing	Cast Bronze (ASTM B62)
17	Screw	Carbon Steel (ASTM A307 B)
18	Handwheel	Cast Iron (ASTM A126 CL B)
19	Identification Plate	Aluminum
20	Washer	Carbon Steel (ASTM A307 B)
21	Handwheel Nut	Ductile Iron (ASTM A536 65-45-12)

ORDER INFORMATION

Size (in.)	Part Number
2"	6GB118B1
2-1/2"	6GB119B1
3"	6GB110B1
4"	6GB11AB1
5"	6GB11BB1
6"	6GB11CB1
8"	6GB11EB1
10"	6GB11GB1

Apollo Valves / **Conbraco Industries, Inc.**
701 Matthews Mint-Hill Road, Matthews, NC 28105 USA
www.apollovalves.com | (704) 841-6000

This specification is provided for reference only. Conbraco Industries Inc. reserves the right to change any portion of this specification without notice and without incurring obligation to make such changes to Conbraco products previously or subsequently sold. Please visit our website @ www.apollovalves.com for the most current information.



"Apollo"[®] INTERNATIONAL

SUBMITTAL SHEET

COMING SOON! **LEAD FREE**

Model 711F

Class 125 Outside Screw & Yoke **Globe Valve**

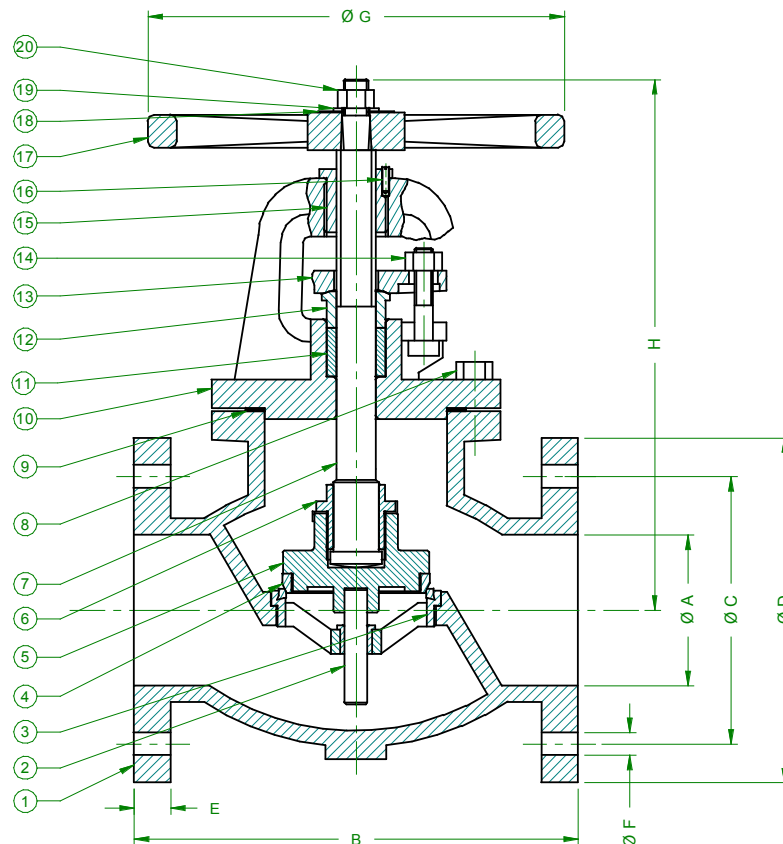

Size (in.)	Dimensions (in.)								Wt. (lbs.)	Cv (Typ)
	A	B	C	D	E	F	G	H (Open)		
2"	2.00	8.00	4.76	6.00	0.62	0.75	7.00	11.61	36	52
2.5"	2.50	8.50	5.50	7.00	0.69	0.75	7.00	12.99	49	76
3"	3.00	9.50	6.00	7.50	0.75	0.75	8.00	14.37	64	116
4"	4.00	11.50	7.50	9.00	0.94	0.75	10.00	15.75	94	204
5"	5.00	13.00	8.50	10.00	0.94	0.88	12.00	17.72	137	328
6"	6.00	14.00	9.50	11.00	1.00	0.88	12.00	20.67	195	488
8"	8.00	19.50	11.75	13.50	1.12	0.88	14.00	23.43	315	874
10"	10.00	24.50	14.25	16.00	1.19	1.00	16.00	26.97	485	1376

Cv = GPM @1 psi pressure drop, 60°F water

*Cv values are estimates only

Apollo Valves / **Conbraco Industries, Inc.**
701 Matthews Mint-Hill Road, Matthews, NC 28105 USA
www.apollovalves.com | (704) 841-6000

This specification is provided for reference only. Conbraco Industries Inc. reserves the right to change any portion of this specification without notice and without incurring obligation to make such changes to Conbraco products previously or subsequently sold. Please visit our website @ www.apollovalves.com for the most current information.

